

HYDAC INTERNATIONAL

Filter Systems

Fluid Condition Monitoring & Control

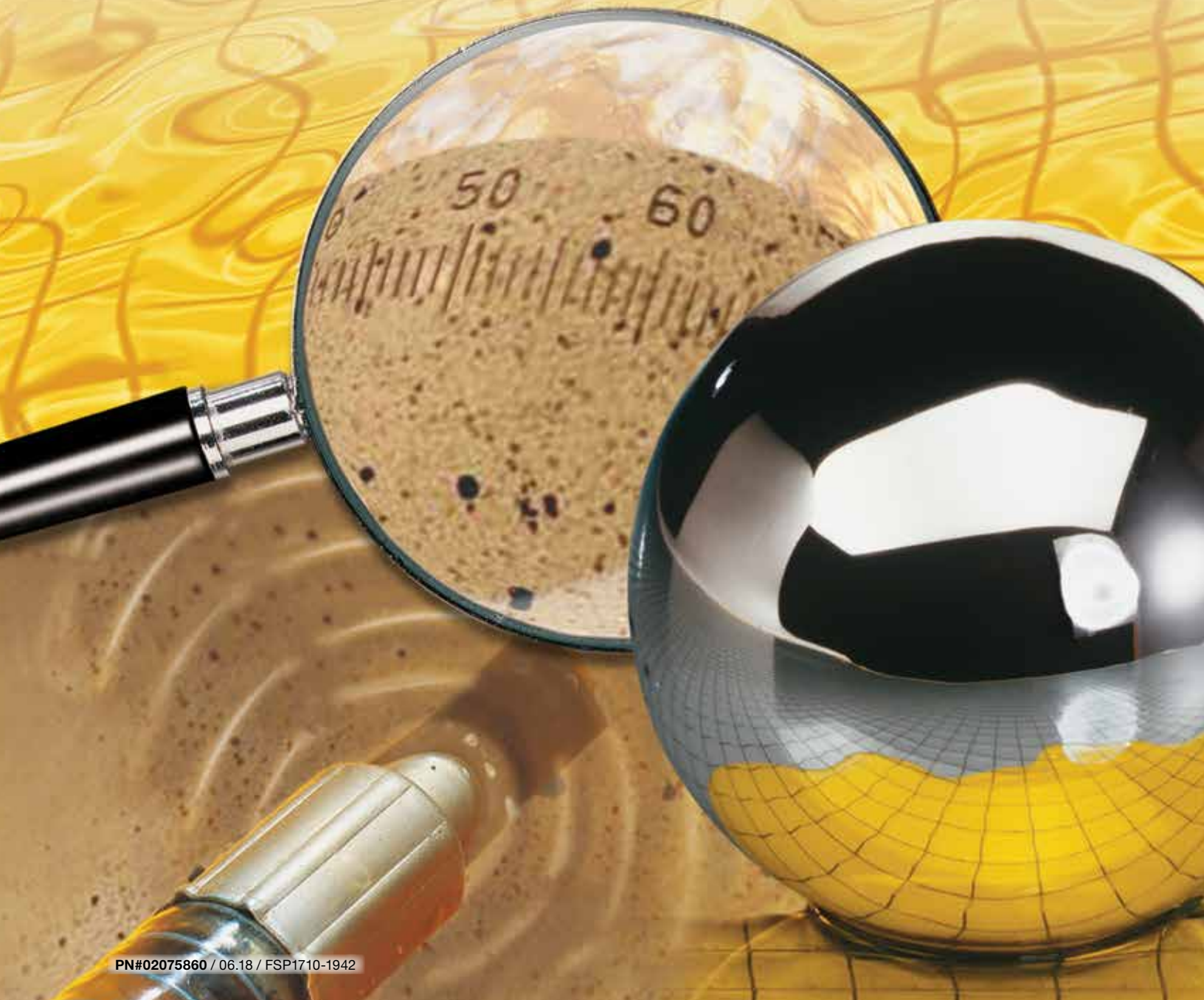



Components, Systems and Service. All from one Company.

Our fluid engineering solutions are defined by the scope and complexity of our customers' requirements.

Our products range from individually designed components in the fields of fluid engineering, hydraulics and electronics right up to complete systems for specific functions.

All components and systems are conceived and designed in-house. Experienced industrial and product specialists develop innovative products and efficient solutions for high-quality, cost-effective production. Throughout the globe, our production facilities share one common goal: quality. We take great pride in both our products and solutions.

Industries and Applications

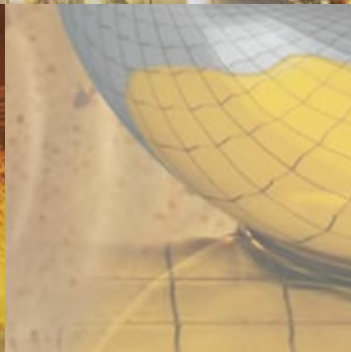
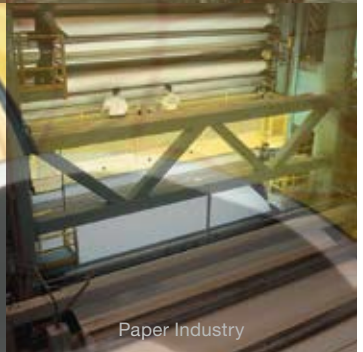
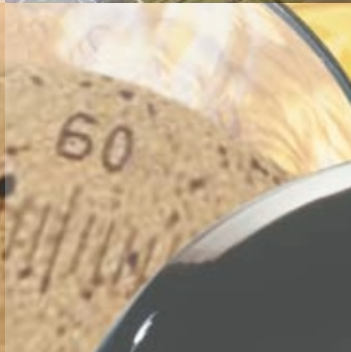
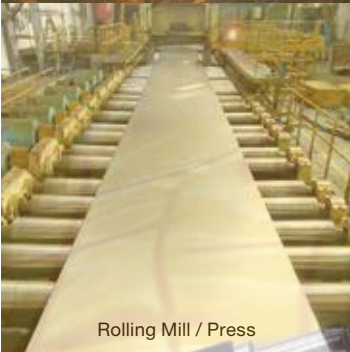
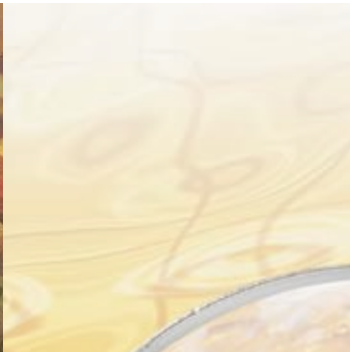

Overview Introduction - A2 , Cost Savings Calculations - A3 , ISO Cleanliness Levels - A4	A
Contamination Monitors CS 1000 - B2 ; CSI-C-11 - B6 ; HY-Trax – Manual - B12 ; HY-Trax – Telematics - B14 ; CS 2000 - B18 ; CSM 1000 - B20 ; CSM 2000 - B22 ; FCU 1000 - B24 ; FCU 2000 - B26 ; RBSA - B30 ; MCS - B32 ; AS 1000 - B34 ; AS 3000 - B36 ; SMU 1200 - B38 ; FMS - B40 ; CTU 1000 - B42 ; CTM-SC - B44 ; CTM-EB - B46 ; MM - B52 ; FAS - B53 ; FASH - B54	B
Diagnostics - C1 HMG 2500 - C2 ; HMG 4000 - C6	C
Offline Filtration Systems RFSA - D2 ; OF7-BC - D4 ; HFS-15 - D6 ; OFCD-BC - D10 ; OFCS & OFCD - D12 ; OFCD-MV - D14 ; OFCD-HV - D16 ; OFS - D18 ; OFS-AM - D20 ; OF5HS / OF5HD - D22 ; MCO - D24 ; OF5HD-HV Framed - D26 ; OFAS / OFAD - D28 ; LSN - D30 ; OFX - D32 ; OLF Compact - D36 ; OLF - D40 ; OLFP 1/3/6 - D44 ; NxTM TriMicron Element - D48 ; MAFH-A - D50 ; MAFH-E - D52 ; FAM5 - D54 ; FAMH - D58 ; HTB - D62	D
Replacement Elements Pressure Elements - E2 Dimicron® Elements, Cartridge Elements, Spin-on Elements, Aquamicon® Elements, Betamicron®/Aquamicon® Elements, Betterfit® Interchange Elements - E4	E
Reference Materials Viscosity Charts - F2	F



Filter System Division
580 West Park Road
Leetsdale, PA 15056
+1.724.318.1100
Internet: www.hydac-na.com
Email: FSP.catalog@hydac-na.com

NOTE

Information and related materials are subject to change without notice. This catalog, and all information and related materials it contains, are provided “as is.” HYDAC makes no representation or warranty whatsoever regarding the completeness, accuracy, “up-to-dateness”, or adequacy of, the HYDAC-NA domain and this catalog.

OVERVIEW

Introduction

Contamination and degraded fluid quality cause inefficient operation, component wear, and eventually failures in all hydraulic and lubrication systems. The products in this catalog are the tools that are needed to prevent such occurrences. HYDAC recommends a three step approach to controlling contamination in any system:

Assess

Start by gathering complete information on the system. This includes:

- a list of the most critical components
- the manufacturer's recommended ISO class for each component
- the type of oil being used
- flow rate & operating pressure
- fluid temperature & ambient temperature
- system's operational characteristics
- details on all current filters in the system
- solid contamination levels (ISO class)
- water content levels
- details on all current filters in the system

Recommend & Implement

Next, specify your recommendations for upgrading the current filtration, and adding the appropriate supplementary filtration:

- pressure filters
- return line filters
- manifold cartridge/circuit protector filters
- element micron rating
- reservoir breathers or filler breathers
- strainer baskets
- addition of offline filtration loop
- use of portable filters for filling/temporary offline loops
- sufficient water removal protection
- proper fluid monitoring devices

Monitor & Maintain

Finally, use reliable methods for continuous monitoring of the fluid conditions including:

- solid contamination
- water content
- additive depletion
- element clogging
- periodic detailed analysis of actual fluid samples
- portable filters for correcting unacceptable levels



An OLCFM-15 on a plastic injection machine.



An OLF-60 on a test stand.



OFS Filtration Station with HPU.



OLF Compact on a mining truck.

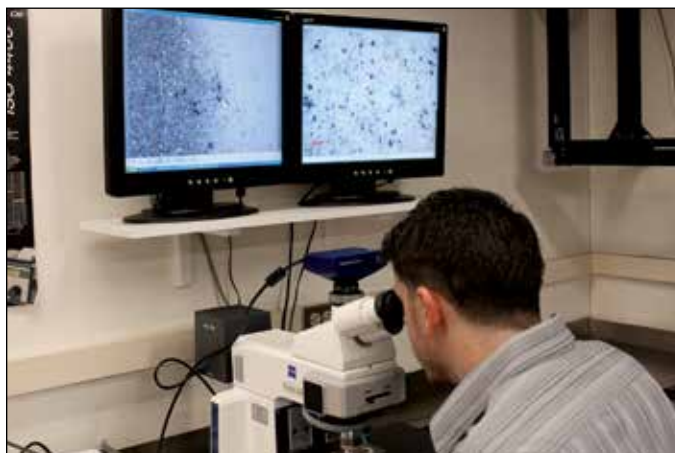

Microscope with camera attached to a monitor

Savings Realized by Proper Contamination Control

The money invested in contamination control can easily be justified when the resulting machine availability increases significantly. The graph below illustrates that there is a range in which this investment really pays off.

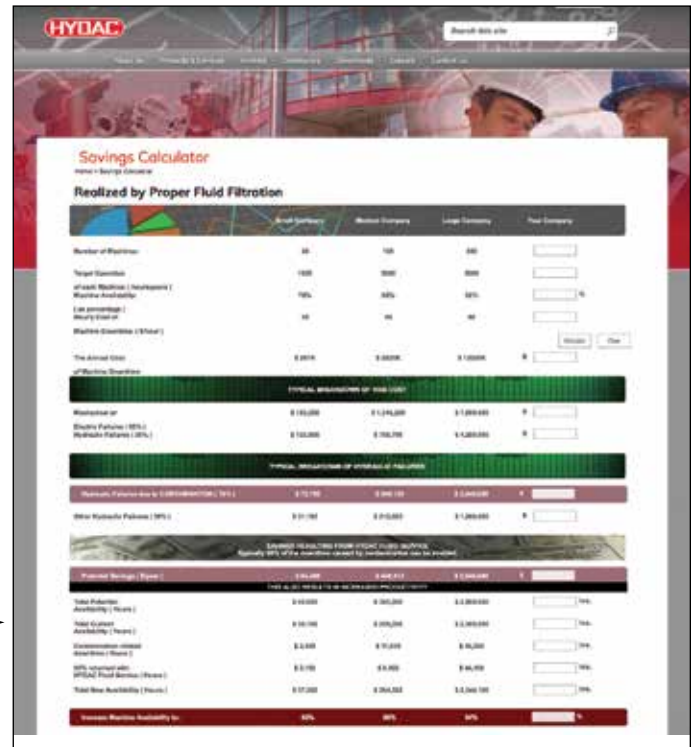
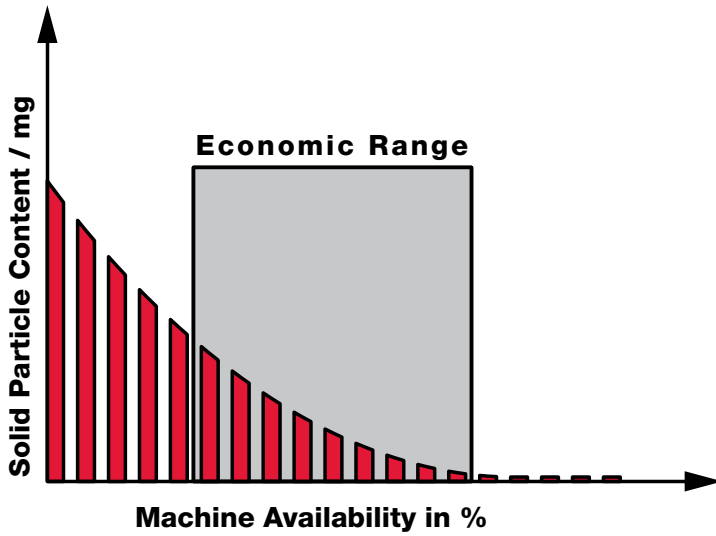

Try our automated savings calculator at:

www.HYDACusa.com

Savings Calculation Example

This example demonstrates how to calculate the potential savings that will be realized by implementing a proper fluid service program.

	Example	Your Data
Number of Machines	50	a _____
Operating Hours per year	5,000	b _____
Current Availability	92%	c _____
Downtime Costs per hour	\$60	d _____
Total Downtime Costs	\$1,200,000	e _____ $(a \times b \times \frac{100 - c}{100} \times d)$
Downtime costs due to:		
- mechanical/electrical failures (65%)	\$780,000	f _____ $(e \times .65)$
- hydraulic failures (35%) of which:	\$420,000	g _____ $(e \times .35)$
- 70% is due to the fluid	\$294,000	h _____ $(g \times .70)$
- 30% is caused by other faults	\$126,000	i _____ $(g \times .30)$
HYDAC Fluid Service can return 90% of the fluid related downtime costs	\$264,600	j _____ $(h \times .90)$

OVERVIEW

ISO 4406 Code

Cleanliness levels are defined by three numbers divided by slashes (/). These numbers correspond to 4, 6, and 14 micron, in that order. Each number refers to an ISO Range Code, which is determined by the number of particles for that size (4, 6, & 14µm) and larger present in 1 ml of fluid. Each range is double the range below. Refer to the chart below to see the actual ranges.

Example:

larger than 4µm = 22,340

larger than 6µm = 1,950

larger than 14µm = 43

ISO Code = 22 / 18 / 13

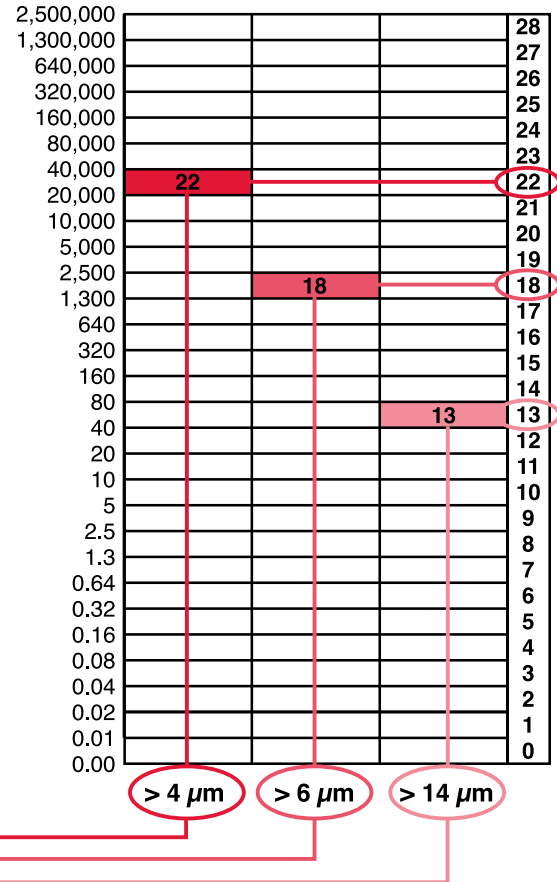

Achieving the appropriate cleanliness level in a system

The only way to achieve and maintain the appropriate cleanliness level in a hydraulic or lubrication system is to implement a comprehensive filtration program. HYDAC offers all of the products needed to develop a comprehensive filtration program, including:

Solid Contamination

- Pressure filters
- Return line filters
- Offline filtration loops
- Oil transfer units for precleaning of new oil
- Portable and online contamination monitors
- Reservoir breathers and filler/breathers

Water Content

- Water content sensors
- Reservoir breathers with silica gel desiccant
- Vacuum dehydration water removal units
- Water removal elements

Fluid Analysis

- Bottle sampling kits
- Complete analysis kits

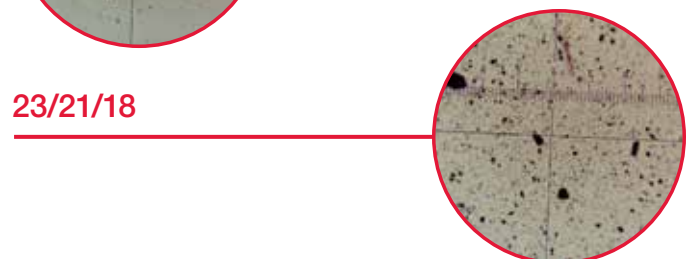
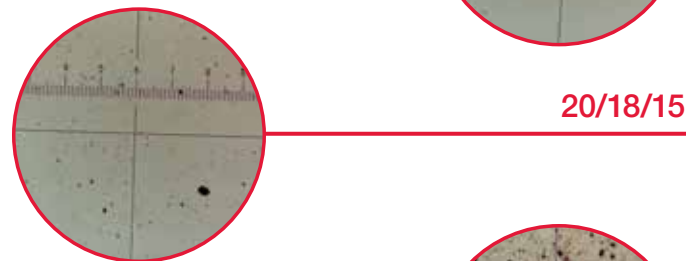
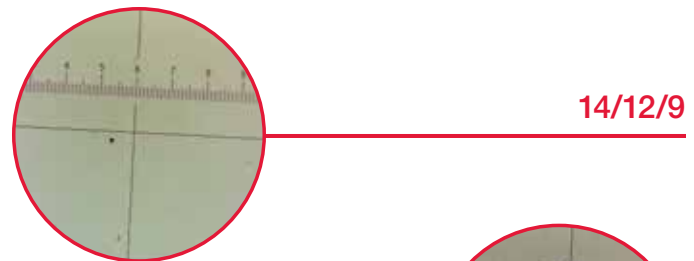

Finding the cleanliness level required by a system

1. Starting at the left hand column, select the most sensitive component used in the system.
2. Move to the right to the column that describes the system pressure and conditions.
3. Here you will find the recommended ISO class level, and recommended element micron rating.

	Low/Medium Pressure Under 2000 psi (moderate conditions)		High Pressure 2000 to 2999 psi (low/medium with severe conditions ¹)		Very High Pressure 3000 psi and over (high pressure with severe conditions ¹)	
	ISO Target Levels	Micron Ratings	ISO Target Levels	Micron Ratings	ISO Target Levels	Micron Ratings
Pumps						
Fixed Gear or Fixed Vane	20/18/15	20	19/17/14	10	18/16/13	5
Fixed Piston	19/17/14	10	18/16/13	5	17/15/12	3
Variable Vane	18/16/13	5	17/15/12	3	not applicable	not applicable
Variable Piston	18/16/13	5	17/15/12	3	16/14/11	3 ²
Valves						
Check Valve	20/18/15	20	20/18/15	20	19/17/14	10
Directional (solenoid)	20/18/15	20	19/17/14	10	18/16/13	5
Standard Flow Control	20/18/15	20	19/17/14	10	18/16/13	5
Cartridge Valve	19/17/14	10	18/16/13	5	17/15/12	3
Proportional Valve	17/15/12	3	17/15/12	3	16/14/11	3 ²
Servo Valve	16/14/11	3 ²	16/14/11	3 ²	15/13/10	3 ²
Actuators						
Cylinders, Vane Motors, Gear Motors	20/18/15	20	19/17/14	10	18/16/13	5
Piston Motors, Swash Plate Motors	19/17/14	10	18/16/13	5	17/15/12	3
Hydrostatic Drives	16/15/12	3	16/14/11	3 ²	15/13/10	3 ²
Test Stands	15/13/10	3 ²	15/13/10	3 ²	15/13/10	3 ²
Bearings						
Journal Bearings	17/15/12	3	not applicable	not applicable	not applicable	not applicable
Industrial Gearboxes	17/15/12	3	not applicable	not applicable	not applicable	not applicable
Ball Bearings	15/13/10	3 ²	not applicable	not applicable	not applicable	not applicable
Roller Bearings	16/14/11	3 ²	not applicable	not applicable	not applicable	not applicable

1. Severe conditions may include high flow surges, pressure spikes, frequent cold starts, extremely heavy duty use, or the presence of water
2. Two or more system filters of the recommended rating may be required to achieve and maintain the desired Target Cleanliness Level.

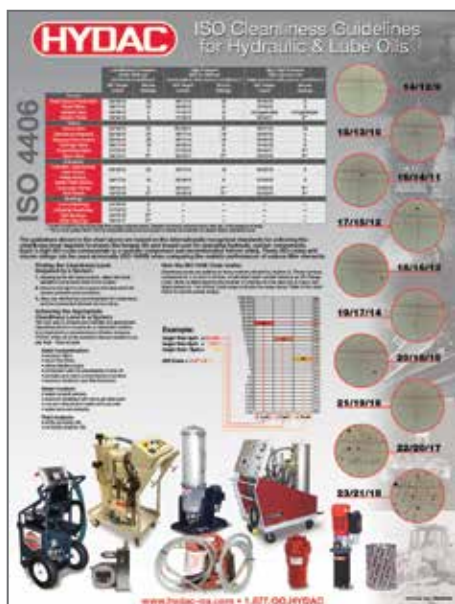

FREE Poster!

The information on these two pages is also available on our **ISO Cleanliness Guidelines** poster. Visit our web site to request your FREE copy.

www.hydac-na.com/sites/hydac-na
Click on the link (bottom right): Free ISO Poster

OVERVIEW

Notes

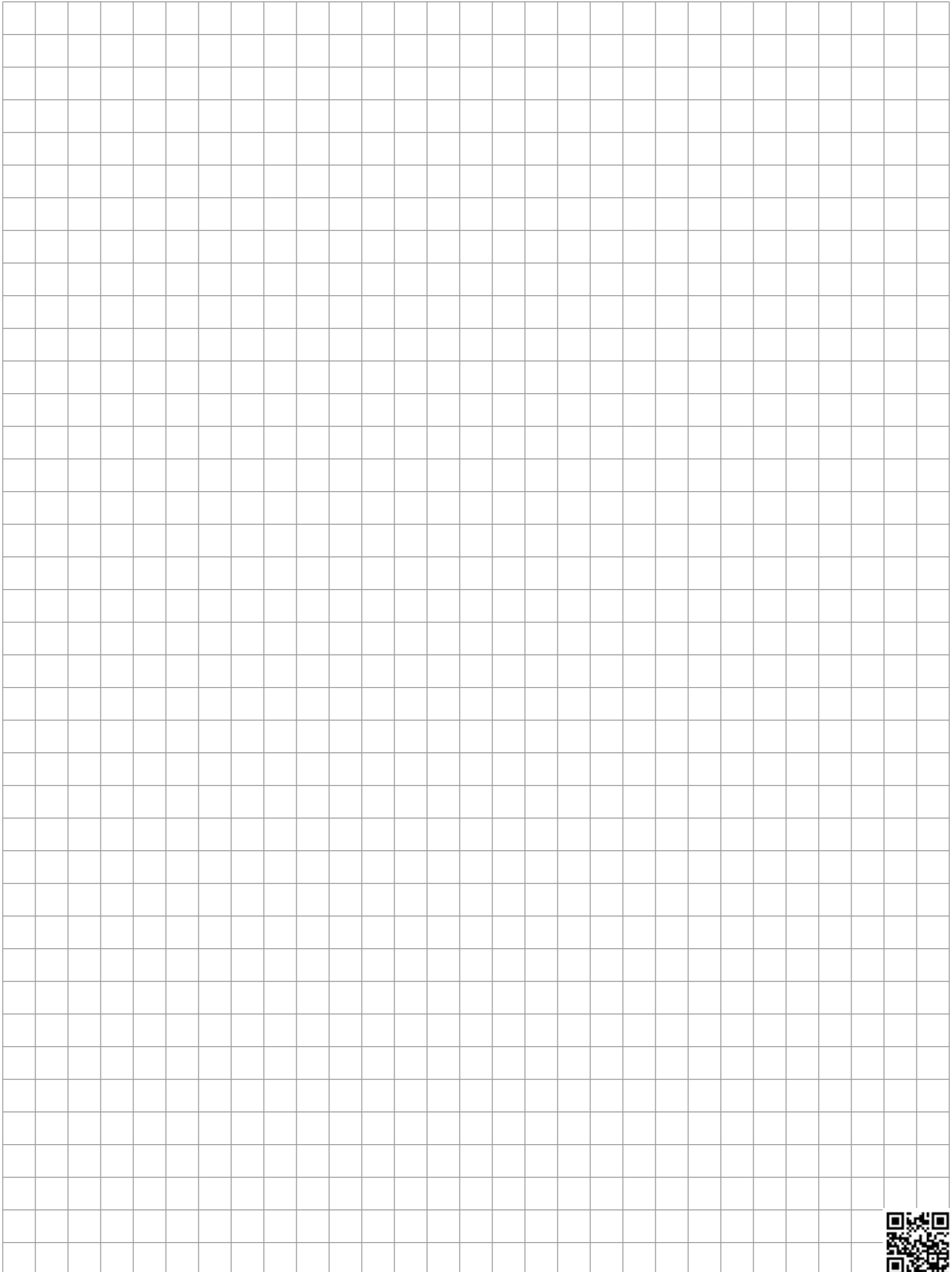

B Contamination Management

Contamination management pertains to the analysis and optimization of processes with regard to the cleanliness of components, systems and the purity of the fluids used. Our fluid condition monitoring products include both in-line and offline sensors to measure contamination and/or water saturation levels of the hydraulic system. By implementing fluid condition monitoring equipment in conjunction with the appropriate filtration equipment, a major portion of particulate contamination introduced during manufacturing and assembly can be effectively and efficiently removed. The result is cost savings by virtue of smaller performance deviations on test stands caused by the sudden clogging of particles in sensitive system components, as well as lower costs associated with warranty and non-warranty courtesy work.

CONTAMINATION MONITORS

CS 1000 Series

Contamination Sensor



CS 1000 with Block Kit

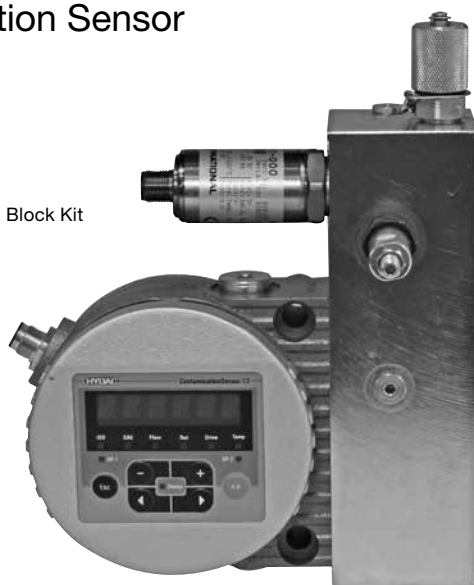

CS 1000 without display

CS 1000 with display

Description

The CS 1000 Contamination Sensor is the latest HYDAC development for continuous measurement of solid contamination of fluids.

Using the latest technology and materials, the CS 1000 is a reliable measuring instrument that is permanently mounted on your mobile or industrial equipment.

The attractive cost-to-performance ratio makes it especially interesting for OEM applications. Online, real-time condition monitoring allows you to have total predictive maintenance.

Applications

Monitoring system on vehicles such as

- Construction equipment
- Agricultural machinery
- Mobile and stationary equipment

Industrial hydraulic systems

- Integration into power unit monitoring systems
- Hydraulic test stands

Combination with filter unit

Features

- Version with or without display
- Display with pivot-function
- Display with 6-digit ISO Code (*optional*)
- Measurement of solid particle contamination in hydraulic and lubricating fluids
- Compact and rugged design
- Type of protection IP67

Technical Specifications

General data	
Self-diagnosis	Continuous with error display via status LED and display
Display (only with CS 1x2x)	LED, 6 digits, in 17 segment format
Measured variables	ISO 99 (ISO 4406:1999) SAE (SAE AS 4059) or ISO 87 (ISO4406:1987) NAS (NAS 1638)
Installation position	(Recommended: Vertical Orientation with flow south to north)
Ambient temperature range	-30 °C to +80 °C / -22 °F to 176 °F
Storage temperature range	-40 °C to +80 °C / -40 °F to 176 °F
Relative humidity	max. 95%, non-condensing
Seal material	FPM for CS1xx0 / EPDM for CS1xx1
Protection class	III (safety extra-low voltage)
IP class	IP 67 (provided it is correctly connected)
Weight	2.9 lb (1.3 kg)
Hydraulic data	
Measuring range	Sensor measures from Class ISO 9/8/7 (MIN) to Class ISO 25/24/23 (MAX) Calibrated in the range ISO 13/11/10 to 23/21/18
Accuracy	+/- ½ ISO class in the calibrated range
Operating pressure	max. 5075 psi / 250 bar
Hydraulic connection	Inline or hose connection (A,B): thread G1/4, ISO 228 or flange connection (C,D): DN 4
Permitted measurement flow rate	30 to 500 ml/min
Permitted viscosity range	32 to 4635 SUS(1 to 1000 mm2/s)
Fluid temperature range	0 to +85°C, +32 to +185°F
Electrical data	
Connection, male	M12x1, 8-pole, to DIN VDE 0627 or IEC61984
Supply voltage	9 to 36 VDC, residual ripple < 10%
Power consumption	3 watts max.
Analogue output (2 conductor technique)	4 to 20 mA output (active): Max. ohmic resistance 330Ω or 2 to 10 V output (active): Min. load resistance 820Ω Calibration ± 1 % FS
Switch output	passive, n-switching Power MOSFET: max. current 1.5 A; normally open
RS485 interface	2-wire, half duplex to transfer the HSI protocol in conjunction with a PC
HSI (HYDAC Sensor Interface)	1 wire, half duplex

We do not guarantee the accuracy or completeness of this information. The information is based on average working condition. For exceptional operating conditions please contact our technical department. All details are subject to technical changes.

Model Code

CS 1 2 2 0 - A - 0 - 0 - 0 - 0 / - 000

Series	CS = Contamination Sensor
Resolution	1 = 4 Particle Size Channels
Indicator Code	2 = ISO 4406 : 1999; SAE AS 4059 (D) >4 µm(c) >6 µm(c) >14 µm(c) >21 µm(c)
	3 = ISO 4406 : 1987; NAS 1638 >2 µm >5 µm >15 µm >25 µm ISO 4406 : 1999; SAE AS 4059 (D) >4 µm(c) >6 µm(c) >14 µm(c) >21 µm(c)
Options	1 = without Display 2 = with Display (270° rotation of display)
Fluids	0 = Hydraulic/Mineral oil 1 = Phosphate Esters
Analog Interfaces	A = 4 to 20 mA B = 2 to 10 V
Switching Output	0 = Limit Switching Output
Digital Interfaces	0 = RS485
Electrical Connection	0 = Plug M12x1, 8-pole (connection cable not included)
Mounting	0 = Inline version 1 = Flanged version
Modification Number	000 = standard K = CS Block Kit without AS1000 Sensor (requires Mounting Option 1) KAS = CS Block Kit with AS1000 Sensor (requires Mounting Option 1) KASD = CS Block Kit with AS3008 Sensor (requires Mounting Option 1)

Scope Of Delivery

- Contamination sensor
- Operation and Instruction manual
- Calibration Certificate
- CD with FluMoS Light software and manuals

Accessories

- **CSI-C-11 Sensor Interface: Part Number 4066011** (for WLAN or LAN Communication)
- Connection cable 6.5 ft. (2 m) with M12x1 connector, screened 8-pole: Part Number 03281220
- Connection cable 16.4 ft. (5 m) with M12x1 connector, screened 8-pole: Part Number 02702459
- Connection cable 9.8 ft. (3 m) with M12x1 connector, 8-pole: Part Number 02091414
- CSI-D-5 Contamination Sensor Interface: Part Number 03249563
- Power Supply-CS1XXX-PS1: Part Number 03376530

Model Codes containing RED are non-standard items – Minimum quantities and longer lead times may apply - Contact HYDAC for information and availability

CS 1000 Block Kit

Includes: CS and AS Sensor Connection Cables, 2 Test Points, 2 Microflex hoses, FluMoS Light software

The Contamination Sensor Block KIT (CS 1000 Block KIT) combines two condition monitoring products, the CS 1000 series (Contamination Sensor) and the AS 1000 series (Aqua Sensor) into one plug and play unit. It serves as an on-line measurement of solid contamination and water in hydraulic and lube systems.

Note: Flow control is necessary when utilizing the CS 1000 sensor. Flow must be maintained through the sensor module to ensure accurate readings. Utilization of the CS Block Kit is required to maintain Sensor flow rate range as described in the Technical Specifications (at the left).

Quick Order Guide

Model Code	Part Number	Description
CS1220-A-0-0-0-0 /-000	03236362	4-20mA display model
CS1210-A-0-0-0-0 /-000	03240458	4-20mA non-display model
CS1220-A-0-0-0-1 /-K	02087348	4-20mA display model and CS Block Kit without AS Sensor
CS1220-A-0-0-0-1 /-KAS	02086855	4-20mA display model and CS Block Kit with AS Sensor

CONTAMINATION MONITORS

Dimensions

CS 1000 with Block Kit

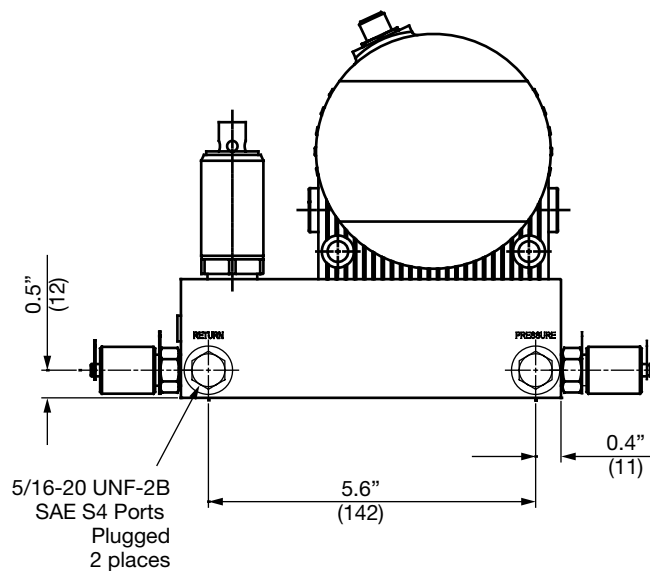
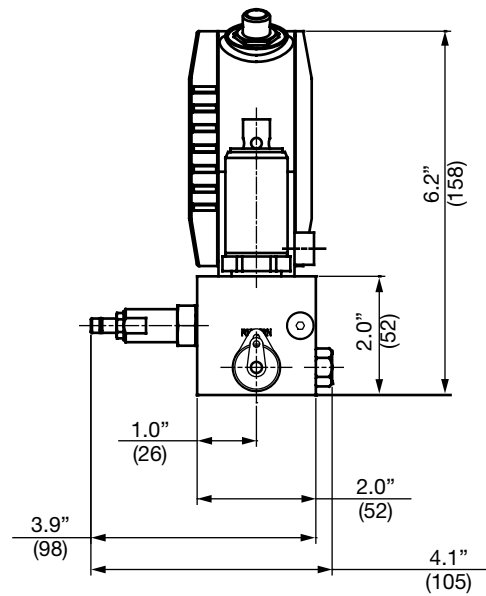
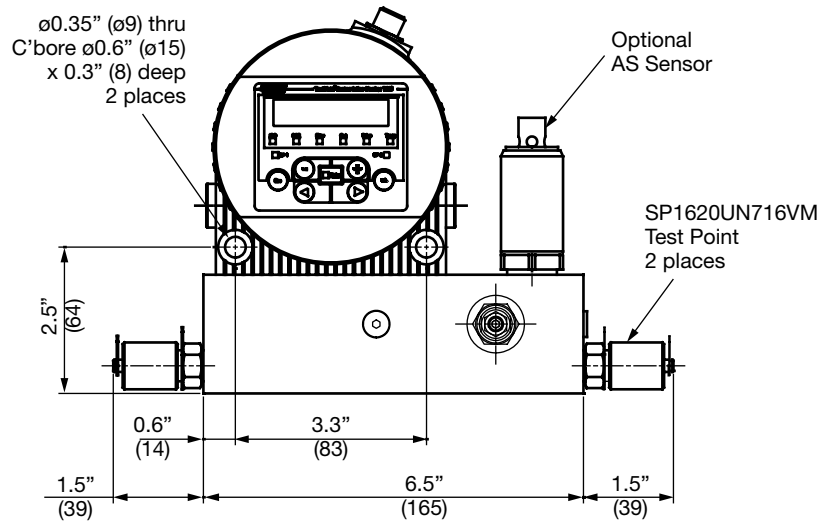

Dimensions are for general information only, all critical dimensions should be verified by requesting a certified print.

Hydraulic Connections Inline Version

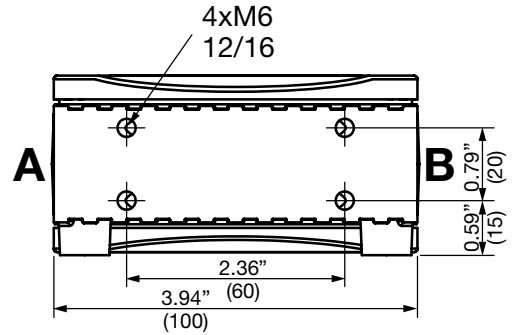
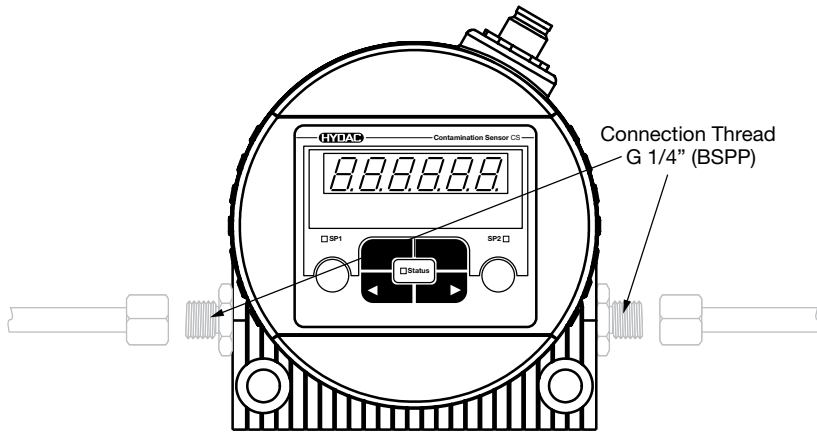

Flanged Version

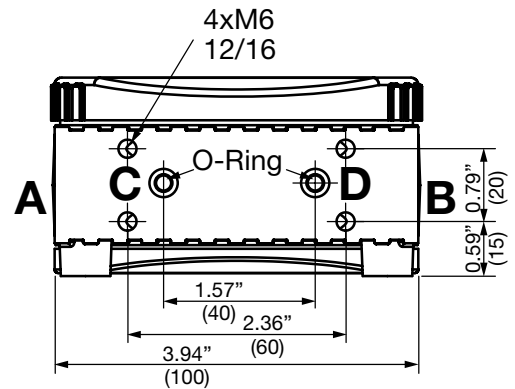
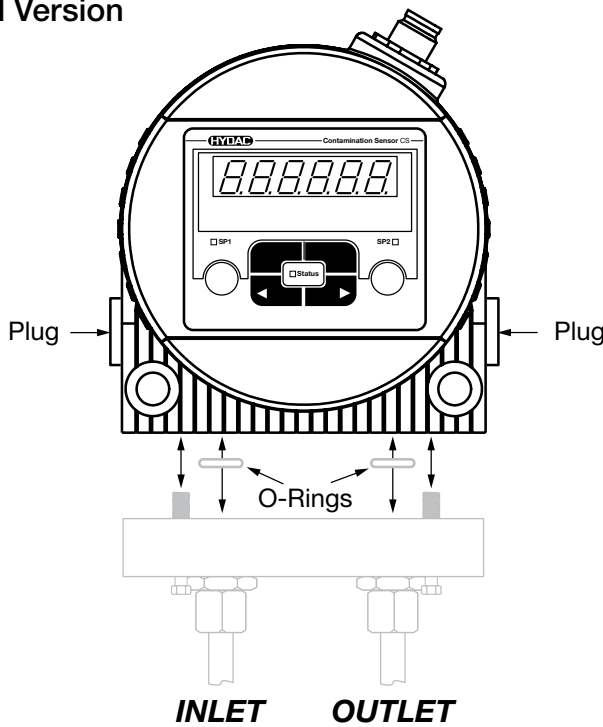

Pressure - Viscosity Range

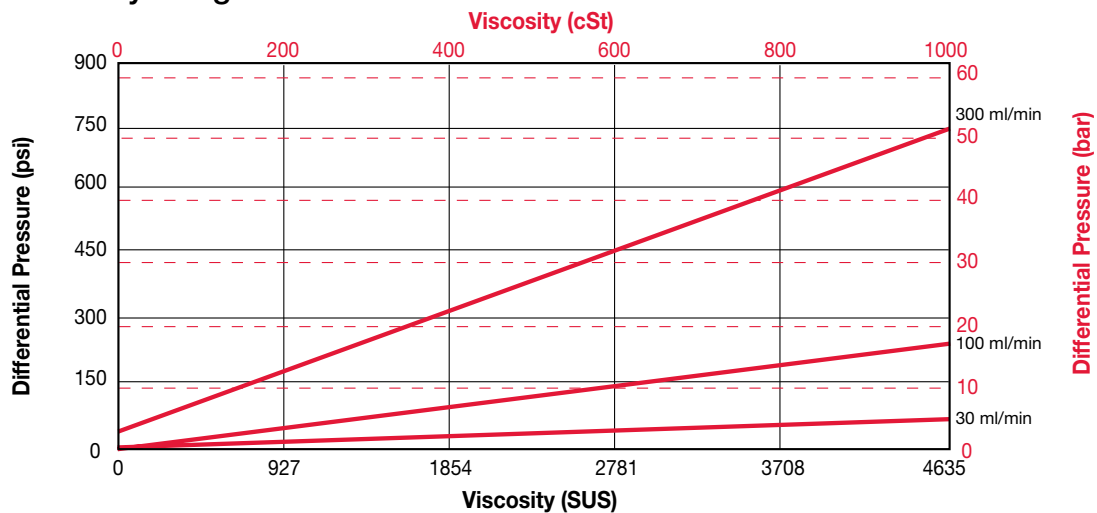

CSI-C-11 Series

ConditionSensor Interface



Description

The ConditionSensor Interface CSI-C-11 is used to transmit digital sensor signals (Hydac Sensor Interface HSI) into a network protocol (HSI TCP/IP or Modbus® TCP), which can be transmitted to a stationary (i.e. PC) or mobile device (i.e. smartphone) via network cable (LAN) or wireless connection (W-LAN). Moreover, the CSI-C-11 is equipped with an internal memory and can be used as a data logger.

At the interface module, up to two sensors can be connected via M12 connector and supplied with power. In addition, the CSI-C-11 is equipped with an Ethernet connector (M12x1 socket), which allows the integration of connected sensors into company networks or superior condition monitoring (CM) and control systems (PLC).

Applications

- Construction Equipment
- Agricultural Machinery
- Test Benches
- Industrial Hydraulic Systems
- Combination with Filter Unit
- Power Units
- Any hydraulic system that requires on-line monitoring
- Mobile and Stationary Mining Equipment

Features

- Ability to view in real-time measured contamination results via Wireless Connection or *Bluetooth*® wireless technology with the FluMoS Mobile App
- Storage of the measured data directly on the CSI-C-11
- Easily interface digital sensors into existing LAN network
- Direct connection of up to two (2) SMART sensors via M12x1 connectors
- Integral bracket allows for easy installation on existing machines
- Due to high protection class of IP66, no switch cabinet for installation is required
- Usable with FluMoS Mobile App

Technical Specifications

Input data	
HSI interface	HYDAC Sensor Interface for digital coupling of sensors
Output data	
Ethernet 10 Base-T / 100 Base-TX W-LAN (HSI only) 2,4 GHz, IEEE 802.11 b/g/n	Protocol: – HSI TCP/IP (Port 49322) – Modbus® TCP (Port 502)
Ambient conditions	
Operating temp. range	-13 to 185°F (-25 to 85°C)
Storage temp. range	-22 to 185°F (-30 to 85°C)
Relative humidity	0 ... 70 %, non-condensing
- marked	EN 61000-6-2, EN 61000-6-4
Protection class according to DIN 40050	IP 66
Other data	
Supply voltage	12 ... 24 V DC ± 10 %
Current requirement (module)	100 mA (plus the consumption of the connected sensors)
Sensor supply	12 ... 24 V DC (looped through)
Electrical connection	– Supply voltage: Connector, M12, 5-pole, male – SMART Sensor 1: Connector, M12, 8-pole, female – SMART Sensor 2: Connector, M12, 5-pole, female – LAN: Connector, M12, 4-pole, coding D (according to IEC61076-2-101), female – W-LAN antenna: Connector, RP-SMA socket, female
Parameterisation	via connector M12x1, 5-pole acc. to DIN VDE 0627 or W-LAN (FluMoS mobile)
Dimensions	5.2" x 3.1" x 1.4" (131 x 77.5 x 35.5 mm)
Housing	die cast aluminium
Weight	0.79 lb. (≈ 360 g)
Internal measurement data memory	
Size	64 MB
Measurement interval 60 s	> 1300 days (with CS1000 + HLB1400)
Measurement interval 60 min	> 83000 days (with CS1000 + HLB1400)

Model Code

CSI C 11 000

Type	_____	CSI
CSI =	ConditionSensor Interface	
Housing	_____	C
C =	Aluminum housing	
Output type	_____	11
11 =	HSI → Ethernet / W-LAN	
Modification	_____	000
000 =	Standard	

Accessories

Designation	Part-No.
Supply voltage	
PS5 power supply 100 – 240V AC, 50-60 Hz, 1,1 A, IP40; connector M12, 5-pole, female	3399939
ZBE47S-05 connecting cable, connector 5-pole with cable, length = 16.4 ft. (5 m)	3527626
ZBE47S-10 connecting cable, connector 5-pole with cable, length = 32.8 ft. (10 m)	3527627
Sensor connection cable for CSM-E	
ZBE43-005 connecting cable CSI-C-11, coupling / plug 8-pole, length = 1.6 ft. (0.5 m)	4193544
ZBE30-005 connecting cable CSI-C-11, coupling / plug 5-pole, length = 1.6 Ft. (0.5 m)	4193586
Network cable (LAN)	
ZBE 45-05 network cable (Patch), connector 4-pole, coding D / connector RJ45, length = 16.4 ft. (5 m)	3346100
ZBE 45-10 network cable (Patch), connector 4-pole, coding D / connector RJ45, length = 32.8 ft. (10 m)	3346101

CONTAMINATION MONITORS

Dimensions

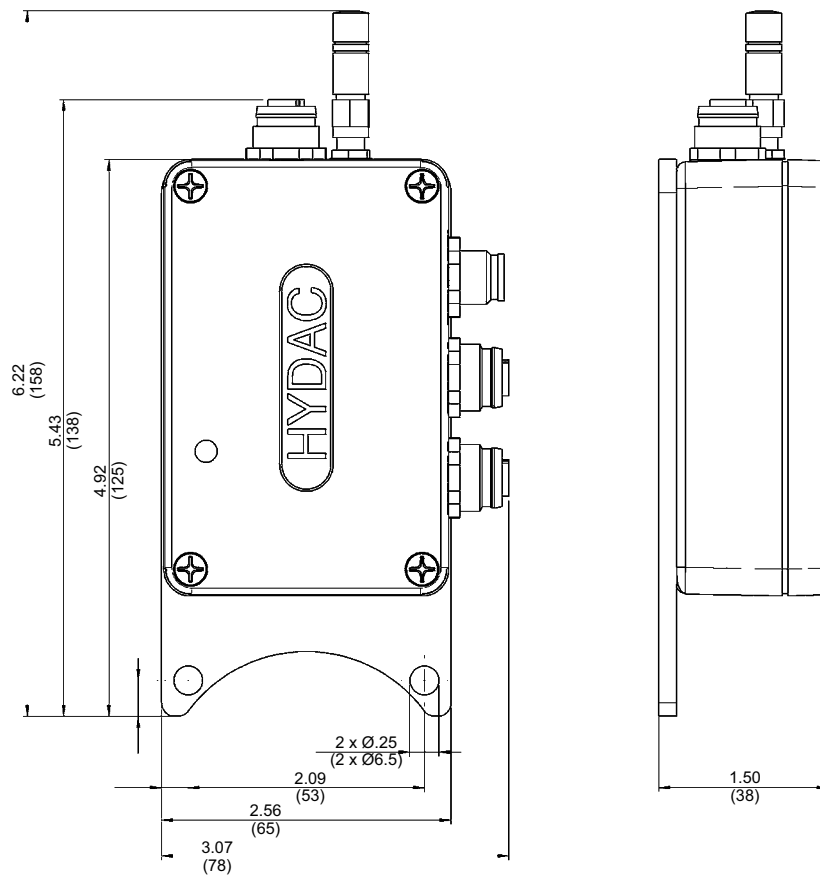

LAN

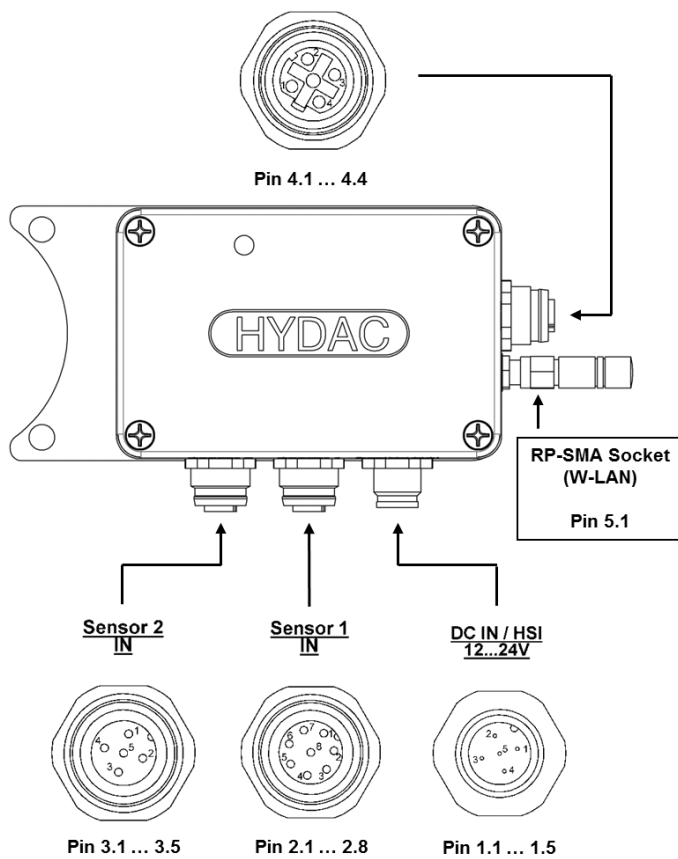

Dimensions are inches (millimeters) and for general information only, all critical dimensions should be verified by requesting a certified print.

Predictive Maintenance 4.0

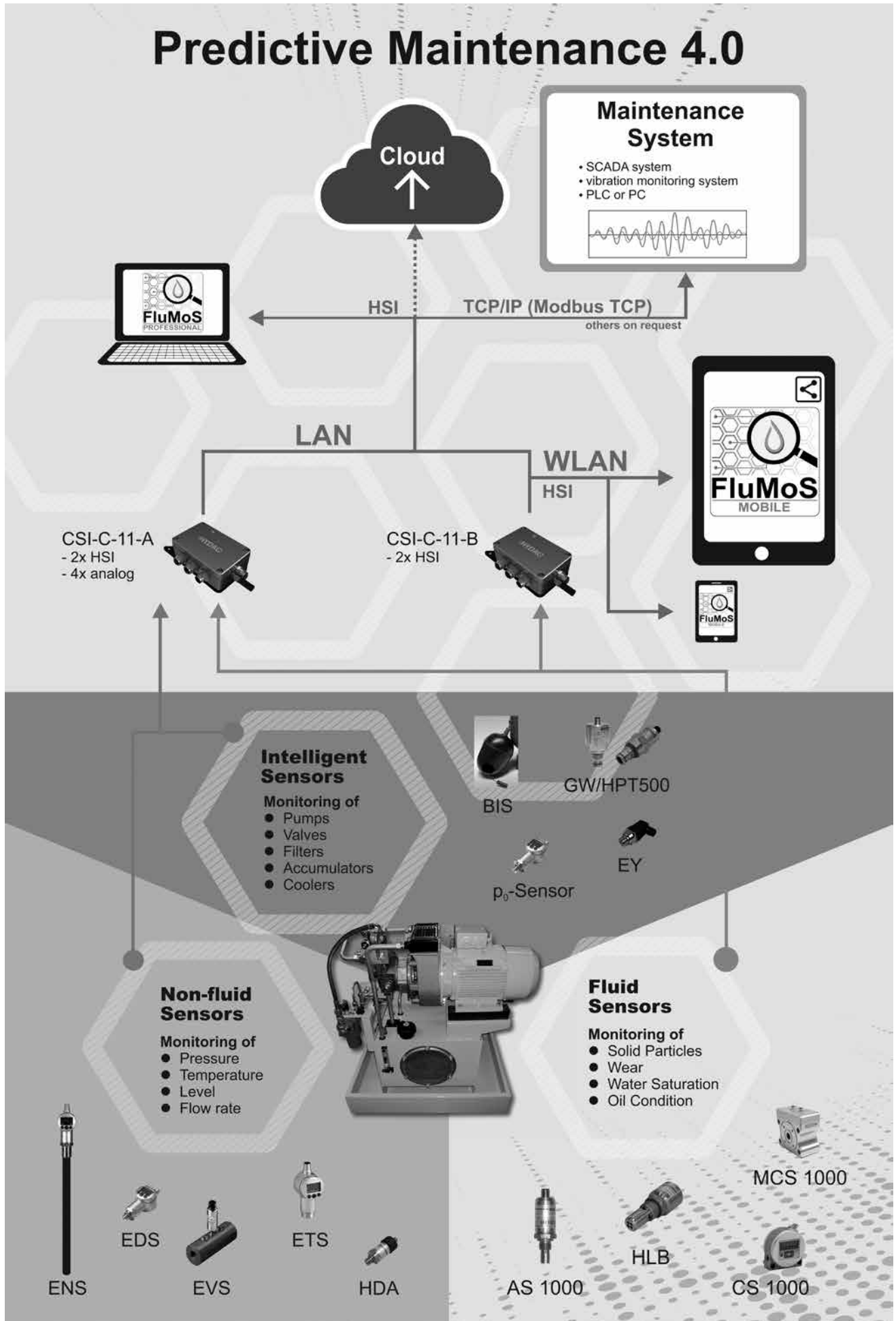

CONTAMINATION MONITORS

Plug Pin Assignment

Pin	Signal	Description	
1.1	Vin 12 ... 24 V DC	Device (CSI-C-11)	Power supply +
1.2	---	Device (CSI-C-11)	n.a.
1.3	GND	Device (CSI-C-11)	Power supply GND
1.4	---	Device (CSI-C-11)	n.a.
1.5	HIS	Device (CSI-C-11)	Parameterisation
2.1	S1 12 ... 24 V DC	Sensor 1	Power supply +
2.1	---	Sensor 1	n.a.
2.3	S1 GND	Sensor 1	Power supply GND
2.4	---	Sensor 1	n.a.
2.5	S1 HIS	Sensor 1	HSI signal
2.6	---	Sensor 1	n.a.
2.7	---	Sensor 1	n.a.
2.8	---	Sensor 1	n.a.
3.1	S2 12 ... 24 V DC	Sensor 2	Power supply +
3.2	---	Sensor 2	n.a.
3.3	S2 GND	Sensor 2	Power supply GND
3.4	---	Sensor 2	n.a.
3.5	S2 HIS	Sensor 2	HSI signal
4.1	ETH TX+	Network (LAN)	Ethernet port data transmission +
4.2	ETH RX+	Network (LAN)	Ethernet port data receive +
4.3	ETH TX-	Network (LAN)	Ethernet port data transmission -
4.4	ETH RX-	Network (LAN)	Ethernet port data receive -
5.1	ANT	Network (W-LAN)	RP-SMA-socket W-LAN-antenna

FluidMonitoring Software FluMoS

FluidMonitoring Software FluMoS light

FluMoS Light fluid monitoring software is a software package for importing, displaying and processing data from HYDAC fluid sensors. 3 sensors can be connected at the same time!

FluMoS Light can be used in conjunction with the latest generation of HSI interface sensors (CS 1000, FCU 1000, MCS 1000, AS 1000, FMM, HYDACLab®) and the sensors without HSI interface (CS 2000, FCU 2000, FCU 8000).

The FluMoS Light software is used to:

- Online display of measured values on the PC in table and graphic formats
- Storage of log files on hard disk
- Display of log files from hard disk/diskette and storage as graphic file
- Processing of stored log files with Microsoft Excel
- Remote monitoring of values measured by sensors
- Condition-based maintenance planning



FluidMonitoring Software FluMoS mobile

HYDAC FluMoS Mobile for Android – Your Access to HYDAC’s FluidControl Units

Get your fluid condition monitoring measurement data on your Android device!

FluMoS Mobile is a tool for displaying and downloading measurement data from the FluidControl Unit FCU 1310 and FCU1315 via Bluetooth connection as well as the SensorMonitoring Unit SMU 1200 to your Android device. When the CS1000, AS1008 and MCS and other smart sensors are used in conjunction with the CSI-C-11, the FluMos Mobile App can be accessed via WiFi connection to display and download measured data.

FluMoS Mobile Features (Version 1.10)

- Displays current measurement values (solid particle contamination, water saturation and temperature) of your FluidControl Unit FCU1315 in table format.
- Displays measurement value progress (solid particle contamination, water saturation and temperature) of your FluidControl Unit FCU1315 in graphic format (one graphic per measurement channel)
- Selective download of log files in .dat format from the internal memory of the FCU1315 and FCU1310 or SMU 1200 to your Android device

[possible with successor version]

- Online storage of measurement data on your Android device

You can easily forward the .dat files per e-mail to other devices such as a PC.

The files can then be processed in FluMoS.

FluidMonitoring Software FluMoS mobile - Screenshot

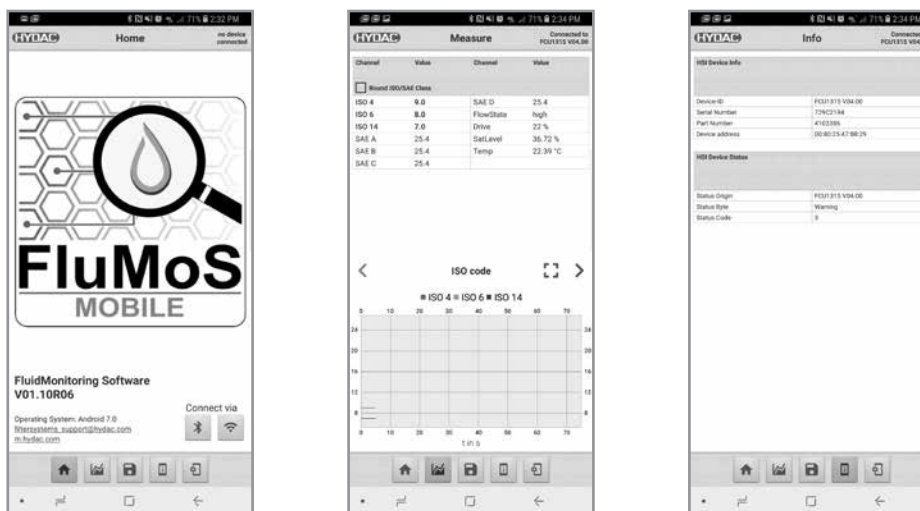

CONTAMINATION MONITORS

HY Series

HY-TRAX® – Manually Controlled Fluid Sampling System



Features and Benefits

- Provides local visibility to the fluid condition of critical systems.
- Integrated micro VSD, (Variable Speed Drive), pump/motor provides optimal flow for accurate sensor readings in variable conditions.
- The HY-TRAX® Manually Controlled Fluid Sampling System allows a user to retrieve ISO cleanliness levels from a reservoir tank or a low-pressure line (<50 psi max).
- The compact design allows for installations with tight space constraints.
- The manual rheostat VSD pump controller is housed in a compact IP 40 enclosure and allows the user to adjust the pump flow for optimal sensor readings.
- Optional AC adapter available for converting 115V AC / 60 Hz to 24V DC.
- Rugged design for field use.
- Fluorocarbon elastomer (FKM) seals.
- Fluid viscosities up to 1622 SUS (350 cSt).
- Flow control valve providing optimal pressure for accurate sensor readings.

Applications

- Mobile Equipment Technology
- Surface Mining
- Construction
- Monitoring of Oil Cleanliness in Storage Tanks
- Fleet Services
- Rail

Technical Specifications

Measuring Range	Display ISO ranges between 9/8/7 and 25/24/23 Calibration within the range ISO 13/11/10 to 23/21/18	
Contamination Output Code	Standard: ISO 4406:1999 or SAE AS 4059(D) Optional: ISO 4406:1987; NAS 1638 and ISO 4406:1999	
Self-Diagnosis	Continuously with error indication via status LED	
Pressure Rating	50 psi (3.4 bar) max	
Fluid Inlet/Outlet	SAE ORB, Size 4	
Seal Material	Fluorocarbon elastomer (FKM)	
Pump Speed	500-5000 RPM (adjustable)	
Optimal Sampling Pump Flow Rate	0.008-0.079 GPM (30-300 mL/min)	
Fluid Temp. Range	32°F to 185°F (0°C to +85°C)	
Ambient Temp. Range	-22°F to 176°F (-30°C to 80°)	
Max Viscosity	1622 SUS (350 cSt)	
Pump Type	Gear Pump	
Power Supply Voltage	24 VDC +/- 10%, Residual Ripple <10%	
Max Power/Current Consumption	100 Watt/ 4 amp	
Electric Output	4-20 mA analog output; 2-10 V analog (option for contamination monitor (CS1000)) RS485 for communication with FluMoS Software	
Electrical Specifications	4 - 20 mA analog output (<i>max burden 330 Ω</i>) 2 to 10v output (<i>min load resistor 820 Ω</i>) Limit switching output (<i>Power MOSFET</i>): max current 1.5A	
CS1000 Contamination Monitor Signal Output Connections Located on Control Enclosure	USB-B Female Port for use with Windows-based computer and FluMoS Software M12 8 pole, Male Port, Analog or Digital, for use with PLC or RS485 Communication, (4 - 20 mA is standard). 2 - 10 V is optional, must specify when ordering CS1000 Contamination Monitor	
Water Sensor (AS1008) Signal Output Connection Located on Control Enclosure:	Water sensor (AS1008) M12-5 pole Signal Output 5 pole Male Port, located on Control Enclosure	
Electrical Safety Class	III (low voltage protection)	
Enclosure Ratings	IP 40 enclosure	
Weight and Dimensions		
Communications Module Control with CS1000 Sensor	Fluid Sampling System Manifold w/ CS1000 & VSD Pump/Motor	HY-TRAX® Manual Control Module
	10 lbs. (4.5 kg)	5 lbs. (2.5 kg)
	10.3" x 6.8" x 4.3" (262 x 173 x 109 mm)	9.3" x 5.7" X 2.6" (236 X 145 x 65 mm)

Model Code

HY - 12 1 0 - - - P -

Model	_____	_____	_____	_____	_____	_____	_____	_____	_____
HY	=	HY-TRAX System							
		<i>(includes 100 micron mesh strainer and pressure gauge in manifold block)</i>							
ISO Code Preference	_____	_____	_____	_____	_____	_____	_____	_____	_____
NT	=	Manifold supplied w/o CS1xx0							
		<i>(customer will supply own manifold mount CS1xx0 with or without display)</i>							
12	=	ISO Code >4/>6/>14							
13	=	ISO Code >2/>5/>15							
Display Options	_____	_____	_____	_____	_____	_____	_____	_____	_____
1	=	without display							
2	=	with display							
Fluids	_____	_____	_____	_____	_____	_____	_____	_____	_____
0	=	Hydraulic/Mineral Oil							
Analog Interfaces	_____	_____	_____	_____	_____	_____	_____	_____	_____
(omit)	=	4 - 20 mA <i>(Standard)</i>							
S	=	2 - 10V Analog Output							
Water Sensor Option	_____	_____	_____	_____	_____	_____	_____	_____	_____
(omit)	=	No Water Sensor <i>(None Standard)</i>							
AS-D	=	with AS3008 Water Sensor							
Control Options	_____	_____	_____	_____	_____	_____	_____	_____	_____
(omit)	=	Manually Controlled - Panel with Rheostat flow control and signal output <i>(Standard)</i>							
Power Options	_____	_____	_____	_____	_____	_____	_____	_____	_____
(omit)	=	24V DC <i>(Standard)</i>							
P	=	115V AC							
Air Suppression Loop	_____	_____	_____	_____	_____	_____	_____	_____	_____
(omit)	=	none							
L	=	Looped hose and fittings							

What's Included

- CS1000 Series Contamination Sensor
- Machined, 6061-T651 aluminum alloy manifold block with anodized surface treatment.
- Specially designed fitting for mating to pump/motor.
- Fluorocarbon elastomer (FKM) seals.
- Plugged water sensor port (G3/8 BSPP)
- VSD (Variable Speed Drive) Motor Power Supply and Control Cable
- Water Sensor (AS3008) Power Supply and Signal Cable (only supplied with optional water sensor (AS3008))
- Contamination Monitor (CS1000) output signal, USB-B Female Port for use with Windows-Based Computer and FluMoS Software, located on Control Enclosure
- Contamination Monitor (CS1000), output signal, M12 8 pole, Male Port, located on Control Enclosure, for use with PLC or RS485 Communication, analog or digital, 4 - 20 mA is standard, 2 -10 V is optional
- Flow control valve
- VSD (Variable Speed Drive) pump/motor
- Manual rheostat pump controller
- IP 40 enclosure
- Side or Front Inlet/Outlet Porting (SAE Size 04 ORB)
- 24 VDC Power Supply (NC3MP Female Connector)
- Optional 115 VAC Power Supply with Cord
- Contamination Monitor (CS1000) Power and Signal Cable
- Water Sensor (AS3008) M12 5 pole Signal Output Connection, Male Port, located on Control Enclosure
- Contamination monitor (CS1000) power connection, female M12 8 pole located on control enclosure
- Water sensor (AS3008) power connection, M12 5 pole Female located on control enclosure

CONTAMINATION MONITORS

HY Series

HY-TRAX – Telematics Communications Module with Remote Controlled Sampling System



Features and Benefits

- Provides Remote Visibility to the Fluid Condition of Critical Systems.
- Integrated micro VSD (Variable Speed Drive) driven, pump/motor provides optimal flow for accurate sensor readings in variable conditions.
- This HY-TRAX® Remote Oil Contamination Sensor Package allows remote access via the internet and smart devices to fluid particle counts, temperature, and percent water saturation levels (optional) displayed on a customizable dashboard. The fluid sampling system collects data and the communications module transmits this data via GSM cellular at scheduled intervals. Users can receive alerts via email when a fluid's ISO contamination code or water saturation level (optional) reaches user defined critical levels. The unit can sample fluid directly from a fluid reservoir or low pressure line (<50 psi).
- The Communications Module automatically controls fluid flow to compensate for viscosity changes due to temperature or fluid type. All data is transmitted through a secure VPN and archived in a protected database in the cloud to allow real-time and historical analysis.
- The HY-TRAX® Communications Module will provide maintenance managers with the visibility and vital information necessary to proactively schedule preventative maintenance on local and remote equipment. Maintenance decisions can now be based on accurate and real-time data.
- The communications module components are mounted and housed in a rugged IP 40 enclosure.
- Fluid sampling system standard with Fluorocarbon elastomer (FKM) seals.
- Fluid viscosities up to 1623 SUS (350 cSt).
- 50 psi (3.5 bar) max. working pressure.
- Flow control valve providing optimal pressure for accurate sensor readings.

Applications

- Mobile Equipment Technology
- Surface Mining
- Construction
- Monitoring of Oil Cleanliness in Storage Tanks
- Fleet Services
- Rail

Technical Specifications

Measuring Range	Display ISO ranges between 25/24/23 and 9/8/7 Calibration within the range ISO 13/11/10 to 23/21/18	
Contamination Output Code	Standard: ISO 4406:1999 or SAE AS 4059(D) Optional: ISO4406:1987; NAS 1638 and ISO 4406:1999	
Self-Diagnosis	Continuously with error indication via status LED	
Pressure Rating	50 psi (3.4 bar) max	
Fluid Inlet/Outlet	SAE ORB, Size 4	
Seal Material	Fluorocarbon elastomer (FKM)	
Pump Speed	500-5000 RPM (adjustable)	
Optimal Sampling Pump Flow Rate	0.008-0.079 GPM (30-300 mL/min)	
Fluid Temperature Range	32°F to 185°F (0°C to +85°C)	
Ambient Temperature Range	-22°F to 176°F (-30°C to 80°C)	
Max Viscosity	1622 SUS (350 cSt) max.	
Pump Type	Gear Pump	
Power Supply	24 volts DC	
Power Consumption	4A	
Communications Module Signal Output	GSM cellular Communication to monitoring website	
Electrical Safety Class	III (low voltage protection), IP 40 enclosure	
Cellular Communications	AT&T Quad Band GSM (850, 900, 1800, 1900 MHz)	
Weight and Dimensions		
Communications Module Control Sensor	HY-TRAX® Communications Module	Fluid Sampling Manifold w/ Communications Module & VSD Pump/Motor
	10 lbs. (4.5 kg)	20 lbs. (9.1 kg)
	14.7" x 11.3" x 5.25" (374 x 287 x 133 mm)	

Model Code

HY - 12 1 0 - - A - -

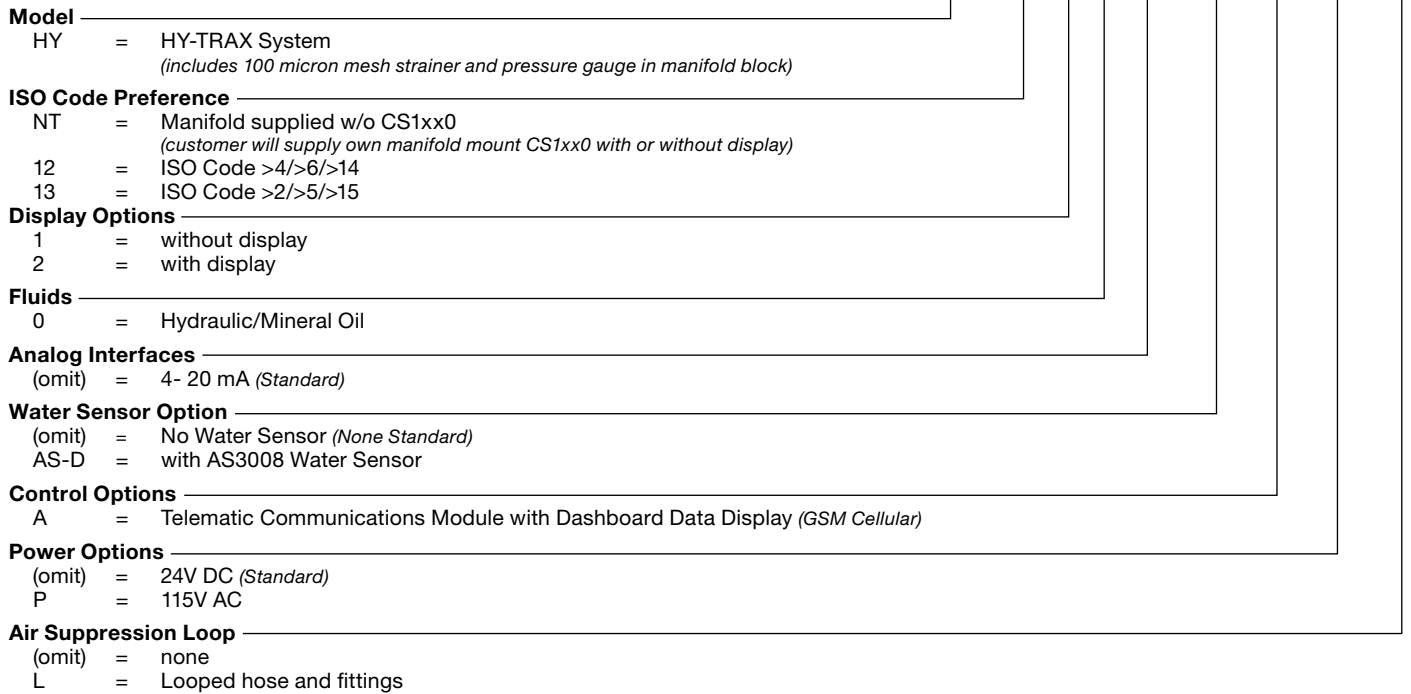

What's Included

- CS1000 Series Contamination Sensor
- Flow Control Valve
- GSM cellular communications
- VSD pump/motor
- Machined, 6061-T651 aluminum alloy manifold block with anodized surface treatment
- CS1000 Series Contamination Sensor (CS1000) Communications/Power Cable
- Specially designed fitting for mating to pump/motor
- Plugged water sensor port (G3/8 BSPP)
- IP 40 enclosure
- Water sensor (optional)
- 24V DC standard with optional 115V AC Power Supply
- Optional Water Sensor (AS3008) Communication/Power Cable
- Side or Front Inlet/Outlet Porting (SAE Size 04 ORB)

CONTAMINATION MONITORS

Example of HY-TRAX® Communications Modules Dashboard Contamination Chart

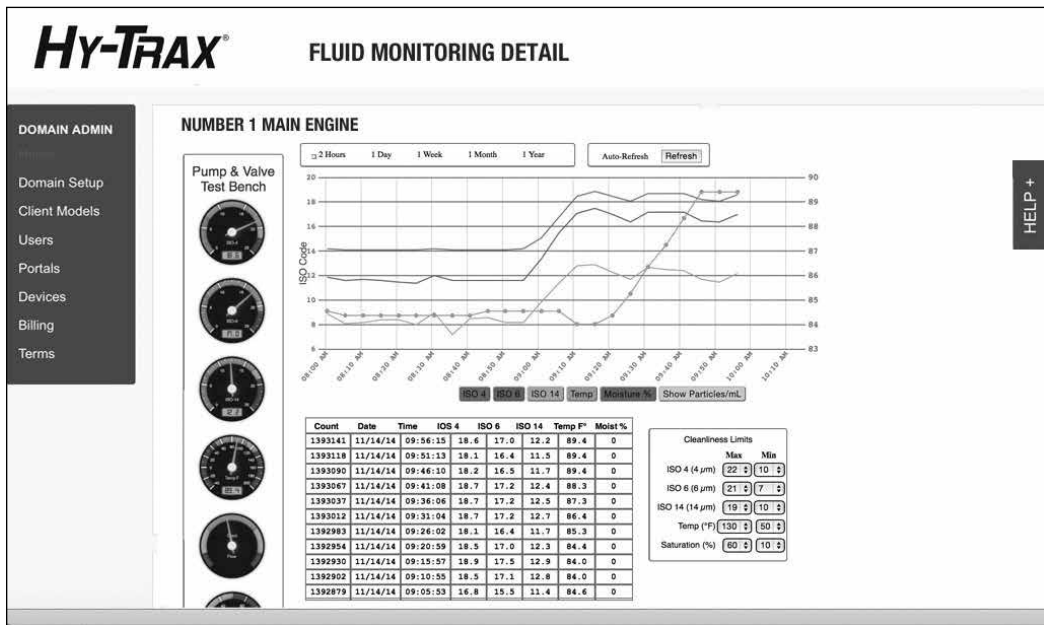

Example of HY-TRAX® Communications Modules Dashboard Gauge Panel

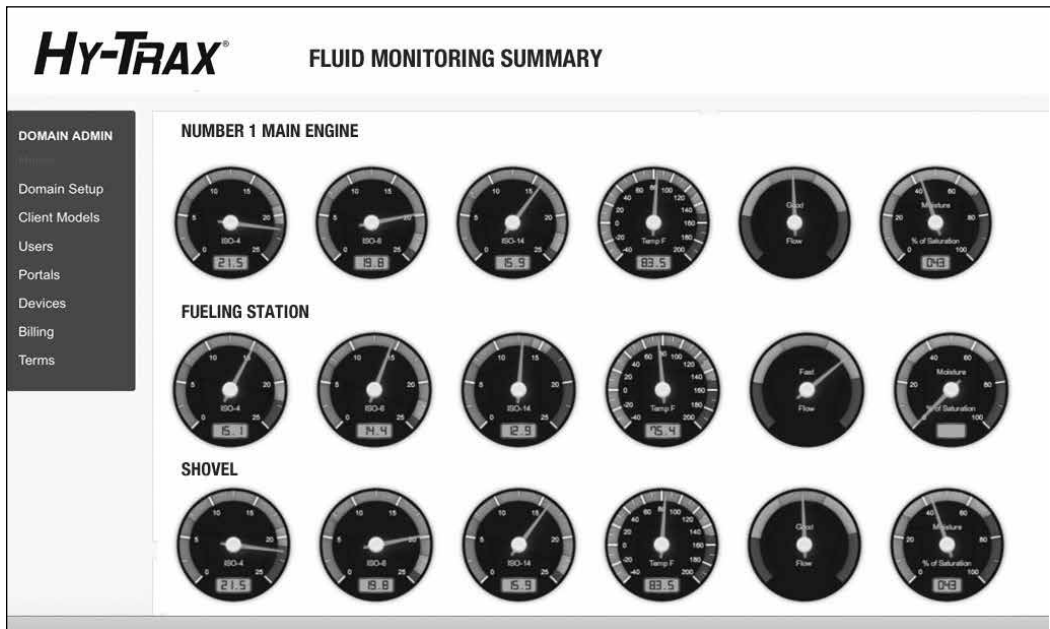

CONTAMINATION MONITORS

CS 2000 Series

Contamination Sensors

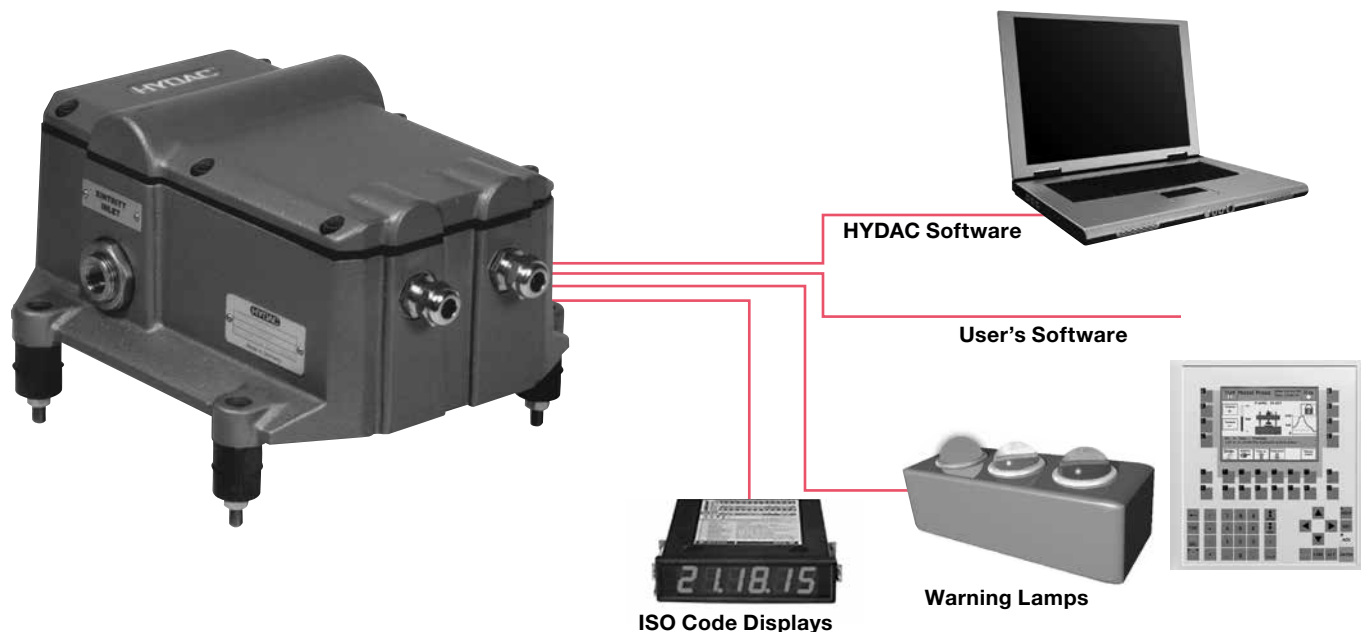

Description

The CS Contamination Sensor is a solid contamination sensor for detecting and monitoring solid contamination in hydraulic, lube and fuel oil. The CS Sensor continuously monitors the condition of the fluid and transmits the information to a variety of devices in real-time!

The data can be transmitted in various formats, allowing the user to display contamination levels, program alarms and/or warnings, activate or de-activate auxiliary filtration loops, or examine via HYDAC software.

The Sensor technology used is the same as that in our portable FCU series contamination monitors and has been proven as a successful means of detecting solid contamination particles.

The HYDAC sensor concept provides a distinct durability advantage: the CS Sensor is not sensitive to vibration, optical system contamination, pressure pulsations, fluid color, turbidity, or continuous high fluid temperatures.

Applications

This unit can be applied to any hydraulic system in which contamination monitoring is critical. It is designed for permanent installation in the system. Common applications of the CS Sensor include:

- Lube-oil systems
- Paper mills
- Power generation plants
- Steel mills
- Flushing Process Control
- Fuel oil systems

Technical Specifications

Self-diagnosis	Continuous with error indication via relays and serial interface
Measuring range (calibrated)	ISO 13/11/10 ... 23/21/18. Sensor calibrated within this range. Displays from ISO class 12/10/09 up to ISO 25/23/21.
Operating pressure Inlet Outlet	Max. 580 psi (40 bar); depending on the model Max. 145 psi (10 bar); rated to 5075 psi (350 bar)
Connections Inlet Outlet	Thread G 1/4, ISO 228 Thread G 1/4, ISO 228
Measurement flow rate	10 - 200 ml/min
Total flow rate	10 - 800 ml/min (depending on pressure)
Fluid temperature range	32° to 158°F (0° to 70°C)
Power supply voltage	24 VDC, ± 25%
Power consumption	25 Watt maximum
Electrical data	- Output for Contamination Sensor Display - 3 relay outputs: - 1 x "ready" relay - 2 x "limit" relays - PLC output - Additional electrical output (see model code)
Ambient temperature range	32° to 131°F (0° to 55°C)
Storage temperature range	-8° to 185°F (-20° to 85°C)
Relative Humidity	max. 90%, non-condensing
Electrical safety class	III (safety extra-low voltage)
IP class	IP65
Weight	8.8 lbs. (4 kg)

Data Output To

- PC - via HYDAC software (included)
- Programmable logic controllers (PLC)
- Warning lamps via relays
- Local ISO class display (customer supplied)
- 4 to 20mA or DIN-Messbus or Ethernet

Model Code

		CS	21	3	0	- 1	- U	/ - 1	- 2
Series	_____								
CS	=	Contamination Sensor							
Model	_____								
21	=	3 digit ISO 4406 Code (>2/>5/>15)							
22	=	3 digit ISO 4406 Code (>4/>6/>14)							
Enclosure	_____								
3	=	Stationary							
Fluids	_____								
0	=	Standard mineral fluids and mineral based synthetics							
1	=	Phosphate esters (e.g. Skydrol, Hyjet)							
Modification Number	_____								
1	=	Standard							
Supply Voltage	_____								
U	=	24 VDC							
Pressure Range	_____								
1, 2, 3, 4	=	See Pressure / Viscosity Range chart							
Output	_____								
0	=	RS232 (DIN-66348 protocol) (enables easy communication with Hydac FluMoS Software)							
1	=	4 - 20 mA							
2	=	RS485 (DIN-66348 protocol)							
5	=	Ethernet (TCP/IP)							

* For pressures above 560 psi - Reduce the pressure to between 280 and 560 psi. Please contact HYDAC for details.

Model Codes containing RED are non-standard items - Minimum quantities and longer lead times may apply - Contact HYDAC for information and availability

Pressure / Viscosity Range

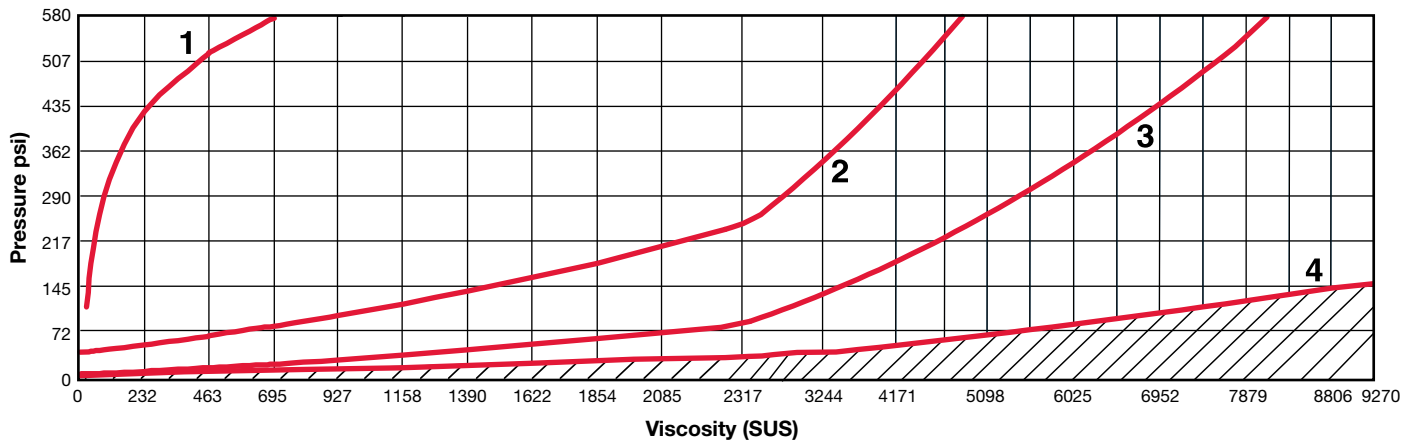

Dimensions

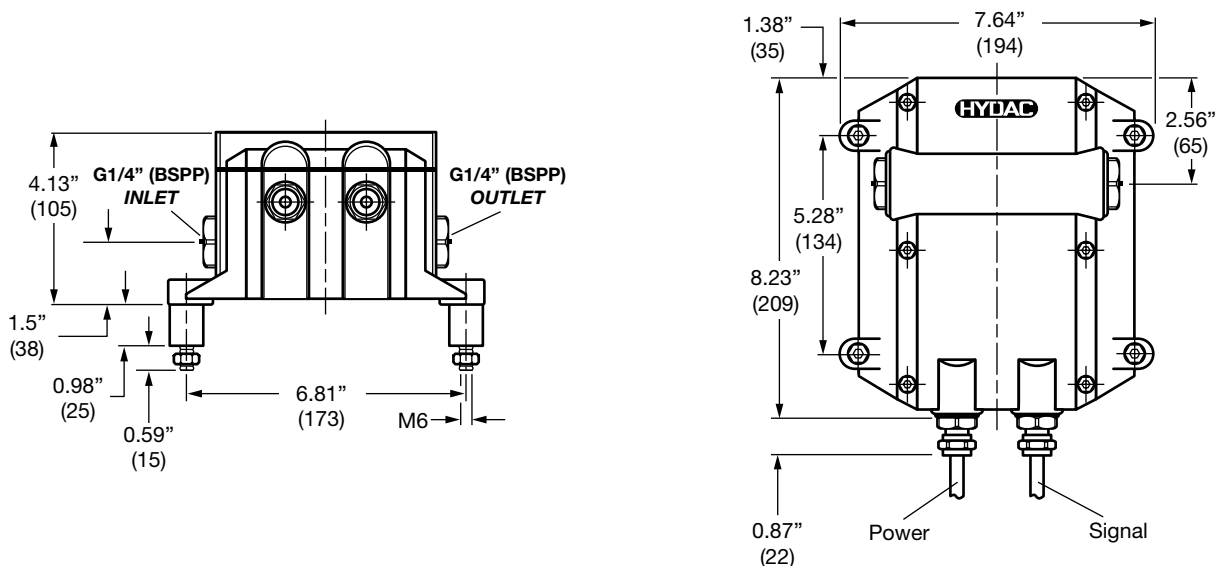

Dimensions are for general information only, all critical dimensions should be verified by requesting a certified print.

CONTAMINATION MONITORS

CSM 1000 Series

Contamination Sensor Module



Description

The Contamination Sensor Module CSM 1000 is an online condition monitoring system for detecting particle contamination in hydraulic and lubrication fluids containing a high proportion of air bubbles. Air bubble suppression is used to dissolve the air bubbles so that they are not detected as particles. Moreover, it is the ideal solution for analyzing the particle content of fluids, independently of the rest of the hydraulic system. As an option other condition monitoring sensors such as the HYDAC AquaSensor can be incorporated.

Applications

- Lubrication oil system in paper, steel and energy sectors
- For condition-based, pro-active maintenance
- Monitoring of component cleanliness on test rigs
- Monitoring of oil cleanliness in oil reservoirs

Advantages

- Cost-effective, self-contained solution
- Numerous data interfaces provide communication via WLAN, intranet or internet
- Online monitoring of the oil cleanliness with alarm function to indicate:
 - ingress of and increase in contamination
 - increase in contamination as components start to wear when there are filtration problems
- Verification of cleanliness on test rigs
- Verification of changes in the oil cleanliness as a result of inadequate servicing.

Hydraulic Schematic

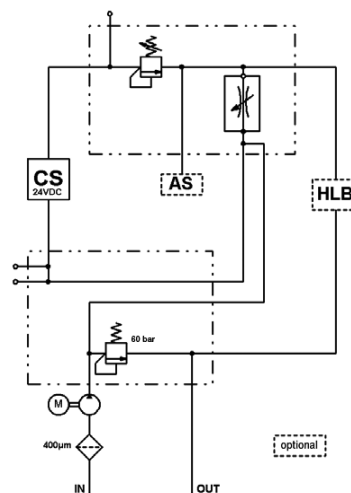

Technical Specifications

Pump type	Gear pump
Operation pressure	
P_{in} (INLET)	-5.8 to 7.3 psi (-0.4 to 0.5 bar) (std. pump) -5.8 to 1740.5 psi (-0.4 to 120 bar) (pump, pressure inlet stable)
P_{out} (OUTLET)	72.5 psi (5 bar)
P_{out} (leakage line)	7.3 psi (0.5 bar) (pump, pressure inlet stable)
Permissible outlet pressure	72.5 psi (5 bar max)
Connections	INLET: Thread G 1/4, ISO 228] G1/4 (BSPP) OUTLET: Thread G 1/4, ISO 228] (BSPP)
Total flow rate	approx. 100 ml/min (standard pump) approx. 180 ml/min (pump, pressure inlet stable)
Permissible operating viscosity range	59 to 13905 SUS (10 to 3000 cSt)
Permissible viscosity range for measuring	59 to 4635 SUS (10 to 1000 cSt)
Permissible Fluid temperature range	32° to 158°F (0° to 70°C)
Permissible fluids	Hydraulic and lubrication fluids based on mineral oil
Power consumption (motor pump group)	0.18 kW @ 50 Hz 0.21 kW @ 60 Hz
Ambient temperature range	32 to 131°F (0° to 55°C)
Storage temperature range	-4 to 185°F (-20 to 85°C)
Relative humidity	max. 90%, not condensing
IP class	IP55
Weight	approx. 40 lbs (18 kg)
Contamination Sensor	
Self-diagnosis	continuously with error indication via status LED
Measuring range	MIN / MAX Display of class ISO 9/8/7 (MIN) to class ISO 25/24/23 (MAX) Calibrated within the range ISO 13/11/10 to ISO 23/21/18.
Power supply voltage	9 to 36 VDC, residual ripple <10%
Power consumption	3 Watt max
Electrical outputs	- Analog output 4 to 20 mA or 2 to 10 V - RS485 Interface - Switching output

Model Code

CSM 1 2 2 0 - 1 - 1 - W/N/X60/O60 -

- Series** _____
- CSM = Contamination Sensor Module
- Resolution Contamination Sensor** _____
- 1 = 4 particle size channels
- Contamination Codes** _____
- 2 = ISO 4406:1999; SAE AS 4059
(D) / > 4 µm(c) > 6 µm(c) > 14 µm(c) > 21 µm(c)
- 3 = ISO 4406:1987; NAS 1638 / > 2 µm > 5 µm > 15 µm > 25 µm
ISO 4406:1999; SAE AS 4059
(D) / > 4 µm(c) > 6 µm(c) > 14 µm(c) > 21 µm(c) reversible
- Options** _____
- 1 = without display
- 2 = with display (display rotation of 270°)
- Fluids** _____
- 0 = based on mineral oil
- Hydraulic Version** _____
- 1 = Standard pump
- 2 = Pump, increased inlet pressure, with oil leakage pipe
- Electrical Output Contamination Sensor** _____
- 1 = 4 to 20 mA analogue output
- 2 = 2 to 10 V analogue output
- 4 = Pump increased inlet pressure, no oil leakage pipe, magnetic drive
- Supply Voltage Motor Pump Unit** _____
- W/N/X60/O60 = 230 V, 50 Hz, 3Ph/ 265 V, 60 Hz, 3Ph, delta connection
400 V, 50 Hz, 3Ph/ 460 V, 60 Hz, 3Ph, star connection
- N/AB/N60/AB60 = 400 V, 50 Hz, 3Ph/ 400 V, 60 Hz, 3Ph, delta connection
690 V, 50 Hz, 3Ph/ 690 V, 60 Hz, 3Ph, star connection
- Supplementary Details** _____
- AS = with AquaSensor AS 1000 Series

Items Supplied:

- CSM
- Operating and Maintenance Instructions
- CD with FluMoS software and manuals
- Calibration Certificate Contamination Sensor

Model Codes containing RED are non-standard items – Minimum quantities and longer lead times may apply - Contact HYDAC for information and availability

Dimensions

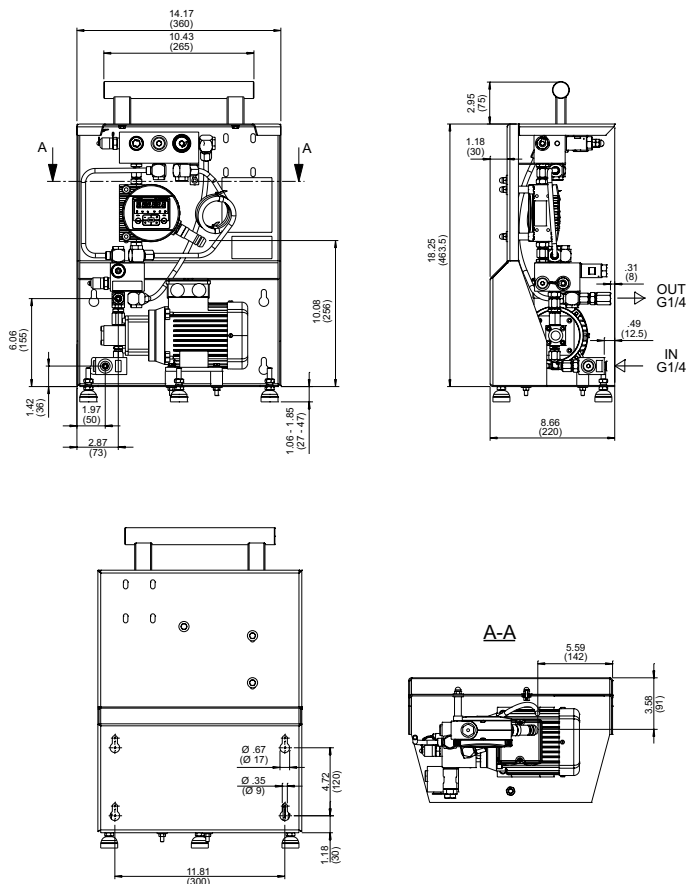

Accessories for

CS 1000	Part No.
Contamination Sensor Interface CSI-D-5	03249563
Connector with 2 m cable, screened, 8-pole, M12x1	03281220
Connector with 5 m cable, screened, 8-pole, M12x1	02702459
Extension cable 5 m, socket 8-pole, M12x1 / plug 8-pole, M12x1	03281240
Connector with screw clamp, screened, 8-pole, M12x1	03281243
AS 1000	Part No.
ZBE 08 Right-angled connector, 5 pole, M12x1	06006786
ZBE 08S-02 Right-angled connector, with 2 m cable, screened, 5 pole, M12x1	06019455
ZBE 08S-05 Right-angled connector with 5 m cable, screened, 5 pole, M12x1	06019456
ZBE 08S-10 Right-angled connector with 10 m cable, screened, 5 pole, M12x1	06023102

Dimensions are inches (millimeters) and for general information only, all critical dimensions should be verified by requesting a certified print.

CONTAMINATION MONITORS

CSM 2000 Series

Contamination Sensor Module



Description

The Contamination Sensor Module CSM 2000 is an online condition monitoring system for detecting particle contamination in hydraulic and lubrication fluids containing a high proportion of air bubbles. Air bubble suppression is used to dissolve the air bubbles so that they are not detected as particles. Moreover, it is the ideal solution for analyzing the particle content of fluids, independently of the rest of the hydraulic system. As an option, other condition monitoring sensors such as the HYDAC AquaSensor can be incorporated.

Applications

- Lubrication oil system in paper, steel and energy sectors
- For condition-based, pro-active maintenance
- Monitoring of component cleanliness on test rigs
- Monitoring of oil cleanliness in oil reservoirs

Advantages

- Cost-effective, self-contained solution
- Numerous data interfaces provide communication via WLAN, intranet or internet
- Online monitoring of the oil cleanliness with alarm function to indicate:
 - ingress of and increase in contamination
 - increase in contamination as components start to wear when there are filtration problems
- Verification of cleanliness on test rigs
- Verification of changes in the oil cleanliness as a result of inadequate servicing.

Hydraulic Schematic

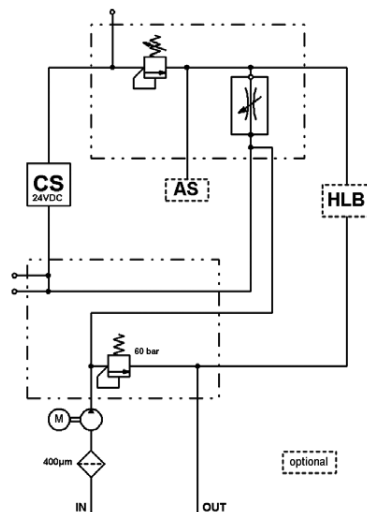

Technical Specifications

Pump type	Gear pump
Operation pressure	
P_{in} (INLET)	-5.8 to 7.3 psi (-0.4 to 0.5 bar) (standard pump) -5.8 to 1741 psi (-0.4 to 120 bar) (pump, pressure inlet stable)
P_{out} (OUTLET)	72.5 psi (5 bar)
P_{out} (leakage line)	7.3 psi (0.5 bar) (pump, pressure inlet stable)
Permissible outlet pressure	72.5 psi (5 bar max)
Connections	INLET: Thread G 1/4, ISO 228 OUTLET: Thread G 1/4, ISO 228
Total flow rate	approx. 100 ml/min (standard pump) approx. 180 ml/min (pump, pressure inlet stable)
Permissible operating viscosity range	59 to 13905 SUS (10 to 3000 cSt)
Permissible viscosity range for measuring	59 to 4635 SUS (10 to 1000 cSt)
Permissible Fluid temperature range	32° to 158°F (0° to 70°C)
Permissible fluids	Hydraulic and lubrication fluids based on mineral oil
Power consumption (motor pump group)	0.18 kW @ 50 Hz 0.21 kW @ 60 Hz
Ambient temperature range	32 to 131°F (0° to 55°C)
Storage temperature range	-4 to 185°F (-20 to 85°C)
Relative humidity	max. 90%, not condensing
IP class	IP55
Weight	approx. 40 lbs (18 kg)
Contamination Sensor	
Self-diagnosis	continuously with error indication via status LED
Measuring range	MIN / MAX Display of class ISO 9/8/7 (MIN) to class ISO 25/24/23 (MAX) Calibrated within the range ISO 13/11/10 to ISO 23/21/18.
Power supply voltage	9 to 36 VDC, residual ripple <10%
Power consumption	3 Watt max
Electrical outputs	- Analog output 4 to 20 mA or 0 to 10 V - RS485 Interface - Switching output

Model Code

CSM 2 2 3 0 - 1 - 1 - W/N/X60/O60 -

Series

CSM = ContaminationSensor Module

Resolution Contamination Sensor

2 = 4 particle size channels

Contamination Codes

2 = ISO 4406:1999; SAE AS 4059 (D) / > 4 μm(c) > 6 μm(c) > 14 μm(c) > 21 μm(c)

3 = ISO 4406:1987; NAS 1638 / > 2 μm > 5 μm > 15 μm > 25 μm
 ISO 4406:1999; SAE AS 4059 (D) / > 4 μm(c) > 6 μm(c) > 14 μm(c) > 21 μm(c) rev.

Contamination Sensor

3 = Standard

Fluids

0 = based on mineral oil

Hydraulic Version

1 = Standard pump (up to 0.5 bar)

2 = Pump with increased inlet pressure, with leakage line

Electrical Output ContaminationSensor

0 = RS232 (DIN-66348 protocol)

1 = Analog output (4-20mA)

2 = RS485 (DIN-66348 protocol)

5 = Ethernet (IEEE 802.3 TCP/IP)

Supply Voltage Motor Pump Unit

W/N/X60/O60 = 230 V, 50 Hz, 3Ph/ 265 V, 60 Hz, 3Ph, delta connection

400 V, 50 Hz, 3Ph/ 460 V, 60 Hz, 3Ph, star connection

N/AB/N60/AB60 = 400 V, 50 Hz, 3Ph/ 400 V, 60 Hz, 3Ph, delta connection

690 V, 50 Hz, 3Ph/ 690 V, 60 Hz, 3Ph, star connection

Options

AS = with AquaSensor AS 1000 Series

Items Supplied:

- CSM
- Operating and Maintenance Instructions
- CD with FluMoS Software and manuals
- Calibration Certificate Contamination Sensor

Model Codes containing RED are non-standard items – Minimum quantities and longer lead times may apply - Contact HYDAC for information and availability

Dimensions

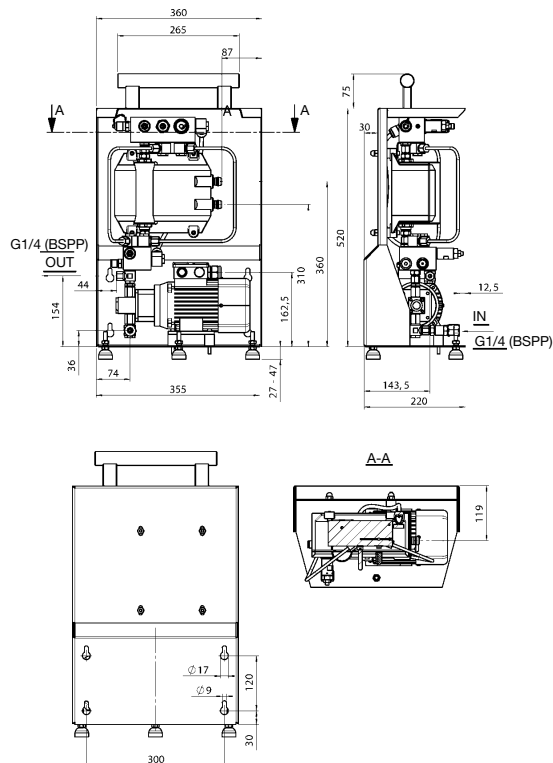

Accessories for:

CS 2000	Part No.
Contamination Sensor Display CSD-1-U	03078272
Connector with 6.5 ft. (2 m) cable, screened, 8-pole, M12x1	03281220
Connector with 16.4 ft. (5 m) cable, screened, 8-pole, M12x1	02702459
Extension cable 16.4 ft. (5 m), socket 8-pole, M12x1 / plug 8-pole, M12x1	03281240
Connector with screw clamp, screened, 8-pole, M12x1	03281243
AS 1000	Part No.
ZBE 08 Right-angled connector, 5 pole, M12x1	06006786
ZBE 08S-02 Right-angled connector, with 6.5 ft. (2 m) cable, screened, 5 pole, M12x1	06019455
ZBE 08S-05 Right-angled connector with 16.4 ft. (5 m) cable, screened, 5 pole, M12x1	06019456
ZBE 08S-10 Right-angled connector with 32.8 ft. (10 m) cable, screened, 5 pole, M12x1	06023102

Dimensions are millimeters and for general information only, all critical dimensions should be verified by requesting a certified print.

CONTAMINATION MONITORS

FCU 1000 Series

Fluid Control Units - Portable Models



FCU1310



FCU 1315

Description

The FluidControl Unit FCU 1000 is a portable service unit, designed for the temporary measurement of solid particle contamination, water saturation and fluid temperature in hydraulic systems as well as Diesel fuels.

The integrated pump and the hoses contained in the FCU 1000 series scope of delivery allow operation in

- control circuits (oil hydraulics only)
- pressure circuits (oil hydraulics only) and
- pressureless reservoirs (oil hydraulics and Diesel fuels)

Important Instructions / Restrictions

- Designed for hydraulic oils (*viscosity range 10 to 350 cSt*)
- Designed for temporary operation up to max. 30 minutes, followed by a rest period of 10 minutes (*no continuous operation*)
- Operating pressure: -7.25 to 650 psi (-0.5 to 45 bar), with pressure adaptor: 215 to 5000 psi (15 to 345 bar)
- Not designed as a Bottle Sampler (*minimal volume of 300 ml is required for a bottle sample analysis*)

Applications

- Hydraulic systems
- Service for mobile hydraulics
- Maintenance
- Diesel storage, transfer, and filling

Features

- Two contamination calibrations in one instrument (reversible)
 - ISO 4406:1987; NAS 1638
 - ISO 4406:1999; SAE AS 4059 (D)
- Saturation and temperature measurement through the built-in AquaSensor 1000
- Integrated pump for measurement in pressureless reservoirs
- Operation with 24V DC network adaptor included in scope of delivery
- Interfaces: 5-pole plug, Bluetooth, USB data port

Technical Specifications

General Data	
Self-diagnosis	continuously with error indication via status LED and display
Display	LED, 6 / 4 / 4 digits, in 17 segment format
Measured Value	ISO code/ SAE Class / NAS Class / Saturation level / Temperature
Measuring Range	Display from ISO code 9/8/7 (MIN) to ISO code 25/24/23 (MAX) Calibrated within the range ISO 13/11/10 to 23/21/18 Saturation level 0 to 100% / Temperature -13° to 212°F (-25 to 100°C)
Accuracy	+/-1/2 ISO class in the calibrated range / $\leq \pm 2\%$ Full scale max.
Seal Material	FPM
Ambient Temperature Range	32 to 113°F (0 to 45°C)
Storage Temperature Range	-40 to 176°F (-40 to 80°C)
IP class	IP 50 in operation IP67 closed
Weight	approx. 29 lbs (13 kg)
Hydraulic Data	
Operating Pressure	in: -7.25 to 650 psi (-0.5 to 45 bar) out: 0 to 7.5 psi (0 to 0.5 bar)
with Adaptor for Pressure Lines	in: 217 to 5000 psi (15 to 345 bar) out: 0 to 7.5 psi (0 to 0.5 bar)
Pressure max.	5000 psi (345 bar)
Measurement Flow Rate	30 to 300 ml/min (<i>viscosity dependant</i>)
Maximal Suction Height	1 m
Permissible Viscosity Range with Adaptor for pressure lines	46 to 1622 SUS (10 to 350 cSt)
Fluid Temperature Range	32 to 158°F (0 to 70°C)
Electrical Data	
Power Supply Voltage	24 V DC $\pm 20\%$, residual ripple < 10%
Max. Power / Current Consumption	100 Watt / 4 A
Interface	Bluetooth via FluMoS Mobile App Plug connection, 5-pole, male, M12x1

We do not guarantee the accuracy or completeness of this information. The information is based on average working conditions. For exceptional operating conditions please contact our technical department. All details are subject to technical changes.

Model Code

FCU 1 3 1 0 - 4 - U - AS - 1

Series	FCU = Fluid Control Unit	FCU	1	3	1	0	-	4	-	U	-	AS	-	1
Model	1 = 1000 Series, 4 particle size channels													
Contamination Code	2 = ISO 4406 : 1999, SAE AS 4059 (D) > 4 µm(c), >6 µm(c) and >14 µm(c)													
	3 = ISO 4406:1987; NAS 1638 / 2-5 µm, 5-15 µm, 15-25 µm, > 25 µm ISO 4406:1999; SAE AS 4059 (D) / > 4 µm(c) > 6 µm(c) > 14 µm(c) > 21 µm(c)													
														reversible between
Housing	1 = for Hydraulic and lubrication fluids based on mineral oils													
	5 = Hydraulic and lubrication fluids based on mineral oils as well as diesel													
Fluids	0 = Mineral Oil, Synthetic Esters/PAO, Quintolubric, Cosmolubric (Consult factory for other fluid types.)													
Options	4 = with Integrated Pump													
Supply Voltage	U = 24 V DC													
Integrated Sensor	Z = Without AS (only available with FCU1210 option)													
	AS = AquaSensor (AS 1000 series)													
Power Supply Adapter	1 = 100 to 240 V AC / 50/60 Hz / 1 Phase, (Europe, USA/Canada, UK, Australia, Japan)													

Model Codes containing RED are non-standard items – Minimum quantities and longer lead times may apply - Contact HYDAC for information and availability

Scope of Delivery

- Fluid Control Unit FCU 1000
- Power supply AC adaptor with connecting cables to supply voltage for Europe, USA/Canada, UK, Australia, Japan
- Adaptor for pressure lines
- INLET pressure hose with screw connection for Test Point 1620, black, length = 6.7 ft. (2 m)
- INLET suction hose, open end, transparent, length = 6.7 ft. (2 m) (only FCU 1315)
- INLET suction hose, open end, clear, length = 1 ft. (0.3 m)
- INLET Bottle Sampling suction pipe, angled
- OUTLET return hose, open end, clear, length = 3.3 ft. (1 m)
- Operating and Maintenance Instructions / Calibration certificate
- Ground cable; ESD protection (only FCU 1315)
- USB Memory Stick
- CD with FluMoS Light Software and manuals

Accessories

- Battery pack - P/N 03504605
- Cable with universal plug (for cigarette lighter or socket from supply system on board), L = 32.8 ft. (10 m) - P/N 03306236
- Field Verification Start-up Kit - P/N 3443253
- Field Verification Refill Kit - P/N 3443249

Dimensions

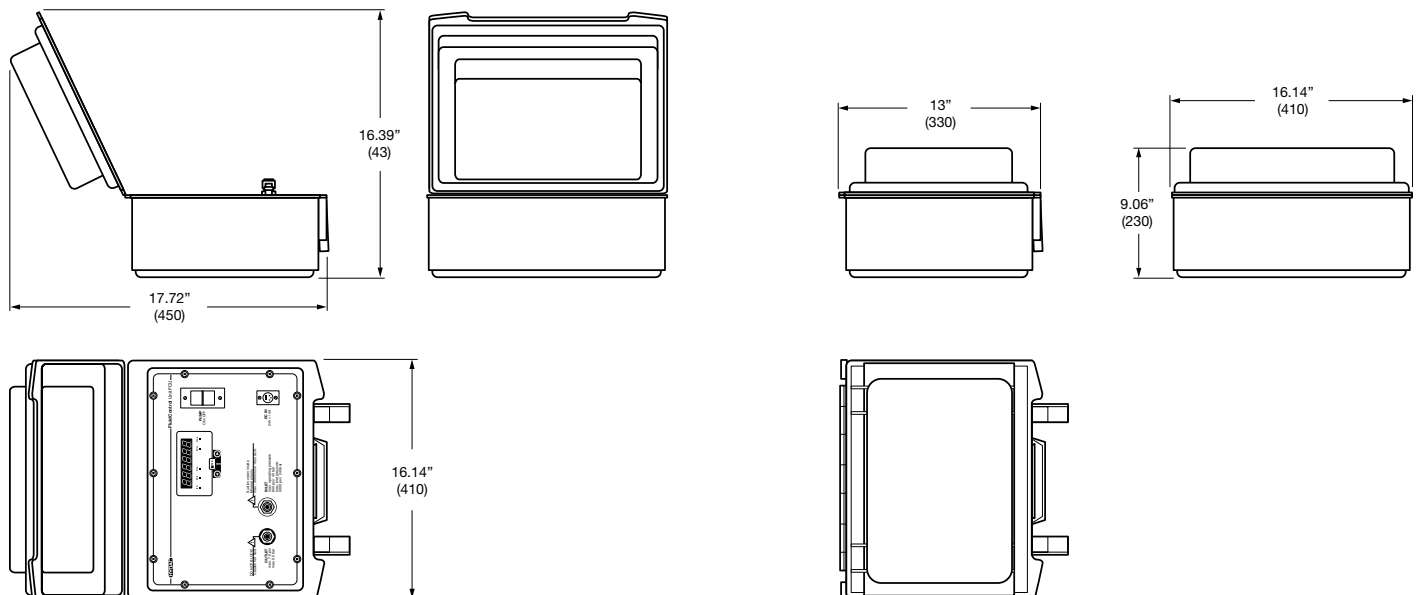

Dimensions are for general information only, all critical dimensions should be verified by requesting a certified print.

CONTAMINATION MONITORS

FCU 2000 Series

Fluid Control Units



FCU 2000-1



FCU 2000-4

Description

The FCU 2000 Series Fluid Control Unit is the second generation of diagnostic equipment for measuring and controlling contamination in hydraulic and lubrication systems. These Units are portable, which makes them ideal for use on multiple machines in a plant, or in-the-field use. The rugged construction incorporates a folding handle which also serves as a prop stand for viewing angle adjustment.

Online Measurement

A key advantage of the FCU is that it allows the user to measure changes in contamination instantaneously as they occur. The unit continuously detects solid particles and displays the results in cleanliness classes according to ISO 4406 (1992 or 1999), SAE AS 4059 or NAS 1638 standards.

Tank Extraction

The FCU 2000-4 model is equipped with a specific suction inlet and an integrated pump for reservoir, in addition to the standard online measurement capability.

Comprehensive Reporting

Measurements are automatically stored in memory and can be used to print tabular and graphic reports in a wide variety of formats. Although extensive functions for data recording and documentation are available, clear built-in menus make it easy for a user to develop highly informative reports with minimal training.

PC Capability

For many applications, the built-in printer will produce the necessary reports. In addition, data can be transmitted to a PC via an RS232C interface, providing the user with flexibility in analysis with the supplied FluMoS light software package, or with standard packages like MS-EXCEL.

Contamination Control

By means of control software, the user can program the FCU to activate an auxiliary filtration unit through built-in relays when contamination reaches a specified maximum level. This makes it possible to control system cleanliness reliably and automatically.

The FCU also can be programmed to de-activate an off-line unit when contamination reaches a preset target level, an especially useful feature in flushing operations.

Applications

The versatility and simplicity of the FCU 2000 Series is advantageous in various applications:

- Preventive maintenance
- Field service
- System production and testing
- Fluid cleanliness documentation
- Flushing process control

Technical Specifications

	FCU 2100	FCU 2200
Particle size channels	2µm / 5µm / 15µm / 25µm	4µm _(c) / 6µm _(c) / 14µm _(c) / 21µm _(c)
Measurement Range	NAS 2 to 12 ISO 13/11/10 to 23/21/18	SAE 2 to 12 ISO 13/11/10 to 23/21/18
Indication Range	NAS 2 to 15 ISO 12/10/9 to 25/23/21	SAE 2 to 15 ISO 12/10/9 to 25/23/21
Accuracy	± 1/2 class (ISO, NAS, SAE)	
Calibration	ISO 4402	ISO 11943
Recalibration	Recommended every 2 years	
Log Memory	Can accommodate up to 3000 measured values / 100 Test Headers	
Inlet Operating Pressure	45 to 5000 psi (3 to 345 bar)	
Outlet Flow Rate	800 ml/min max	
Outlet Operating Pressure	max 45 psi (3 bar) back pressure	
Measurement Flow Rate	50 - 150 ml/min	
Permissible Viscosity Range	32 to 4635 SUS (1 to 1000 cSt) (inlet port, see graph below) / 32 to 696 SUS (1 to 150 cSt) (suction port, continuous operation) / 696 to 1622 SUS (150 to 350 cSt) (suction port, brief operation, 10 min.)	
Fluid Temperature Range	32 to 160°F (0 to 71°C)	
Supply Voltage	24 V DC, ± 25% or 110 V AC with supplied adapter	
Wattage	25 W max	100 W max
Battery Powered Operating Duration	Measurement without pump or pump supplied externally: up to 6 hours	
Serial Port	RS 232 with 15-pin Sub D plug	
Ambient Temperature Range	0 to 130°F (-17.8 to 54.4°C)	
Storage Temperature Range	-4 to 185°F (-20 to 85°C)	
Relative Humidity	max 90%, non-condensing	
Protection Type	IP40	
Weight	approx. 30 lbs (13.6 kg)	

The minimum inlet pressure required to achieve a flow rate of 100 ml/min for a given viscosity can be found by referring to the graphic below. The required inlet pressure increases with increasing clogging of the filter element.

Pressure Required at the FCU High-Pressured Port (inlet) for a Flow Rate of 100 ml/min (Flow regulator opened, new filter element)

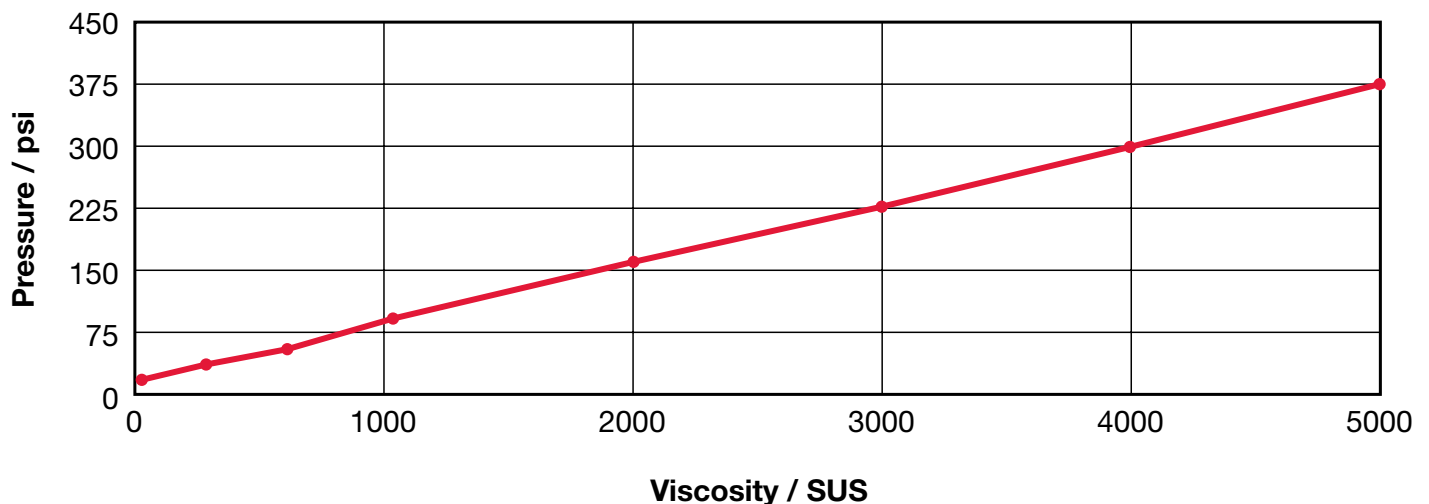

CONTAMINATION MONITORS

Model Code

	FCU	22	10	1	K	KIT
Series	FCU = Fluid Control Unit					
Model	21 = 3 digit ISO 4406 Code (>2/>5/>15µm) and NAS 1638 22 = 3 digit ISO 4406 Code (>4/>6/>14µm) and SAE AS 4059					
Media	10 = Mineral Oil 11 = Phosphate Ester/Skydrol (not available with pump option -4)					
Options	1 = without Integrated Pump 4 = Integrated Pump					
Supply Voltage	K = 110V AC					
Component Package	KIT = Includes Components					

- Minimes Adapter to SAE-6
- One Inlet and One Outlet Hose
- FluMoS Light Software Package (CD supplied with Unit – Also available for download from www.hydac.com)
- PC Cable
- Power Adapter
- Instruction Manuals
- Shipping Case

Additionally for FCU 2xxx-4:

- Second power adapter
- Suction hose 6mm bore (1m length)
- Suction hose 6mm bore (0.2m length)

Model Codes containing RED are non-standard items – Minimum quantities and longer lead times may apply - Contact HYDAC for information and availability

FCU Accessories

FCU Accessories	Part Number
Aluminum Transport Case for FCU-1 Series	00349153
Aluminum Transport Case for FCU-4 Series	03040814
Printer Paper (5 rolls)	00349155
Printer Ink Ribbon	00349156
Line Adapter 110V AC	03090803
High Pressure Hose (6.5 feet)	00349150
Return Hose (6.5 feet)	00349151

TestPoints available in HYDAC Hydraulic Accessories catalog PN#02080105

Dimensions FCU 2000-1

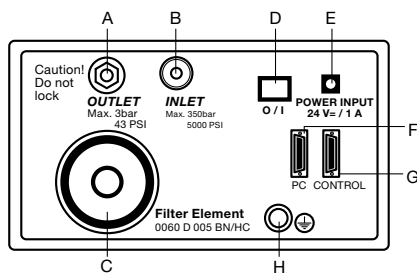
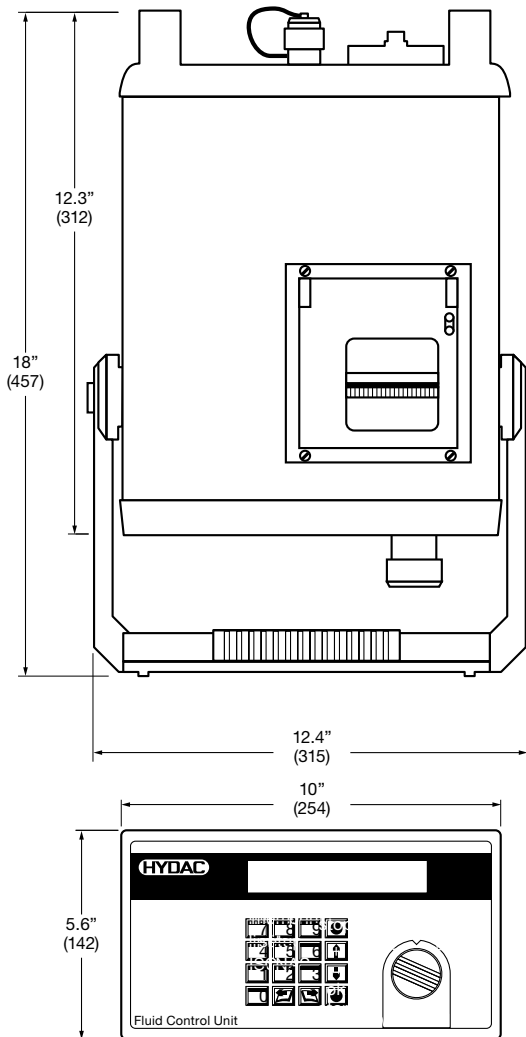

- A** = Outlet (return flow to tank)
- B** = Inlet (high pressure port)
- C** = Filter Cover
- D** = On/Off Switch
- E** = Power Supply Connection (main)
- F** = PC Connector (serial port)
- G** = Control Connector
- H** = Case Ground

FCU 2000-4

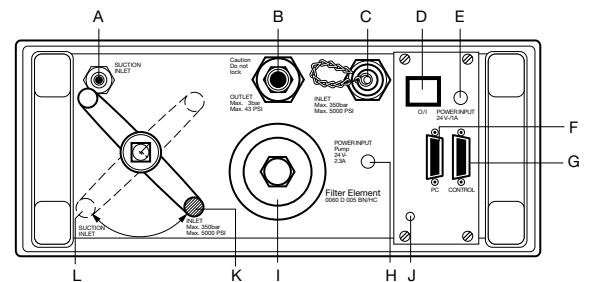
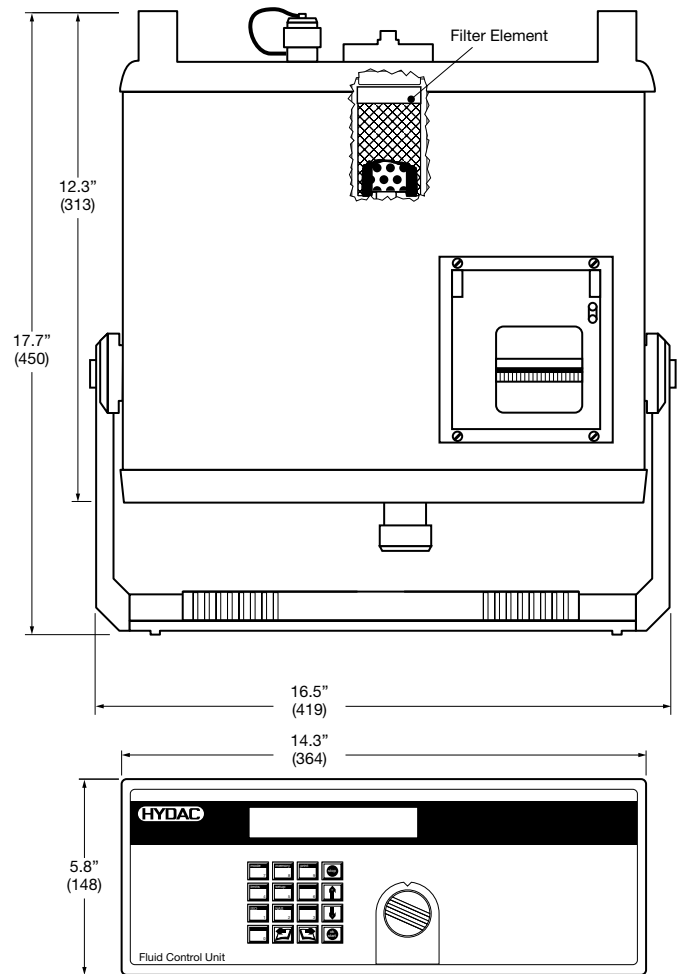

- A** = Suction Inlet (suction port)
- B** = Outlet (return flow to tank)
- C** = Inlet (high pressure port)
- D** = On/Off Switch
- E** = Power Supply Connection (main)
- F** = PC Connector (serial port)
- G** = Control Connector
- H** = Power Supply Connection (pump)
- I** = Filter Cover
- J** = Case Ground
- K** = Ball Valve (for INLET/high pressure port)
- L** = Ball Valve (for SUCTION INLET/suction port)

Dimensions are for general information only, all critical dimensions should be verified by requesting a certified print.

CONTAMINATION MONITORS

RBSA Series

Reservoir Breather Fluid Sampling Adapter



Description

The RBSA is an aluminum adapter that gives easy access to a hydraulic oil reservoir for fluid sampling. The Reservoir Breather Adapter gives the user access to the hydraulic oil to more easily determine the real-time particulate and water saturation contamination data.

Features

- Drop-in reservoir breather retrofit for fluid sampling provides clean easy access to the reservoir through the existing breather part
- Provides easy fluid quality sampling solution for HY-TRAX® and FCU1310 suction and return ports
- Hytrax adapter kit includes #6 & #4 JIC adapters with 6' connection hoses included
- FCU1310 adapter includes 1620 testpoint and 3' connection hose to FCU1310
- 24" SS drop tubes can be cut to length
- Standard 6 bolt breather pattern
- Anodized 6061 aluminum breather
- 3/4" NPT for breather element

Mounting Pattern

Customer is responsible to cut an appropriately sized hole on top of their tank. This adapter has two (2) ports: one for Suction and one for Return. Also includes a breather port.

Reservoir pattern is six (6) .203" holes on a 4.94" BCD with a 4.25" diameter center hole. See Drawing S-1048.

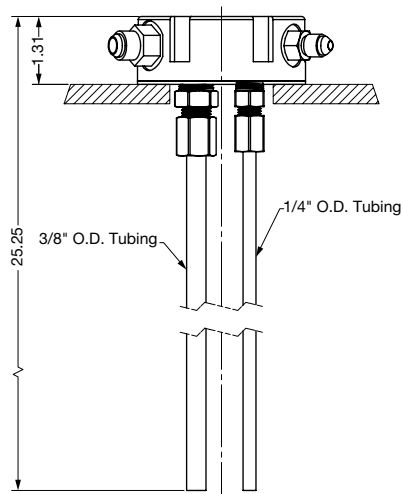
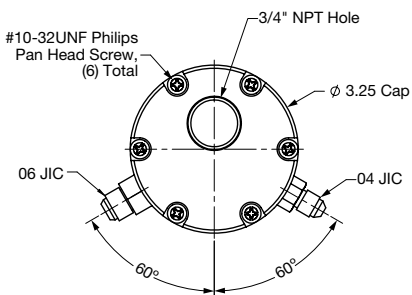
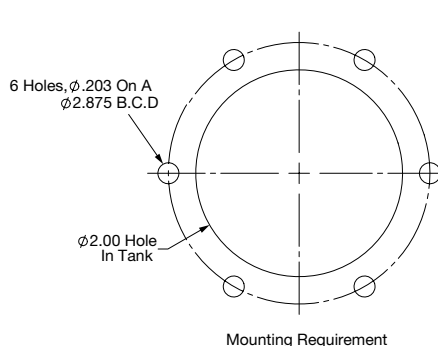

Applications

- All applications with a hydraulic reservoir utilizing a 6-bolt mounting connection

Technical Specifications

Reservoir Mounting Pattern:	Fits standard 6-bolt
Supply Port Thread Size:	9/16-18 UN
Return Port Thread Size:	7/16-20 UN
Breather Port Thread Size:	3/4" NPT
Fittings:	Option 1: Includes #4 & #6 JIC fittings. Optional #6 & #4 JIC fittings and 6' supply/return hoses. Option 2: Includes 1620 test point and TMU connection hose.
Return Tubes:	Supplied with 3/8" and 1/4" return tubes. Tubes are 24" long and can be shortened if necessary. Housing constructed 6061 anodized aluminum.

Model Code

RBSA - 1

Series

RBSA = Reservoir Breather Fluid Sampling Adapter

Options

- 1 = HY-TRAX® adapter fitting #6 & #4 JIC fittings and 6' supply/return hoses
- 2 = FCU1310 adapter (suction hose included)

Application Example

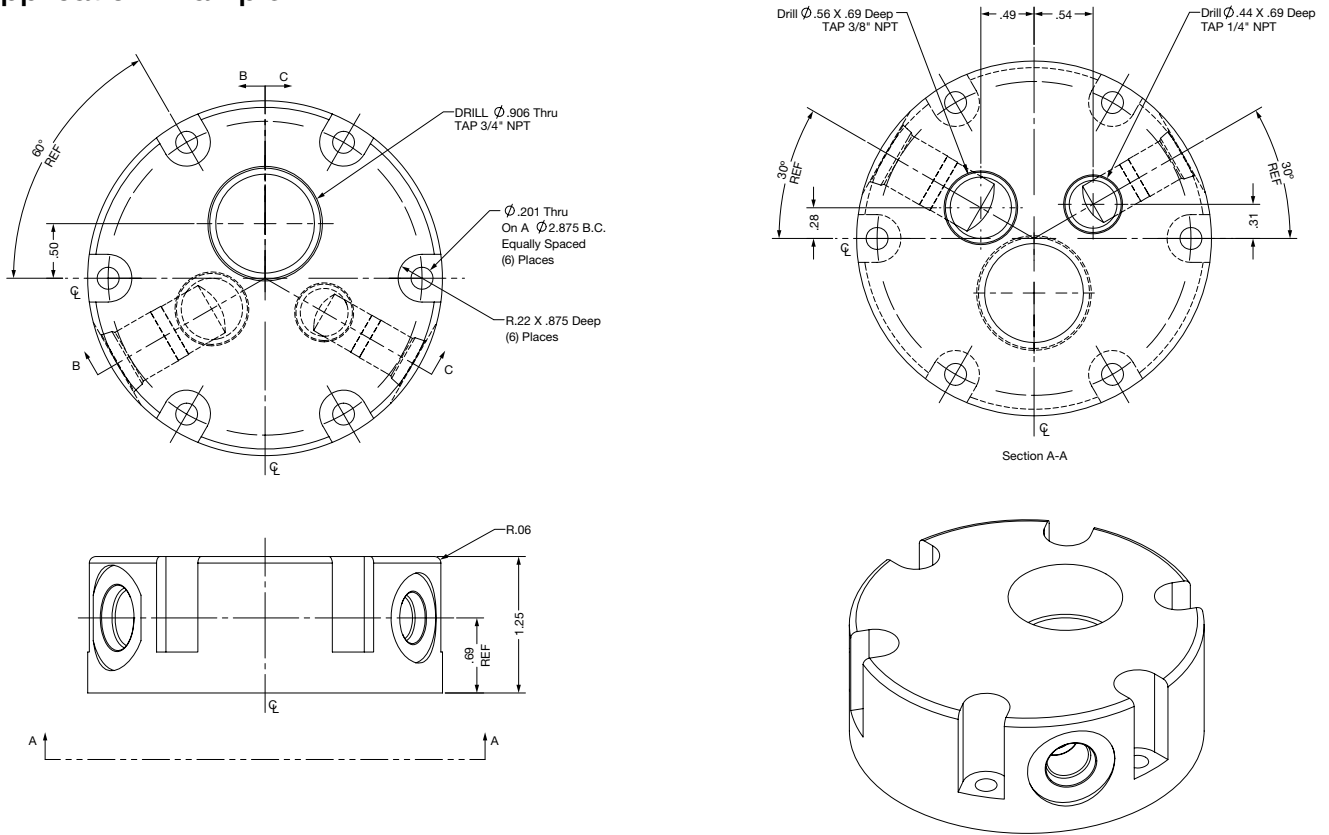

Mounting Views

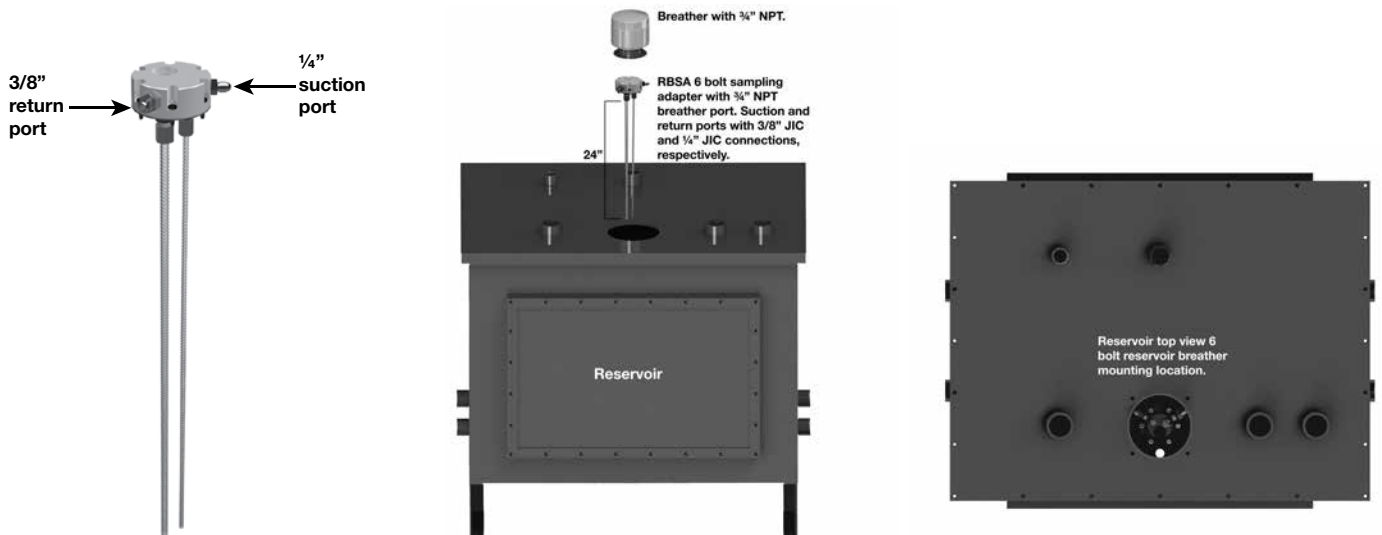

MCS Series

Metallic Contamination Sensor



Description

The Metallic Contamination Sensor MCS 1000 detects metallic solid particle contamination in lubrication fluid. The particles are determined according to the inductive measurement process, in which a coil system is the key element of the sensor. Metallic particles (ferromagnetic Fe and nonferromagnetic nFe) in the > 70 µm size range are detected.

The MCS 1000 continuously monitors the status of the system and gives information on imminent gear unit damage. This makes the sensor a reliable instrument for status-oriented maintenance.

Features

- Early detection of imminent gear unit damage
- Prevention of expensive plant downtime
- Optimal supplement to optical sensors
- Measurement of metallic particles (ferromagnetic and non-ferromagnetic) > 70 µm
- Measurement result is not affected by air bubbles or liquid contamination in the liquid

Applications

- Wind Turbines
- Marine Thrusters
- Industrial Gear Boxes
- Mobile Drive Systems
- Lubrication Systems
- Flushing Systems
- Test Stands

Technical Specifications

General Data	
Ambient temperature	-40 to 158°F (-40 to 70°C)
Diameter sensor cross-section	MCS1310 = 1/4" (6.35mm) MCS1410 = 1/2" (12.7mm) MCS1510 = 1" (25.4 mm)
Protection class to DIN 40050	IP 67
Weight	approx. 8 lbs (3.5 kg)
Dimensions (L x W x H)	3.3" x 6.4" x 5.5" (83 x 162 x 140 mm)
Vibration	10 - 58 Hz 58 - 500 Hz
	0.75 mm (amplitude) 10 g (acceleration)
Shock	40 g
Hydraulic Data	
Flow rate	Up to 200 l/min
Operating pressure	20 bar max.
Fluid temperature range	-40 to 185°F (-40 to 85°C)
Inlet / Outlet	Flange connection, SAE 4" according to ISO 6162-1
External Electrical Data	
Supply voltage	9 ... 36 V DC, residual ripple < 10%
Power consumption	5 W max.
Internal Electrical Data	
2 Configurable switching outputs (<i>n-switching Power MOSFET, normally-open</i>)	1 x Ferromagnetic particles (Fe) 1 x Non-ferromagnetic particles (nFe) or 1 x Ferromagnetic particles (Fe) + Non-ferromagnetic (nFe) 1 x Status signal
Alarm relays capacity	1.5 A max.
RS485 interface	2 wire, half duplex
HSI interface	1 wire, half duplex
Detection limits	
Ferromagnetic (Fe) particles	MCS1510 = > 200 µm MCS1410 = > 100 µm MCS1310 = > 70 µm (particle with volume equivalent to that of a sphere with given Ø)
Non-Ferromagnetic (Fe) particles	MCS1510 = > 550 µm MCS1410 = > 300 µm MCS1310 = > 200 µm (particle with volume equivalent to that of a sphere with given Ø)

We do not guarantee the accuracy or completeness of this information. The information is based on average working conditions. For exceptional operating conditions please contact our technical department. All details are subject to technical changes.

Model Code

		MCS	1	5	1	0	-	5	-	0	/	000
Series	_____											
MCS	=	Metallic Contamination Sensor										
Model	_____											
1	=	1000 Series										
Contamination Code	_____											
3	=	particles > 70 µm										
4	=	particles > 100 µm										
5	=	particles > 200 µm										
Options	_____											
1	=	Standard (Switching Outputs/HSI)										
2	=	modbus/RS485										
7	=	TCP/Ethernet										
Fluids	_____											
0	=	Mineral and synthetic oils (particular used in wind power industry)										
Hydraulic connection	_____											
1	=	Flange Connection, SAE 1/2" according to ISO 6162-1 (only for MCS13xx)										
2	=	Flange Connection, SAE 3/4" according to ISO 6162-1 (only for MCS14xx)										
5	=	Flange connection, SAE 4" according to ISO 6162-1 (only for MCS15xx)										
Electrical Installation	_____											
0	=	Standard										
Modification number	_____											
000	=	Standard										

Scope of Delivery

- MCS 1000
- O-ring (47.22x3.53 NBR 70 Shore)
- O-ring (110.72x3.53 NBR 70 Shore)
- Operating and maintenance instructions

Accessories

- SAE 4" Flange adaptor set for pipe or hose connection, 42L according ISO 8431-1 Consisting of: 2x Flange adaptors, 2x O-rings, 8x Cylinder screws, 8x Washers, 8x Spring washers, P/N: 3435426
- Flange adaptor plate, SAE 4" – SAE 1½", P/N: 3442518
- Socket plug (female) with 6.5 ft. (2 m) line, shielded, 8-pole, M12x1, P/N: 3281220
- Socket plug (female) with 16.4 ft. (5 m) line, shielded, 8-pole, M12x1, P/N: 02702459
- Extension cable 16.4 ft. (5 m), Socket plug (female) 8-pole, M12x1 / Socket plug (male) 8-pole M12x1, P/N: 3281240
- Socket plug with screw clamp, 8-pole, M12x1, P/N: 3281243

Dimensions

Flange connection, SAE 4" according to ISO 6162-1

MCS with accessory flange adaptor set (optional)

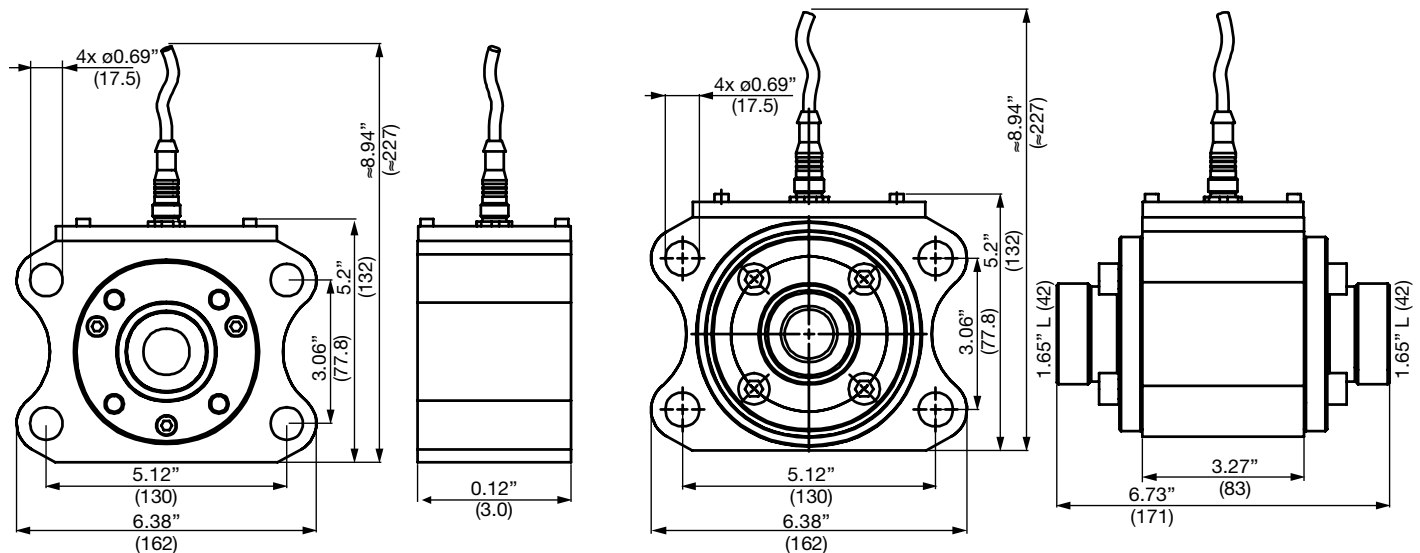

Dimensions are for general information only, all critical dimensions should be verified by requesting a certified print.

CONTAMINATION MONITORS

AS 1000 Series

Aqua Sensor



Description

The Aqua Sensor AS 1000 is a fluid sensor for detecting water in hydraulic and lubrication fluid, especially designed as OEM sensor for fluid condition monitoring.

The sensor measures the water content relative to the saturation concentration (saturation point) and outputs the saturation level (0 to 100%) as a 4 - 20 mA signal. A reading of 0% would indicate fluid that is free of water, while a reading of 100% would indicate a fluid that is saturated with water.

The AS 1000 can be used to simultaneously determine the temperature of the oil and output it as a 4 to 20 mA signal as well.

In so doing, the AS 1000 enables hydraulic and lubrication fluids to be monitored accurately, continuously and on-line.

Water in Oil

It is almost certain that there is water present in hydraulic and lubrication systems. These systems should be operated without the presence of free or emulsified water. The most common sources of water entering a system are ambient humidity, "splash" from process water, and new oil. Water contamination will accelerate the aging process of the oil resulting in oil oxidization, additive depletion, reduced lubrication, corrosion and damaged components. Most of these costly problems can be avoided by monitoring the water content of the operating fluids.

Sometimes the water content is difficult to determine, but with the HYDAC Aqua Sensor, determining the amount of water is easy! The most practical method for monitoring water content in oil is as a percent of the saturation level. Different oils are capable of dissolving varying amounts of water, therefore they have varying water saturation curves. The curve (below) is an example of the typical relationship of water saturation level versus fluid temperature in hydraulic and lubrication oils. By looking at the example graph it can be seen that this fluid is capable of holding more water, or has a higher saturation level, as the temperature increases.

Applications

- Hydraulic systems that are sensitive to water
- Gear boxes
- Molding machines
- Turbines
- Transferrers

Technical Specifications

Input Data	
Measuring range (<i>temperature</i>)	-13 to 212°F (-25 to 100°C)
Measuring range (<i>saturation level</i>)	0 to 100%
Operating pressure	max. 725 psi (40 bar)
Burst pressure	> 9000 psi (620 bar)
Parts in contact with fluid	Stainless steel, FPM seal, ceramic with evaporated metal
Output Data - Humidity Measurement	
Output level (<i>saturation level</i>)	4 to 20 mA
Calibrated accuracy	≤ ± 2% FS max.
Accuracy in media measurements	≤ ± 3% FS typ.
Pressure dependent	+ 0.02% FS / bar
Output Data - Temperature Measurement	
Output signal (<i>temperature</i>)	4 to 20 mA or 2-10V
Accuracy	≤ ± 2% FS max.
Nominal temperature range (<i>measuring saturation level</i>)	32° to 194°F (0° to 90°C)
Ambient temperature range	-40° to 212°F (-40° to 100°C)
Viscosity range	32 to 23175 SUS (1 to 5000 cSt)
Flow velocity	< 16 ft/sec (4.88 m/sec)
Permissible fluids	Fluids based on mineral oil and synthetic and natural esters
CE mark	EN 50081-1, EN 50081-2, EN 50082-1, EN 61000-6-2
Type of Protection acc. DIN 40050	IP67
Other Data	
Supply voltage	12 to 32 V DC
Residual ripple	≤ 5%
Thread connection	G 3/8 BSPP male thread
Torque rating	approx. 18 ft/lbs (24.4 Nm)
Electrical connection Pin 1: +Ub Pin 2: Signal saturation level Pin 3: 0V / GND Pin 4: Signal temperature Pin 5: not connected	M12x1.5 pole (DIN VDE 0627)
Reverse polarity protection of the supply voltage, excess voltage, override and short circuit protection	Standard
Weight	approx. 5 oz (142 g)

Note: FS (Full Scale) = relative to the full measuring range

Example of a Hydraulic Oil Saturation Curve

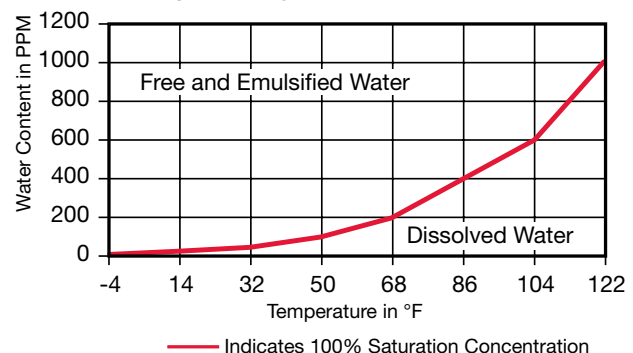

Model Code

AS 1 0 0 8 - C - 000

Series

AS = Aqua Sensor

Measuring Range

1 = Saturation level 0 to 100%; Temperature -13°F to 212°F (-25°C to 100°C)

Fluids

0 = Mineral oils
1 = Phosphate esters (HFD-R)

Mechanical Connection

0 = G 3/8A DIN 3852

Electrical Connection

8 = Plug M12x1, 5-pole (connector not included)

Signal Technology

C = Saturation level 4 to 20 mA (0 to 100%), Temperature 4 to 20 mA -13°F to 212°F (-25°C to 100°C)

Modification Number

000 = Standard

Items supplied

- Aqua Sensor
- Operation Manual

Dimensions

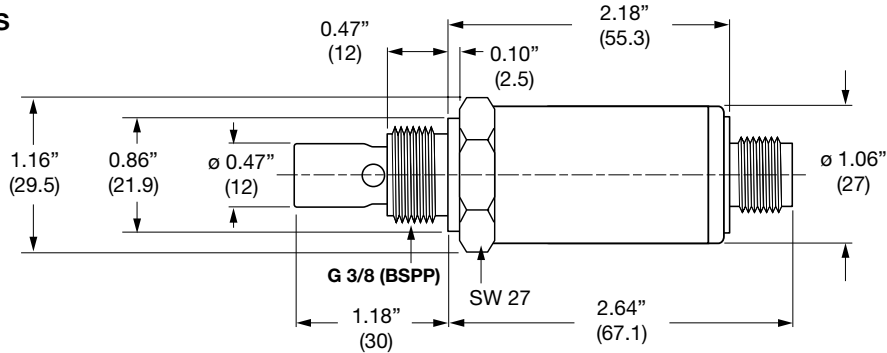

Dimensions are for general information only, all critical dimensions should be verified by requesting a certified print.

Circuit Connection

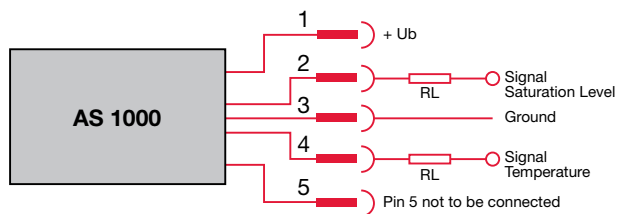

Color Codes for connectors with cables:

- 1 = brown
- 2 = white
- 3 = blue
- 4 = black
- 5 = gray

AS 1000 G1/4 Housing Block Adapter

Part #03182134
Purchase separately

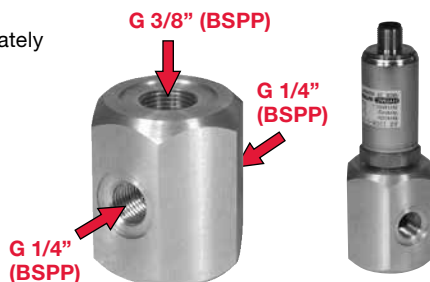

Accessories

ZBE 08 Connector

5 Pole M12x1 90°

ZBE 08 connector only (IP65)

Part #06006786

ZBE 08-02-4 with 6.5 ft. (2 m) (IP67)

Part #06006792

ZBE 08-05-4 with 16.4 ft. (5 m) cable (IP67)

Part #06006791

HDA 5500-0-0-AC-000 Display

Part #00908861

HDA 5500-0-0-DC-000 Display

Part #00908862

HDA 5500-1-0-DC-000 Display

Part #00908868

HDA 5500-1-1-AC-000 Display

Part #00908869

HDA 5500-1-1-DC-000 Display

Part #00908870



CONTAMINATION MONITORS

AS 3000 Series

Aqua Sensor



Description

The Aqua Sensor AS 3000 is the further development of the proven AS 1000 series for the online detection of water in oils, particularly as a sensor for condition monitoring.

It records the water saturation and the temperature of the operating fluid. The display allows you to view the current measured values or to adjust the parameter settings.

The measured values are output as a 4 to 20 mA signal and are the basis for two parameterizable switching outputs. The AS 3000 thus enables hydraulic and lubricating oils to be monitored accurately, continuously and online.

Applications

- Mobile hydraulics
- Hydraulics and lubrication systems in industry

Advantages

- 4 digit digital display, can be aligned in two axes
- User-friendly due to key programming
- Individual configuration
- Reliable on account of its compact, rugged design
- Economical sensor
- No calibration necessary for different oil types
- Pressure-resistant, even with pulsations
- Early detection of water problems thus preventing faults and unnecessary interruption to operations

Technical Specifications

Input Data	
Measuring range (<i>temperature</i>)	-13° to 212°F (-25° to 100°C)
Measuring range (<i>saturation level</i>)	0 to 100%
Operating pressure	-7.25 to 725 psi (-0.5 to 50 bar)
Burst pressure	9136 psi (≤ 630 bar)
Flow velocity	max. 16.4 ft/s (5 m/s)
Parts in contact with fluid	Connection part: Stainless steel / ceramic with evaporated metal Seal: FKM or EPDM
Output Data - Humidity Measurement	
Output level (<i>saturation level</i>)	4 to 20 mA
Calibrated accuracy	≤ ± 2% FS max.
Accuracy in media measurements	≤ ± 3% FS typ.
Pressure dependent	+ 0.02% FS / bar
Output Data - Switching Outputs	
Version (<i>parameterizable</i>)	PNP transistor outputs Closer or opener Default settings: opener
Allocation (<i>parameterizable</i>)	Saturation level or temperature Default: saturation level Alarm 80% (SP 2), warning 60% (SP 1), Activation temp: 86° F / 30° C
Switch current	max. 1.2 A per output
Switch cycles	> 100 million
Output Data - Ambient Conditions	
Nominal temperature range (<i>measuring saturation level</i>)	32° to 176°F (0° to 80°C)
Storage temperature range	-40° to 80°F (-40° to 176°C)
Fluid temperature range	-40° to 80°F (-40° to 176°C)
Viscosity range	32 to 23175 SUS (1 to 5000 cSt)
Permissible fluids	Fluids based on mineral oil and synthetic and natural esters
CE mark	EN 61000-6-1/2/3/4
Type of Protection acc. DIN 40050	IP67
Other Data	
Supply voltage	18 to 35 V DC
Residual ripple	≤ 5%
Thread connection	G 3/8 BSPP male thread
Torque rating	approx. 18 ft/lbs (24.4 Nm)
Electrical connection	M12x1.5 pole (DIN VDE 0627)
Display	4-digit, LED, 7 segment, red, height of digits 0.28" (7 mm)
Weight	approx. 3.88 oz (110 g)

Note: FS (Full Scale) = relative to the full measuring range

Model Code

AS 3 0 0 8 - 5 - 000

Series

AS = Aqua Sensor

Measuring Range

3 = 3000 Series

Fluids

0 = Mineral oils

1 = Phosphate esters (HFD-R)

Mechanical Connection

0 = G 3/8A DIN 3852

Electrical Connection

8 = Plug M12x1, 5-pole (connector not included)

Signal Technology

5 = 2 switch outputs / 1 analog output

Modification Number

000 = Standard

Items supplied

- Aqua Sensor
- Operation Manual

Dimensions

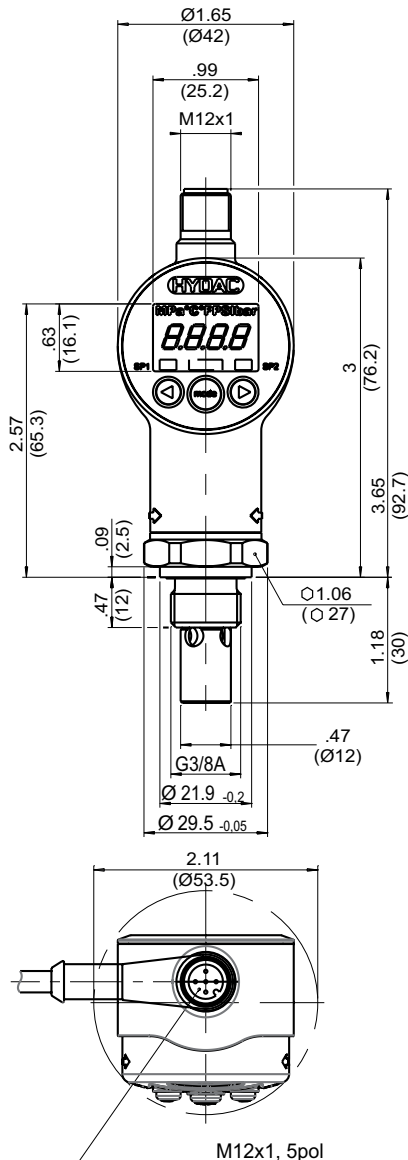

Accessories

ZBE 08 Connector

Female connector, bent, shielded, 5 Pole, M12x1
Part #6006786

ZBE 08S-02

Female connector, bent, with 6.5 ft. (2m) lead, shielded,
5 pole, M12x1
Part #6019455

ZBE 08S-05

Female connector, bent, with 16.4 ft. (5m) lead, shielded,
5 pole, M12x1
Part #6019456

ZBE 47S-05

Female connector, straight, with 16.4 ft. (5m) lead, shielded,
5 pole, M12x1
Part #3527626

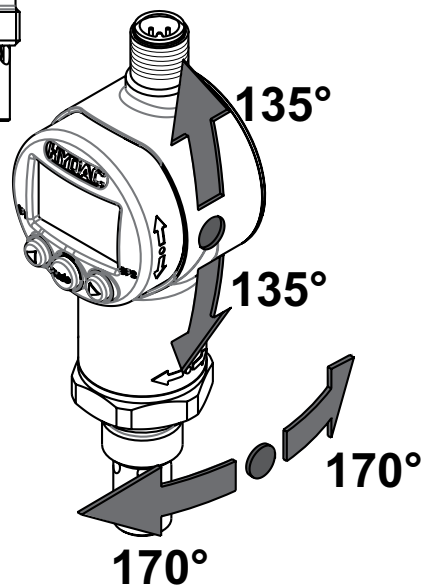

Dimensions are inches (millimeters) and for general information only, all critical dimensions should be verified by requesting a certified print.

CONTAMINATION MONITORS

SMU 1200 Series

Sensor Monitoring Unit



Description

The Sensor Monitoring Unit SMU 1200 is a display unit for HYDAC fluid sensors and is designed to display and store measured data. The following combinations of fluid sensors can be connected directly:

- Contamination Sensor CS 1000 & Aqua Sensor AS 1000
- Metallic Contamination Sensor MCS 1000 & Aqua Sensor AS 1000

Advantages

- **Data is stored in the SMU with a date and time stamp. Data can be viewed and stored in real-time using bluetooth interface and FluMoS Mobile App.**
- Simple installation parallel to the customer system (*HYDAC Sensor Interface HSI for SMU 1200, transfer of the sensor's own analog and switching outputs*).
- Simple installation using the magnetic holder or DIN rails.
- Plug & Work unit including the 16.4' (5m) connection cable required for direct connection of the sensors (*sensor connections via M12x1 male connectors, no programming necessary*).
- Measured values can be read from the standard USB memory stick supplied via the USB master port.
- Simple data processing and data evaluation using MS-Excel or HYDAC FluidMonitoring Software FluMoS (*'light version' available as freeware at www.hydac.com*).
- Program restarts independently once voltage is restored; no loss of measured data.

Technical Specifications

Mounting position	Optional
Self-diagnostics	Continuously with error indication on display
Display	LED, 6/4/4-digit, each with 17 segments
Rough handling (to IEC/EN 60068-2-31)	Drop height 2" (50 mm)
Ambient temperature	32°F – 13°F (0 °C to +55 °C)
Storage temperature range	-40°F – 176°F (-40 °C to 80 °C)
Relative humidity	Maximum 95%, non-condensing
Weight	≈ 2.2 lb (≈ 1 kg)
Electrical Data	
Supply voltage	12 to 24 V DC (±10%) The SMU must not be used with vehicle supply systems without load dump protection of maximum 30 V DC.
Residual ripple	≤ 5%
Power consumption	15 Watt, 1.25 A max.
Accuracy of the real-time clock	± 5 s/day / ± 0.5 h/year
Clock buffer	≈ 20 years
Protection rating	III (safety extra-low voltage)
Protection class	IP 67

Model Code

SMU 1 2 6 0 - TU - 00 / 000

Type	SMU					
SMU	=	Sensor Monitoring Unit				
Series	1					
1	=	1000 Series				
Data input	2					
2	=	Digital				
Interface	6					
6	=	HSI + USB Master				
7	=	Ethernet + USB Master				
Application	0					
0	=	Standard				
Supply voltage	TU					
TU	=	12 to 24 V DC				
Sensor combination	00					
00	=	CS 1000	B	AS 1000		
10	=	MCS 1000	B	AS 1000		
Customer modification number	000					
000	=	Customer modification number				

Items supplied

- 1 SMU 1200 series
- 1 USB memory stick
- 1 connection cable 5 pole with flying leads for power supply, L = 16.4' (5m)
- 2 connection cables appropriate to the sensor combination, L = 16.4' (5m)
- 1 FluMoS light CD
- 1 User manual
- 1 DIN rail, L = 7.87" (20 cm)

Accessories

Power supply PS5,
100-240 V AC / 50-60 Hz / 1.1 A -> 24 V DC / 1000 mA,
Cable length = 3.28' (1.8 m) PN: 3399939

Dimensions

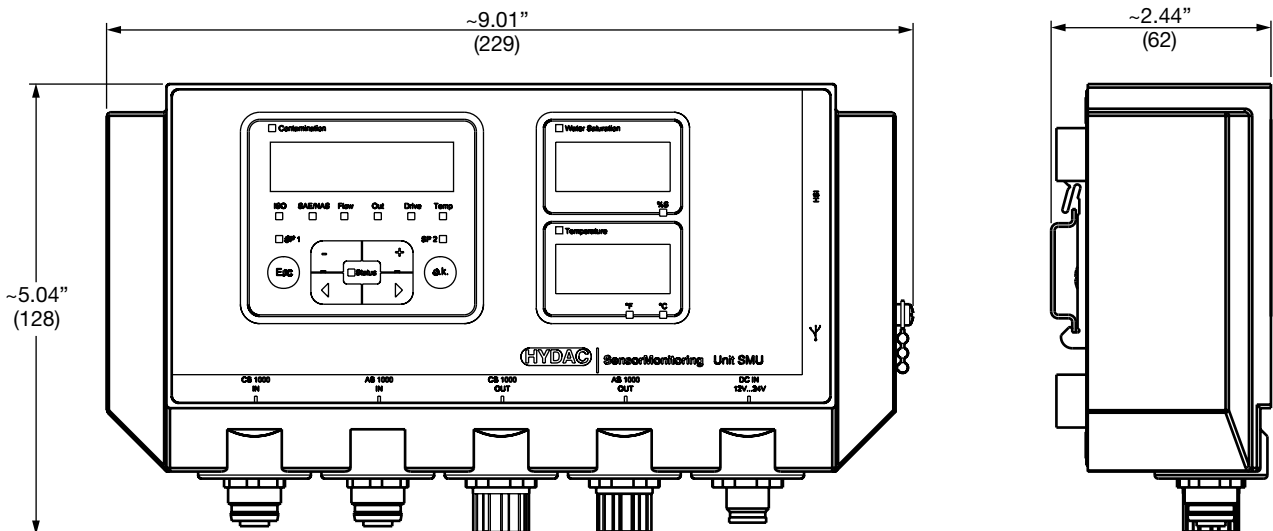

Dimensions are for general information only, all critical dimensions should be verified by requesting a certified print.

CONTAMINATION MONITORS

FMS Series

Fluid Monitoring System



Description

The Fluid Monitoring System FMS combines HYDAC's Condition Monitoring Products Contamination Sensor CS1000 and Aqua Sensor AS1000 and the Sensor Monitoring Unit in one system.

The FMS is used as a robust and stationary system for online measurement of solid particle contamination and water content in hydraulic and lubricant fluids (e.g. for the detection of leakages).

The SMU shows the cleanliness class and the fluid temperature as well as the relative humidity. These values are passed on via the signal output for further processing.

The FMS features all of the requisite connectors / adapters, enabling it to be easily connected to existing hydraulic circuits.

Depending on the version, the FMS is suitable for bypass flow and pressure circuits:

FMS-FMM-O... = 87 – 217.6 psi (6 – 15 bar)

FMS-FMM-P... = 217.6 – 4351 psi (15 – 300 bar)

Advantages

- Cost-effective solution
- Early warning of critical machine states
- Continuous fluid monitoring
- Condition-based maintenance planning

Caution!

The FMS is only to be used with mineral oils or mineral oil-based raffinates.

Hydraulic Schematic

FMS-FMM-O

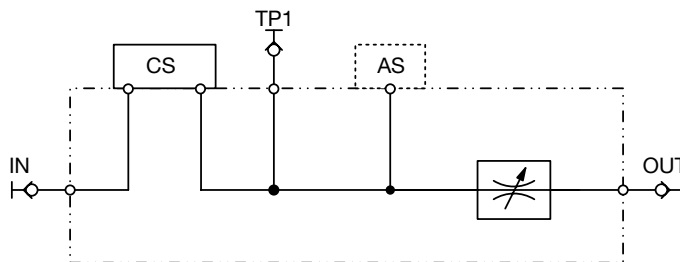

FMS-FMM-P

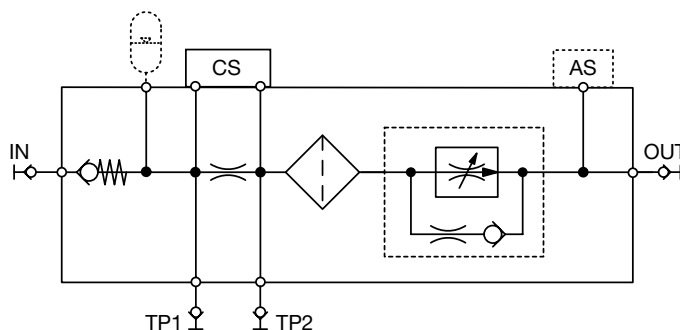

Technical Specifications

FMS-FMM-O...	
Operating pressure	87 to 217 psi (6 to 15 bar)
Minimal differential pressure	14.5 psid (1 bar), recommended >= 43.5 psid (3 bar)
Connectors (IN / OUT)	Test point type 1604 or thread G 1/4 according ISO 228
Sealing material	FPM
Permissible viscosity range	37-1623 SUS (1 to 350 mm ² /s)
Fluid temperature range	32° to 185° F (0° to 85° C)
Ambient temperature range	-22° to 176° F (-30° to 80° C)
Storage temperature range	-40° to 176° F (-40° to 80° C)
Weight	29 lbs (~13 kg)
FMS-FMM-P...	
Operating pressure without accumulator with accumulator	217 to 4350 psi (15 to 300 bar) 217 to 3625 psi (15 to 250 bar)
Differential pressure	> 87 psi (15 bar)
Connectors (IN / OUT)	Test point type 1604 / thread G ¹ / ₄ according ISO 228
Sealing material	FPM
Permissible viscosity range	37-4635 SUS (1 to 1000 mm ² /s)
Fluid temperature range	32° to 185° F (0° to 85° C)
Ambient temperature range	-22° to 176° F (-30° to 80° C)
Storage temperature range	-40° to 176° F (-40° to 80° C)
Weight	44 lbs (~20 kg)

Model Code

FMS - FMM-P - CS - AS - SMU12 - 01 / - 000

Type

FMS = Fluid Monitoring System

Hydraulic application

FMM-O = Offline, (bypass flow circulation 87 psi) < 15 bar
 FMM-P = Pressure Line, (pressure circuit 87 psi) > 15 bar

ContaminationSensor

CS = CS 1000 *
 Z(CS) = Prepared for CS 1000

AquaSensor

AS = AS 1000
 Z(AS) = Prepared for AS 1000

SensorMonitoring Unit

SMU12 = SMU 1200

Sensor combination

01 = FMM-O-M-0-CS1310-A-AS-0-0-0-0-000 SMU1260-TU-00/-000
 02 = FMM-P-L-0-CS1310-A-AS-0-1-0-0-000 SMU1260-TU-00/-000

Customer modification number

000 = Customer modification number

*Type defined in sensor combination number

Items supplied

- 1 FluidMonitoring System FMS
- 1 Power supply connection cable, L = 16.4' (5m)

Technical Documentation, consists of:

- 1 Installation and Maintenance Instructions FMS
- 1 Operating and Maintenance Instructions SMU 1200
- 1 Operating and Maintenance Instructions AS 1000
- 1 Calibration certificate of the CS 1000

Upon receiving the FMS check it for any damage in transit. Do not put the FMS into operation unless it is in perfect condition. Report any damages in transit to the transport company or the responsible agent immediately. Do not put the unit into operation.

Dimensions

FMS-FMM-O

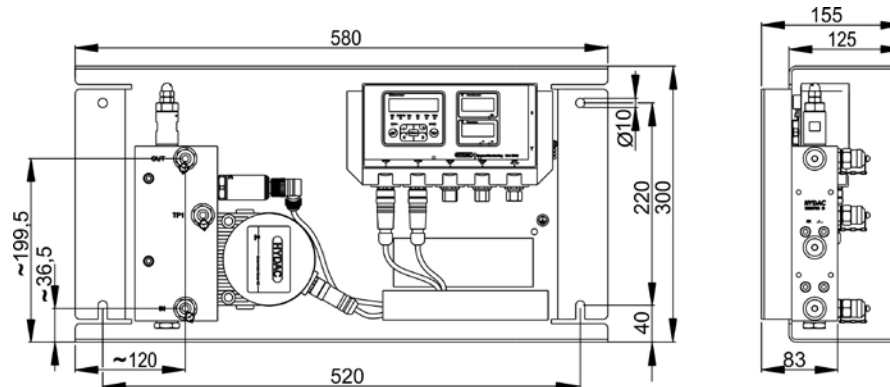

FMS-FMM-P

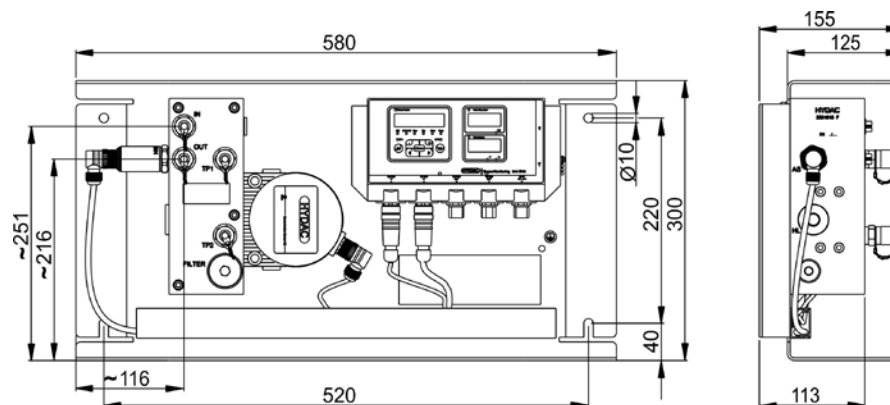

Dimensions are for general information only, all critical dimensions should be verified by requesting a certified print.

CONTAMINATION MONITORS

CTU 1000 Series

Contamination Test Unit



Description

The HYDAC Cleanliness Test Unit CTU 1000 is designed to determine the technical cleanliness especially present on minor contaminated components.

The CTU 1000 was developed due to increased demand for system cleanliness and for monitoring and optimizing the cleanliness, of smaller components during production, storage and system assembly.

By determining the type, size and quantity of the contamination, quality standards can be checked and documented and the necessary steps towards optimization can be taken.

Applications

- Automotive suppliers
- Gear box builders
- Engine builders
- Suppliers of hydraulic and lubrication components

Benefits to You

- Cost reduction through lower production failure rates
- Identification and elimination of weak process steps
- Optimization of both internal and external handling processes
- Establishing of cleanliness standards both internal and external
- Documentation of component cleanliness
- Survey of fluid cleanliness and filtration concepts

Technical Specifications

Overall dimensions (height x width x length)	CTU10xx = 70.9"x38.8"x32.9" (1800mm x 985mm x 835mm) CTU12xx = 70.9"x35.8"x44.9" (1800mm x 910mm x 1140mm)
Weight	CTU10xx approx. 595 lbs (270 kg) approx. 640 lbs (290 kg) (with ultrasonic) CTU12xx approx. 685 lbs (310 kg)
Type	Mobile (mounted on castors)
Power Consumption	600 W (800 W with ultrasonic)
Ambient Temperature	59° to 82°F (15° to 28°C)
Cleanroom Module	
Material of cleanroom	polished stainless steel
Filling with analysis fluid	via analysis cabinet
Control	PC controlled with user-friendly software, rinse options and rinsing volume programmable
Reservoir and Filtration Module	
Membrane holder	for 1.85" to 1.97" filter membranes (Ø 47 to 50 mm)
Vacuum strainer	for quicker filtration of the analysis fluid
Diffuser	Distribution of analysis fluid on the membrane
Operating pressure	-12 to 87 psi (-0.8 to 6 bar)
Analysis fluid reservoir	2x 5.2 gal (20 l) (1x reservoir, 1x suction reservoir)
Reservoir change-over	automatic
Filtration of analysis fluid	Fine filtration according ISO 4406 min. ISO 12/9
Filter size, filtration rating	2x LF BN/HC 60, 3 µm (1xx0 series) 2x MRF-1-E/1, 1µm (1xx1 series)
Integrated drip tray	6.6 gal (25 liter) with drainage
Services to be provided by operator*	
Compressed air	Air Filtered (min. 5µm) and dry compressed air, max. 1741 psi (6 bar) Air flow rate: 15.8 gpm (60 lpm), Supply connection: DN 7.2
Power Supply	according to order

*not supplied

The information in this catalog relates to the operating conditions and applications described. For applications or operating conditions not described, please contact the relevant technical department. Subject to technical modifications.

Model Code

CTU 1 0 3 0 - K - Z - Z

Series

CTU = Contamination Test Unit

Model

1 = Analysis cabinet (clean room)

Installation Size

0 = Dimensions analysis cabinet: 11.8"x30.2"x14.4" (300mm x 768mm x 365mm) (effective height x width x length)

2 = Dimensions analysis cabinet: 18.1"x30.2"x25.6" (460mm x 768mm x 650mm) (effective height x width x length)

Analysis

3 = Version 2011 with ConTes software, 1um filtration and automatic pressure control

4 = Version 2014 with interior air extractor for clean box, quick coupling valves, compression door lock, ball valve (2/3 way) in front of membrane holder and for CTU12xx series - swivel arm for monitor

Analysis Fluid

0 = Solvent A III Class (Flashpoint > 140°F (60°C), lower explosion limit > 0.6 Vol.%)

1 = Water with surfactants, admissible pH-range 6 to 10, no deionized / demineralized water

Supply Voltage

K = 120 V AC / 60Hz / 1 Phase USA / CDN

M = 230 V AC / 50Hz / 1 Phase Europe

N = 240 V AC / 50Hz / 1 Phase UK

Extraction Process

Z = Rinsing (medium pressure)

U = Rinsing (medium pressure) plus ultrasonic

Supplementary Details

Z = standard

R = external rinsing connections 0.24" (Ø 6mm), between the hand holes

Note: Analyzing Fluid not supplied with unit - G60 Analyzing Fluid, 30L; PN 03205511

Dimensions CTU10XX

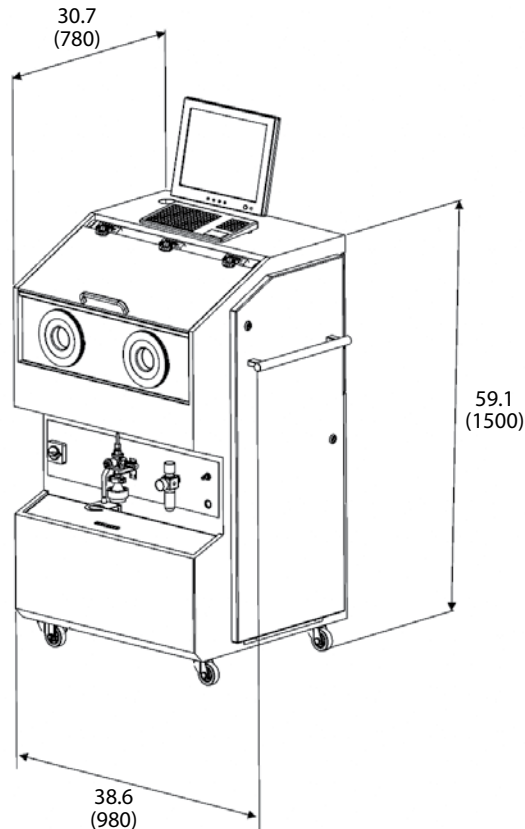

CTU12XX

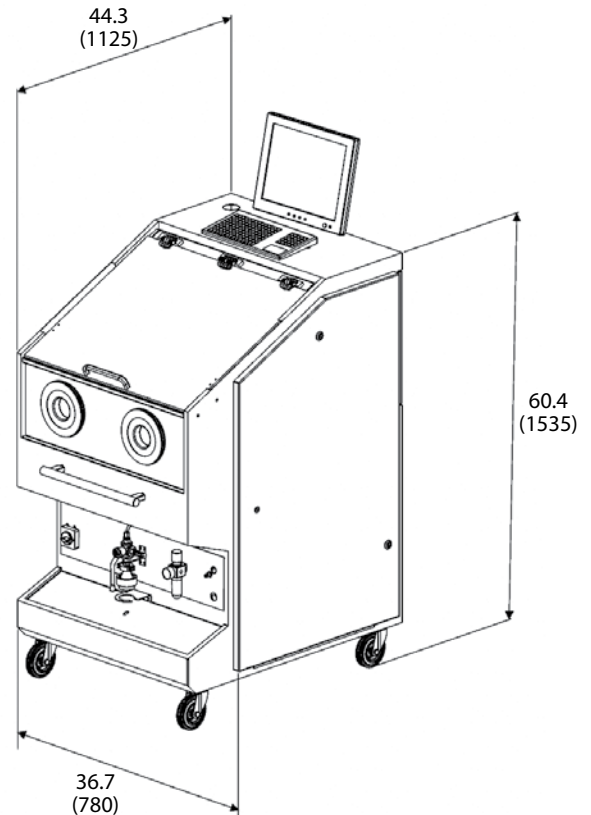

Dimensions are inches (millimeters) and for general information only, all critical dimensions should be verified by requesting a certified print.

CONTAMINATION MONITORS

CTM-SC Series

Contamination Test Module – Supply & Control



Description

The Contamination Test Module CTM is a modular system designed to analyze the technical cleanliness of components. Solid contamination is washed off the surface of the component, samples are taken from the fluid and are subsequently analyzed using membranes.

The Contamination Test Module CTM-SC is the central module of the CTM series. It serves as the fluid supply and the control of the entire extraction processes and contains the graphical user interface.

Applications

- Automotive and supplier industry
- Gear and engine builders
- Mobile hydraulics
- Production of hydraulic / lubrication system components
- Aircraft industry

Benefits to You

- Reduction in costs as a result of fewer production failures
- Identification and elimination of weak process steps
- Reduction in start-up breakdowns
- Optimization of internal and external processes
- Documentation of the technical cleanliness of components

Special Features

- Analysis fluid can be pulsed if required
- Adjustment of compressed air
- Filling and drainage connection
- Control and monitoring of CTM-E modules
- Automatic pressure setting using software
- User-programmable extraction procedure

Technical Specifications

Overall dimensions <i>(height x width x length)</i>	5.9'x2.5'x2.6' (1.8m x 0.9m x 0.8m)
Housing material	S235JR powder-coated
Coupling connection	CPC coupling
Ambient Temperature	59° to 82°F (15° to 28°C)
Weight	≈ 551 lbs (250 kg) <i>(empty)</i>
Reservoir, test fluid	2 x 5.3 gal (20 l) <i>(1 x reservoir, 1 x collection tank)</i>
Reservoir switch-over	Automatic
Filtration of analysis fluid	Fine filtration to ISO4406 min. 12/9
Filter size	2x MRF-1-E/1, 1 µm
Drip tray, integral	6.6 gal (25 l) with drain
Compressed air supply	Nipple DN 7.2
Compressed air supply <i>(provided by customer)</i>	Maximum 87 psi (6 bar), Air flow rate: 15.9 gpm (60 lpm) Dry and pre-filtered to 5 µm
Electrical Data	
Supply voltage	according to order
Power consumption	600 Watt; 800 Watt with ultrasound
Protection class to DIN 40050	IP 54

The information in this catalog relates to the operating conditions and applications described. For applications or operating conditions not described, please contact the relevant technical department. Subject to technical modifications.

Model Code

CTM SC 100 0 - M

Series

CTM = Contamination Test Module

Model

SC = Supply and control

Series

100 = Standard

Analysis Fluid

0 = Solvent A III Class (*Flashpoint > 140°F (60°C), lower explosion limit > 0.6 Vol.%*)

1 = Water with surfactants, admissible pH-range 6 to 10, no deionized / demineralized water

Supply Voltage

K = 120 V AC / 60Hz / 1 Phase USA / CDN

M = 230 V AC / 50Hz / 1 Phase Europe

N = 240 V AC / 50Hz / 1 Phase UK

Items supplied

- CTM-SC
 - incl. monitor and monitor bracket
 - PC with Windows operating system
 - PLC
 - Keyboard with touchpad
 - Foot switch
 - CTM-SC Software
- Operating and maintenance instructions

Dimensions

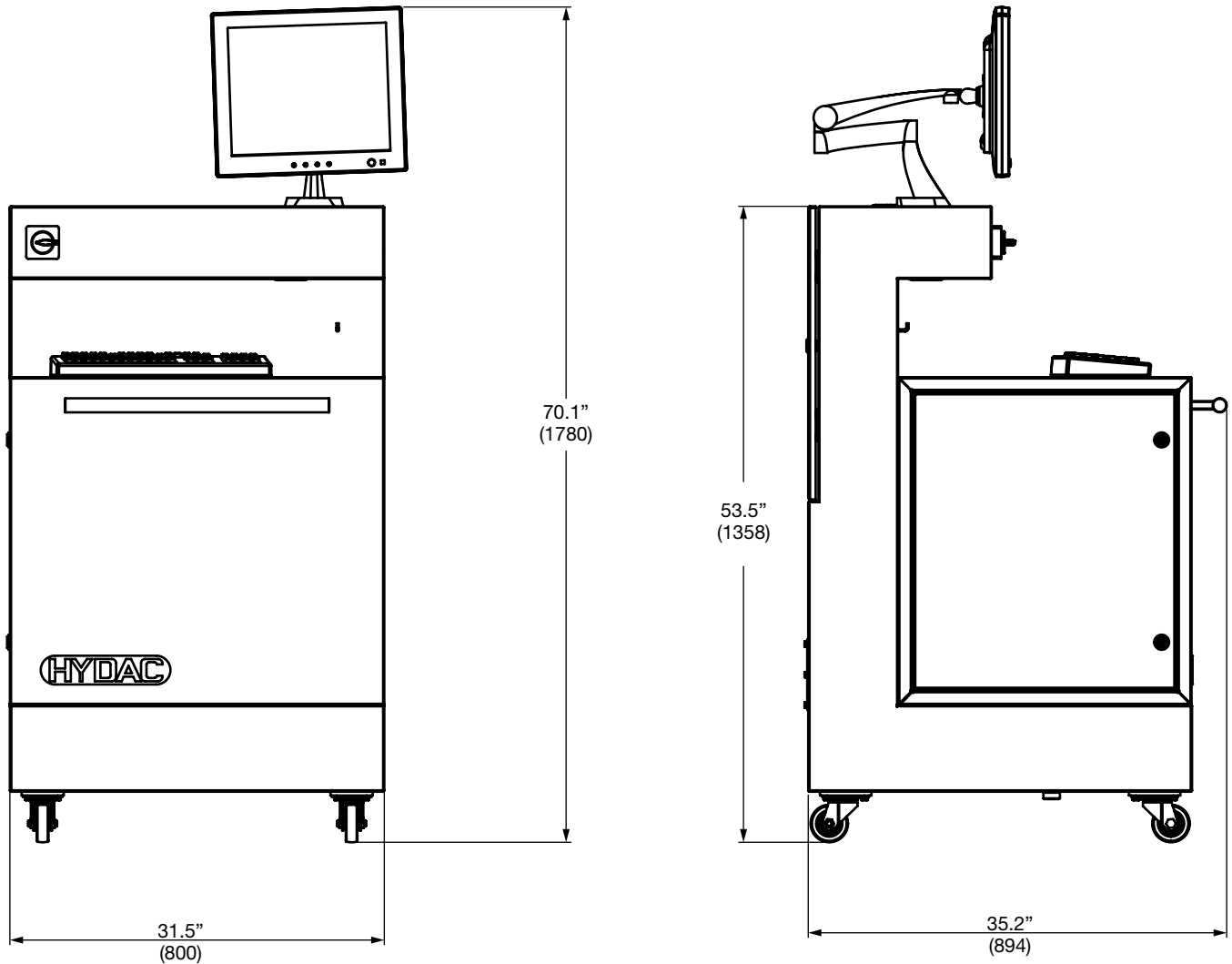

Dimensions are inches (mm) and for general information only, all critical dimensions should be verified by requesting a certified print.

CONTAMINATION MONITORS

CTM-EB Series

Contamination Test Module – Extraction Box



Description

The Contamination Test Module CTM is a module system designed to analyze the technical cleanliness of components. Particle contamination is removed from the surface of the component, samples are taken from the washing fluid and are subsequently analyzed using membranes.

The extraction module CTM-EB is designed for spray extraction in conjunction with the CTM-SC.

Applications

- Automotive and supplier industry
- Transmission and engine builders
- Mobile hydraulics
- Manufacture of hydraulic and lubrication system components
- Aircraft Industry

Advantages

- Reduction in costs as a result of fewer production failures
- Identification and elimination of weak process steps
- Reduction in start-up breakdowns
- Optimization of internal and external processes
- Documentation of the technical cleanliness of components

Technical Specifications

Overall dimensions (height x width x length)	EB1200: 59" ... max. 68.9"x47.2"x35.4" (min. 1.50 ... max. 1.75 x 1.20 x 0.90 m) EB1400: 59" ... max. 68.9"x72.8"x35.4" (min. 1.50 ... max. 1.75 x 1.85 x 0.90 m) EB1600: 61" ... max. 70.9"x43.3"x35.4" (min. 1.55 ... max. 1.80 x 1.10 x 0.90 m) EB2000: 66.9" ... max. 76.8"x55.1"x43.3" (min. 1.70 ... max. 1.95 x 1.40 x 1.10 m)
Housing material	S235JR powder-coated
Ambient Temperature	59° to 82°F (15° to 28°C)
Working height adjustment	electrical
Weight when empty	CTM-EB 12xx: 440lbs. (~200 kg) CTM-EB 14xx: 529lbs. (~240 kg) CTM-EB 16xx: 485lbs. (~220 kg) CTM-EB 18xx: 485lbs. (~220 kg) CTM-EB 20xx: 573lbs. (~260 kg) CTM-EB 46xx: 617lbs. (~280 kg)
Coupling connection	CPC Coupling
Filtration of analysis fluid	Fine filtration to ISO4406 min. ISO 12/9
Filter size	3x MRF1-E/1, 1 µm
Extraction Cabinet (clean box)	
Material of Clean Box	Polished stainless steel 1.4301
Maximum load capacity	EB1200: 69 lb (31.5 kg)* EB1210: 220 lb (100 kg) EB1400: 220 lb (100 kg)* EB1410: 331 lb (150 kg) EB1600: 220 lb (100 kg)* EB1610: 331 lb (150 kg) EB1800: 331 lb (150 kg)* EB1810: 331 lb (150 kg) EB2000: 220 lb (100 kg)* EB2010: 331 lb (150 kg) EB4600: 364 lb (165 kg)* EB4610: 331 lb (150 kg) <i>*for evenly distributed load, no point load</i>
Opening of cover	electrical
Membrane holder	For ø1.85" (ø47 mm) filter membranes
Electrical Data	
Supply voltage	according to order
Power consumption	400 Watt
Protection class to DIN 40050	IP 54

The information in this catalog relates to the operating conditions and applications described. For applications or operating conditions not described, please contact the relevant technical department. Subject to technical modifications.

Model Code

CTM EB 12 0 0 - M - Z - Z / -

Series

CTM = Contamination Test Module

Model

EB = Extraction Box

Dimensions of analysis cabinet (average height x width x depth)

12 = 18.5" (470 mm) x 30.3" (770 mm) x 25.6" (650 mm)
 14 = 15.7" (400 mm) x 55.1" (1400 mm) x 15.7" (400 mm)
 16 = 28.0" (710 mm) x 27.6" (700 mm) x 24.4" (620 mm)
 20 = 33.9" (860 mm) x 35.4" (900 mm) x 35.4" (900 mm)
 46 = 22.4" (570 mm) x 69.7" (1770 mm) x 25.6" (650 mm)

Execution of load

0 = standard
 1 = heavy

Analysis Fluid

0 = Solvent A III Class (Flashpoint > 60°C, lower explosion limit > 0.6 Vol.%)
 1 = Water with surfactants, admissible pH-range 6 to 10, no deionized / demineralized water

Supply Voltage

K = 120 V AC / 60Hz / 1 Phase USA / CDN
 M = 230 V AC / 50Hz / 1 Phase Europe
 N = 240 V AC / 50Hz / 1 Phase UK

Extraction method

Z = spray, medium pressure

Supplementary details

Z = standard

Modifications

- = without modifications

Items supplied

- CTM-EB
- Operating and maintenance instructions

Accessory - CTM-EB Disk

- 1200 = Part. No. 3439102
- 2000 = Part. No. 3422445

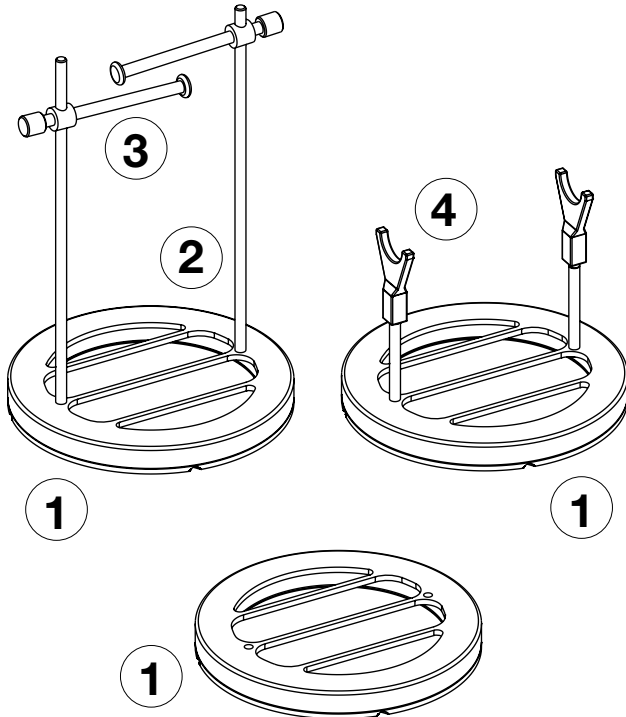

Item	Designation
1	Disk
2	Guide rod (available in different lengths)
3	Clamping rod (available in different lengths)
-	Y-shaped Bracket

Accessory - Angled Bracket

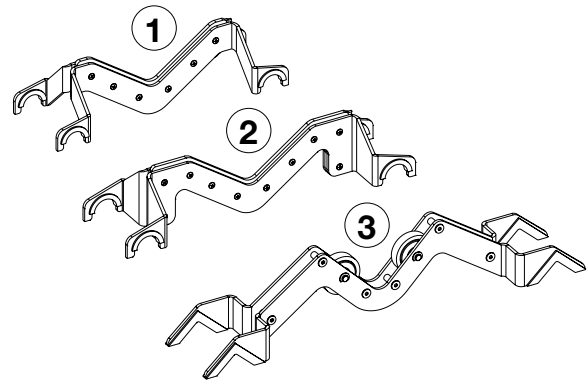

Item	Designation
1	Angled bracket – light duty
2	Angled bracket – medium duty
3	Angled bracket – heavy duty

Accessory - Polished Rack

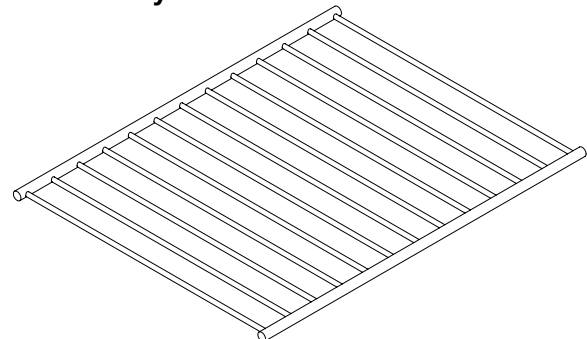

Supplied with the CTM-EB 1200.

CONTAMINATION MONITORS

Dimensions
CTM-EB overall

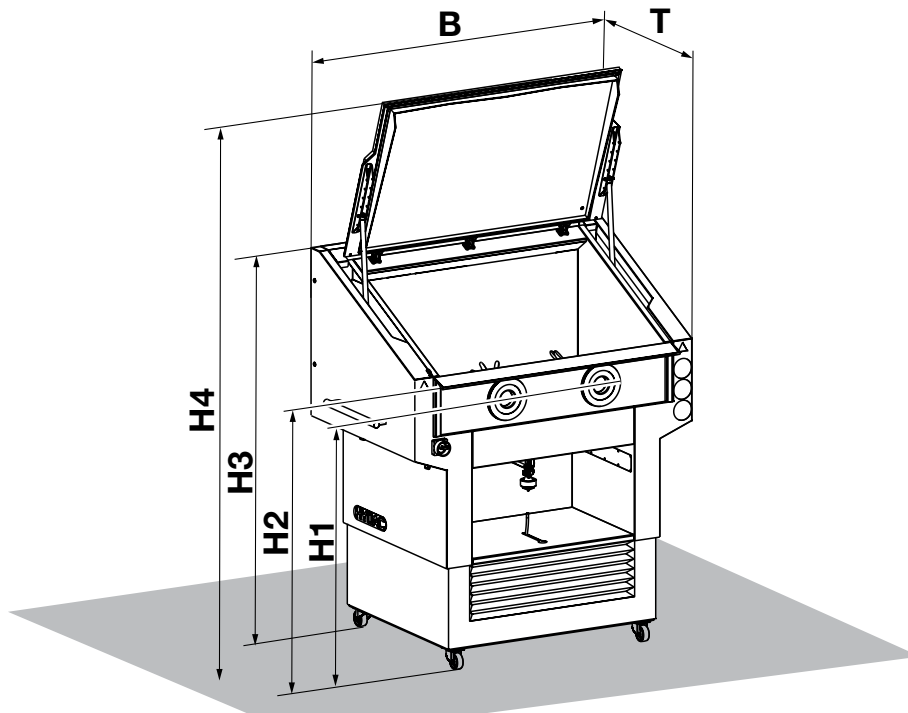

CTM-EB	B	T	H1	H2	H3	H4
12xx	43.7" (1110)	36.2" (920)	38.8" to 48.6" (985 to 1235)	47.0" to 54.9" (1195 to 1395)	59.5" to 69.3" (1510 to 1760)	84.6" to 94.5" (2150 to 2400)
14xx	72.0" (1830)	36.2" (920)	37.6" to 47.4" (955 to 1205)	45.0" to 54.9" (1145 to 1395)	59.5" to 69.3" (1510 to 1760)	70.9" to 80.7" (1800 to 2050)
16xx	43.7" (1110)	36.2" (920)	40.2" to 50.0" (1020 to 1270)	50.0" to 59.8" (1270 to 1520)	61.4" to 71.3" (1560 to 1810)	84.6" to 94.5" (2150 to 2400)
18xx	64.2" (1630)	42.1" (1070)	40.2" to 50.0" (1020 to 1270)	45.3" to 55.1" (1150 to 1400)	62.6" to 72.4" (1590 to 1840)	93.5" to 103.3" (2375 to 2625)
20xx	55.1" (1400)	45.3" (1150)	39.4" to 52.8" (1000 to 1340)	48.6" to 58.5" (1235 to 1485)	42.5" to 76.0" (1080 to 1930)	96.5" to 106.3" (2450 to 2700)
46xx	90.6" (2300)	36.2" (920)	39.0" to 48.8" (990 to 1240)	46.5" to 56.3" (1180 to 1430)	59.0" to 69.0" (1500 to 1750)	86.6" to 96.5" (2200 to 2450)

Dimensions of Extraction Cabinet (Clean Box)

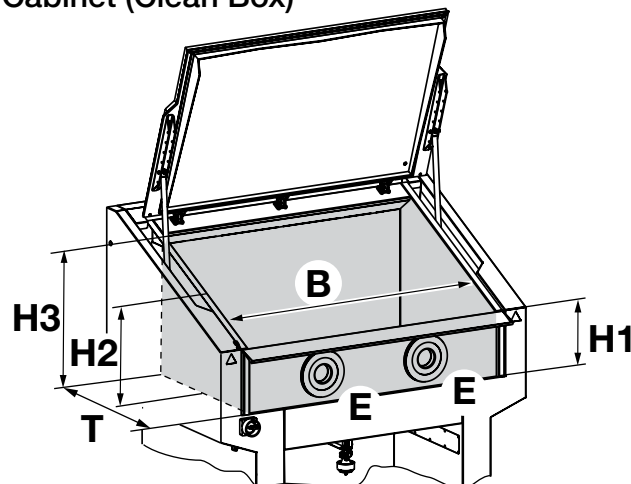

CTM-EB	B	T	H1	H2	H3	E
12xx	30.3" (770)	25.6" (650)	11.0" (280)	18.5" (470)	21.5" (545)	2 x \varnothing 7.1" (\varnothing 180)
14xx	55.1" (1400)	15.7" (400)	11.0" (280)	15.7" (400)	17.1" (435)	3 x \varnothing 7.1" (\varnothing 180)
16xx	26.4" (670)	24.4" (620)	23.4" (595)	27.6" (700)	30.1" (765)	2 x \varnothing 9.0" (\varnothing 230)
18xx	47.2" (1200)	30.7" (780)	10.6" (270)	17.7" (450)	23.8" (605)	2 x \varnothing 7.1" (\varnothing 180)
20xx	35.4" (900)	35.2" (895)	26.8" (680)	31.5" (800)	37.8" (960)	2 x \varnothing 9.0" (\varnothing 230)
46xx	69.7" (1770)	25.6" (650)	14.2" (360)	22.4" (570)	24.2" (615)	4 x \varnothing 9.0" (\varnothing 230)

Dimensions are inches (mm) and for general information only, all critical dimensions should be verified by requesting a certified print.

Dimensions CTM-EB 1200

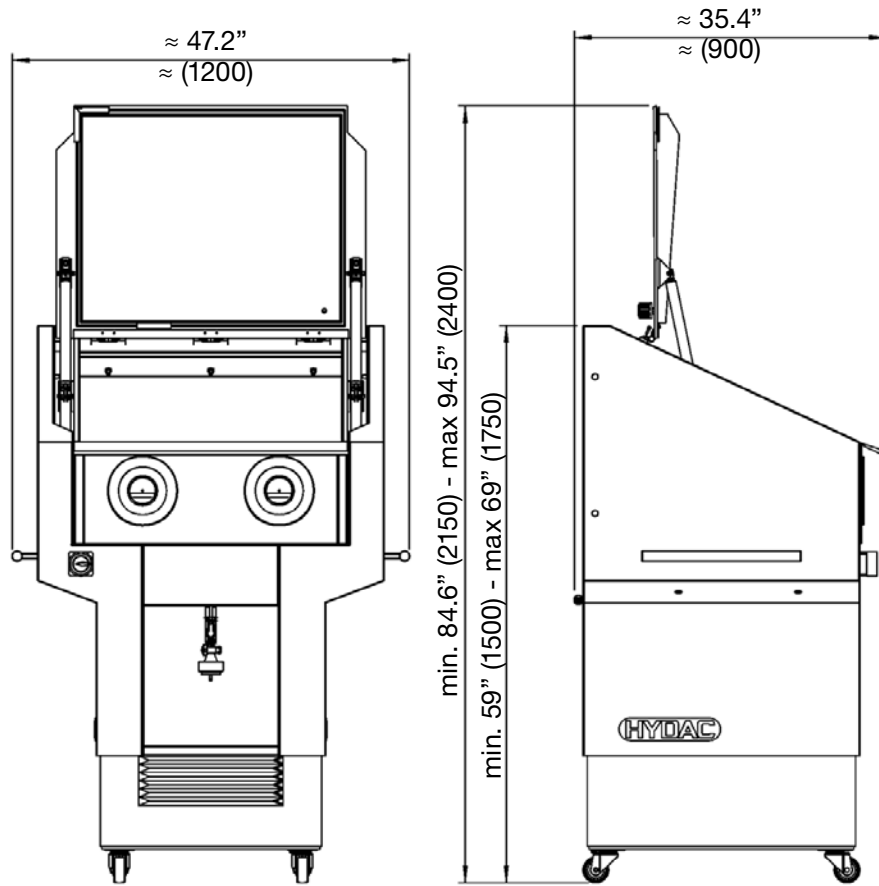

CTM-EB 1400

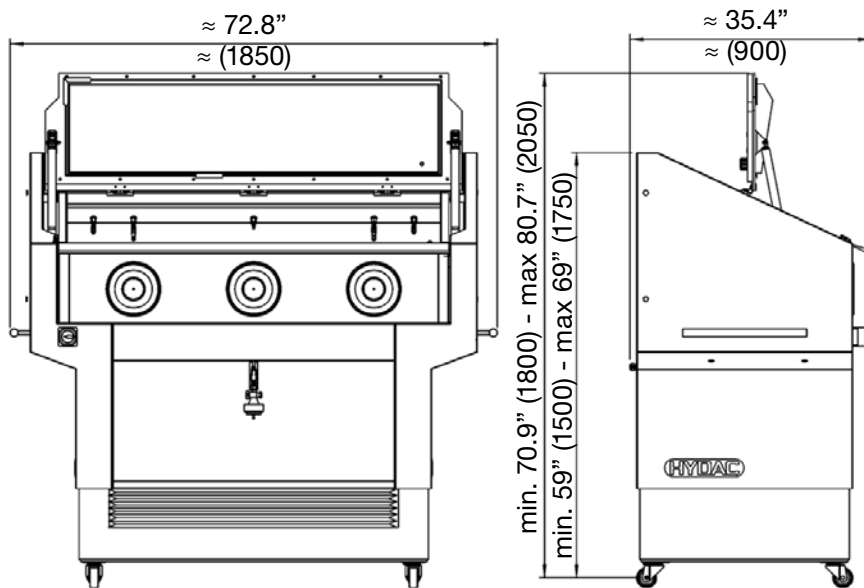

Dimensions are inches (mm) and for general information only, all critical dimensions should be verified by requesting a certified print.

CONTAMINATION MONITORS

Dimensions CTM-EB 1600

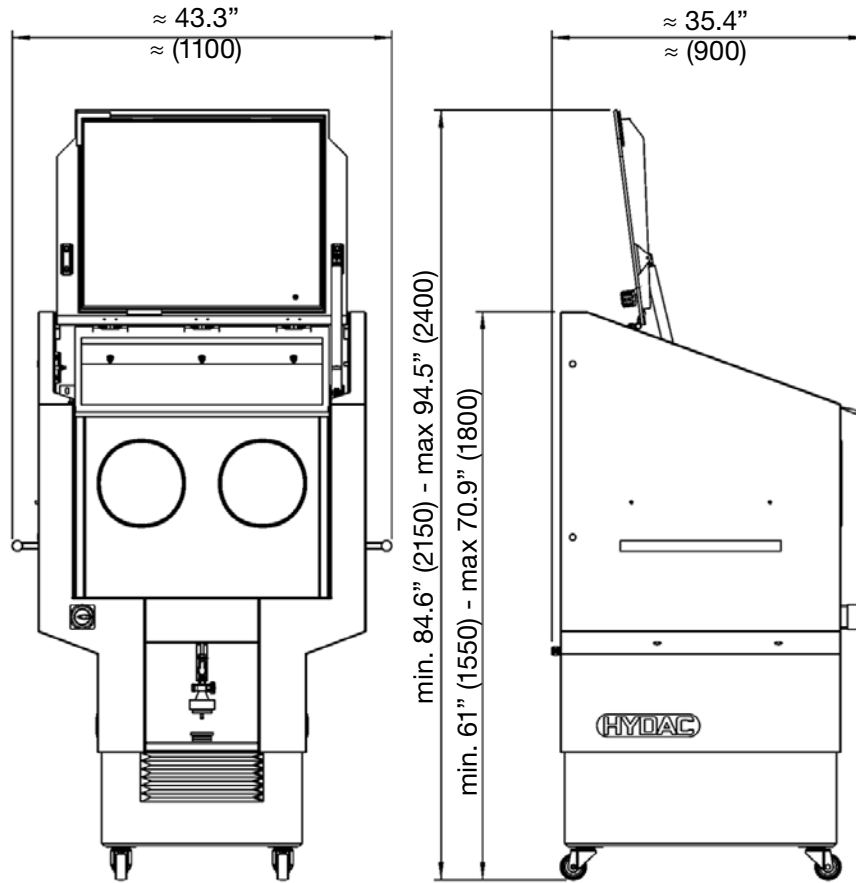

CTM-EB 2000

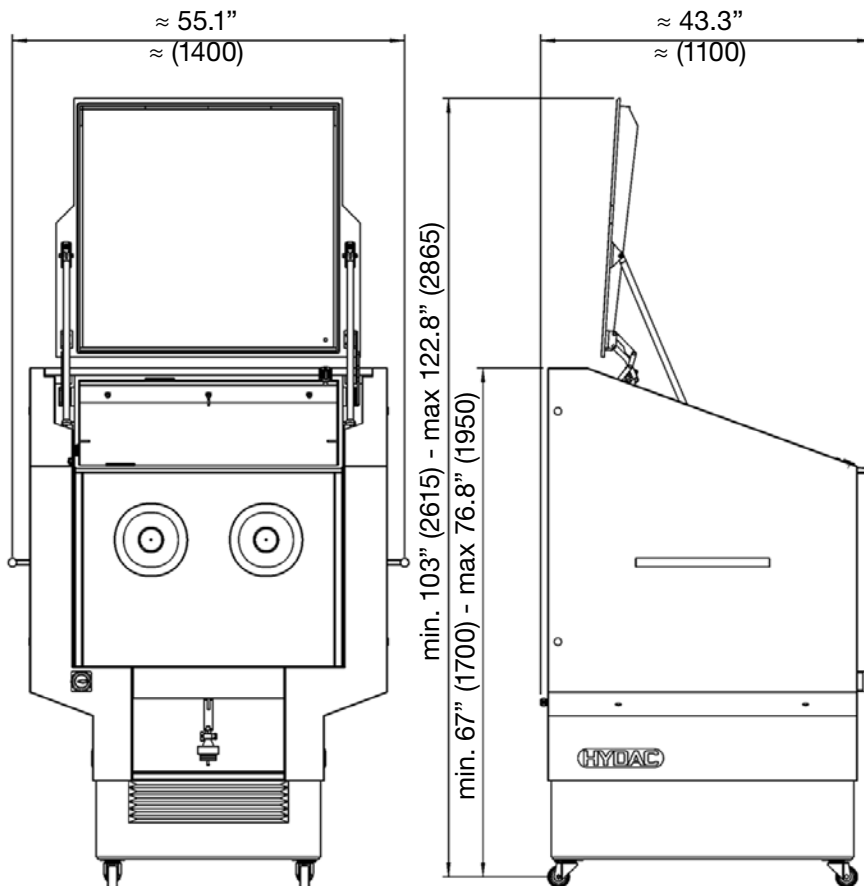

Dimensions are inches (mm) and for general information only, all critical dimensions should be verified by requesting a certified print.

CONTAMINATION MONITORS

MM Series

Measuring Microscopes



Description

This microscope is designed specifically to be used for measuring contamination particles in oil samples on filter membranes. All models include coarse and fine focusing adjustments, as well as both X and Y directional slide table adjustments to make focusing and positioning the subject simple, even at maximum magnification.

There is a rotating lens holder with 3 achromatic objective lenses with magnifications of 4x, 10x, and 20x. The micrometer eyepiece provides an additional 10x magnification resulting in 40x, 100x, and 200x magnifications. The measuring scale on the eyepiece has a scale division of 1 mm in 100 parts, allowing measurement of particles at all three magnifications.

These units come with an integrated plug-in light source that provides sufficient illumination, even at maximum magnification.

The optional CCD digital camera attaches to the eyepiece and transfers images to a PC via a USB connection, making it easy to capture and transmit images from the microscope.

Ordering Information

MM-S5-P	Standard eyepiece 110 VAC 60 Hz powered light source
MM-S5-P-U	Standard eyepiece 110 VAC 60 Hz powered light source CCD camera with LPT-1 port for connection to laptop or PC
MM-KKE-P-C-U	Triocular eyepiece 110 VAC 60 Hz external cold light illumination CCD camera with LPT-1 port for connection to laptop or PC

Technical Specifications

MM-S5-P, MM-S5-P-U, & MM-KKE-P-C-U	
Huygens Eyepiece	10 x M
Achromatic Lens	4x, 10x, 20x
Magnification	40x, 100x, 200x
Supply Voltage	110 V 60 Hz
MM-S5-P-U & MM-KKE-P-C-U (only)	
Image Digitization	CCD-Camera
Video System	PAL color system
Resolution	horiz. 460 lines, vert. 400 lines
Image Processing	Video capture unit
PC interface	LPT 1 port
System Requirements	min. Pentium 100 Mhz., Windows 95

FAS Series Fluid Analysis Service

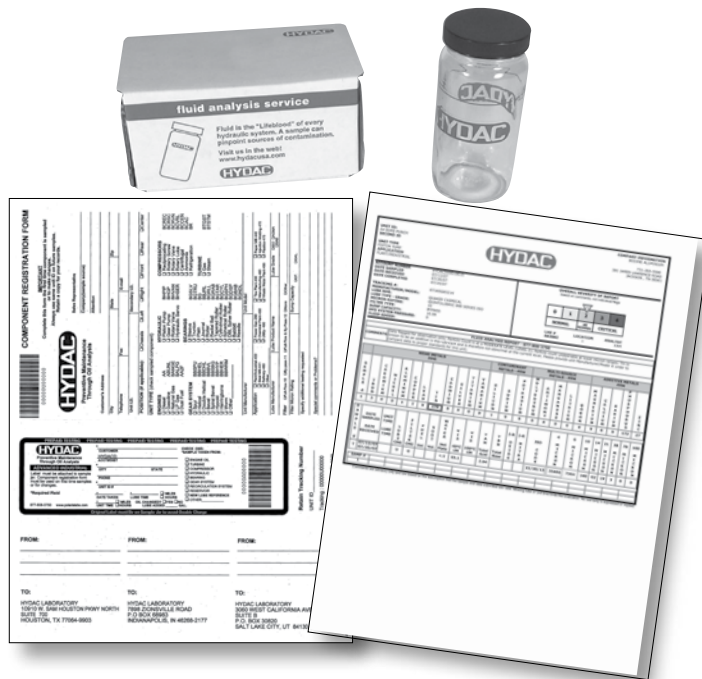

Additional Oil Analysis Tests are available; contact factory for information

Premium Oil Sample Testing

Test Kit part number: 02702060 (includes a box of 10 sample bottle kits)

Oil sample analysis for standard mineral hydraulic and lube oil includes the following tests:

- Spectrometals by ICP (24 Metals including Wear, Contaminant, Additive & Multi-Source) – D5185
- Viscosity @ 104°F (40°C) (ASTM D445)
- Water % by Crackle (Karl Fischer if Crackle is Positive)
- Total Acid Number – TAN (ASTM D664)
- Particle Count (as per ISO4406:1999 - 3 digit ISO code 4, 6, 14)

Test Kit part number: 02095151 (includes a box of 10 sample bottle kits), the same as the above analysis as well as a photomicrograph

Water Glycol Sample Testing:

Test Kit part number: 02702057 (includes a box of 10 sample bottle kits)

This kit includes specific analysis parameters for the water to oil ratio of the Glycol. Karl Fischer Water is done and pH is tested instead of TAN. If the water concentration is tested out of specification to the identified lubricant, the lab will give the current concentration level and then make a recommendation for the acceptable water concentration percentage range for the stated lubricant. The tests included are as follows:

- Spectrometals (24 Metals by ICP including Wear, Contaminant, Additive & Multi-Source) – D5185
- Viscosity @ 104°F (40°C) – ASTM D445
- Water by Karl Fischer in PPM – ASTM D1744
- pH (If a Standard Mineral Oil is Identified, then TAN is done)
- ISO Particle Count (as per ISO4406:1999 - 3 digit ISO code 4, 6, 14)

Oil Analysis Reports:

Each Fluid Analysis Kit contains:

- Clean Sample Bottle
- Component Registration Form (CRF)
- Packaging for mailing sample
- Prepaid Fluid Analysis Service

Choice of three ISO 17025 A2LA accredited laboratories to send the samples. Addresses are included on the Component Registration Form

- All locations are within 48 hours ground transit from nearly anywhere in the continental United States
- Results returned within 24-48 hours after lab receipt of the test samples
- Fast email or fax notification of high severity results

A Component Registration Form (CRF) is included with each sample bottle kit, but it only needs to be filled-out the first time each piece of equipment is sampled or to make changes. After the initial sample, the CRF information is stored under the Unit ID #.

Sample results will be e-mailed to the e-mail address supplied on the CRF. Additionally, a Username and Password will be emailed to each report recipient who provides an e-mail address on the Component Registration Form (CRF). This feature allows multiple users to view the reports simultaneously. The Username and Password provides the recipient with access to www.oilreports.com where a personal internet account has been set-up. From this site, the full sample report with the capability of graphing and trending analysis is available online as well as the complete testing history is securely stored.

HYDAC Canada Fluid Analysis Services *(Canada Customers Only)*

Contamination Analysis

Test Kit Part Number: 02552392 (single); 02552390 (pack of 10)

This kit identifies contamination before it hampers production and shortens component life and includes:

- Particle Count
- Water Content
- Viscosity
- Patch Test/Photo

Total Conditioning Analysis Kit

Test Kit Part Number: 02552393 (single); 02552391 (pack of 10)

Includes all the above tests PLUS it determines: additive; wear metal; contaminant and oxidation levels. Tests included in this kit are:

- Particle Count
- Water Content
- Total Acid Number
- Viscosity
- Patch Test/Photo
- Spectrographic Analysis

Water Glycol Analysis Kit

Test Kit Part Number: 02550327

This kit is designed exclusively for water glycol systems. Contamination, water content and viscosity are monitored. Tests included:

- Water Content
- Viscosity
- Patch Test/Photo
- Estimated ISO 4406 cleanliness code

CONTAMINATION MONITORS

FASH Series

Fluid Analysis Sets



Features and Benefits

- Compatible with hydraulic and lube oils
- Provides results on site in a matter of minutes
- Determines solid contamination levels in hydraulic systems
- Includes all necessary equipment in a single lightweight case

Applications

- Perform quick on-site determination of contamination levels of solid particulate
- Supplement on-site laboratories
- Use as a tool to demonstrate need for improved filtration

Applicable standards

- ISO 4405 / 4406 / 4407
- Gravimetric methods for determining the amount of contamination in hydraulic fluids.

Description

The Fluid Analysis Set from HYDAC provides the necessary tools to determine levels of solid particulate contamination present in a particular fluid sample. Using the vacuum pump contained in the kit, the fluid sample is drawn through a membrane patch. The residual dirt left on the patch is viewed under a microscope and compared to photos of known contamination levels in the HYDAC Contamination Handbook (*included*) for a visual assessment.

Ordering Information

Part Number: 02086847

Items Included in the Kit

- Molded Carry Case
- Microscope 100x
- Vampire Pump
- Funnel
- Forceps
- Rubber Tubing Hose-1/4"
- Plastic Petri Dish
- 38mm Sample Bottles 4 oz
- Pen Light for Microscope
- (0.8) & (5.0) Millipore Patches
- Solvent Filters
- Syringes 30ml

C Diagnostic Monitoring

These units are designed for data capturing simple measurements (*pressure, temperature, and flow rate*) in hydraulic and pneumatic systems. Typical applications extend primarily to maintenance and servicing, troubleshooting and test stands, as well as, quality inspections.

HMG 2500 Series

Portable Data Recorder



3.5" colour display Up to 4 sensors can be connected Automatic sensor recognition

Description

The HMG 2500 is an impressive, top performance portable measuring and data logging device.

Automated setting procedures, a simple, self-explanatory operator guide and many comprehensive functions ensure the operator is able to carry out a wide range of measuring tasks within a very short time.

This makes the HMG 2500 an ideal companion for employees in maintenance, commissioning and service.

The device is designed primarily to record pressure, temperature and flow rate values which are the standard variables in hydraulics and pneumatics.

For this purpose, special sensors are available. HMG 2500 recognises the measured value, measuring range and the unit of these sensors and automatically carries out the basic device settings accordingly.

In addition to this, the HMG 2500 has a digital input, i.e. for frequency or speed measurement, as well as a virtual measuring channel for the measurement of difference or performance.

Due to the wide range of functions and its simple handling, the HMG 2500 is just as appropriate for users who take measurements only occasionally as it is for professionals for whom measuring and documentation are routine.

The update capability of the HMG 2500 ensures that the user can benefit from future upgrades of the device software.

Features

- Simple and user-friendly operation
- Practical, robust design
- Large, full-graphics colour display
- Quick and independent basic setting of the units by the use of automatic sensor recognition
- Up to 4 sensors can be connected simultaneously
- Up to 32 measurement channels can be depicted simultaneously
- Measurement rates up to 0.1 ms
- Very large data memory for archiving measurement curves
- Various measurement modes:
 - Measuring
 - Fast curve recording
 - Long term measurements
- 2 independent triggers, can be linked logically
- Simple sensor connection by means of M12x1 push-pull connector
- PC connection
 - USB
 - RS 232
- Convenient visualisation, archiving and data processing using the HMGWIN and CMWIN software supplied

Technical Specifications

Analogue inputs	
Input signals 3 channels M12x1 Ultra-Lock flange sockets (5 pole) channel A .. channel C	HYDAC HSI analogue sensors HYDAC HSI SMART sensors
Accuracy	≤ ± 0.1 % FS
Digital input	
1 channel via M12x1 Ultra-Lock flange socket (5 pole) Channel D	Digital status (high/low) Frequency (0.01 .. 30,000 Hz)
Calculated channel	
Quantity	1 channel via virtual channel E
Sampling rate (dependent on number of active channels)	0.1 ms, max. 1 input channel 0.2 ms, max. 2 input channels 0.5 ms, all 3 input channels 1.0 ms, for Smart sensors
Resolution	12 bit
Memory	At least 100 measurement curves, each with 500,000 measured values
Display	3.5" colour display 7-segment display
Interfaces	1 USB, 1 serial port RS 232
CE mark	EN 61000-6-1 / 2 / 3 / 4
Safety	EN 61010
Protection class	IP 40
Environmental conditions	
Operating temperature	0 .. +50 °C
Storage temperature	-20 .. +60 °C
Relative humidity	0 .. 70 %
Dimensions	approx. 244 x 173 x 58 mm (B x H x T)
Weight	approx. 1,100 g

Note: FS (Full Scale) = relative to complete measuring range

Model Code

HMG 2500 - 000 - X

Operating Manual & Documents

US = English

Scope of delivery

- HMG 2500
- Power supply for 90 .. 230 V AC
- Operating manual
- Data carrier with USB drivers, HMGWIN software
- USB connector cable

Accessories

- Additional accessories, such as electrical and mechanical connection adapters, power adapters, etc. can be found in the "Accessories Service Devices" catalogue section

Dimensions

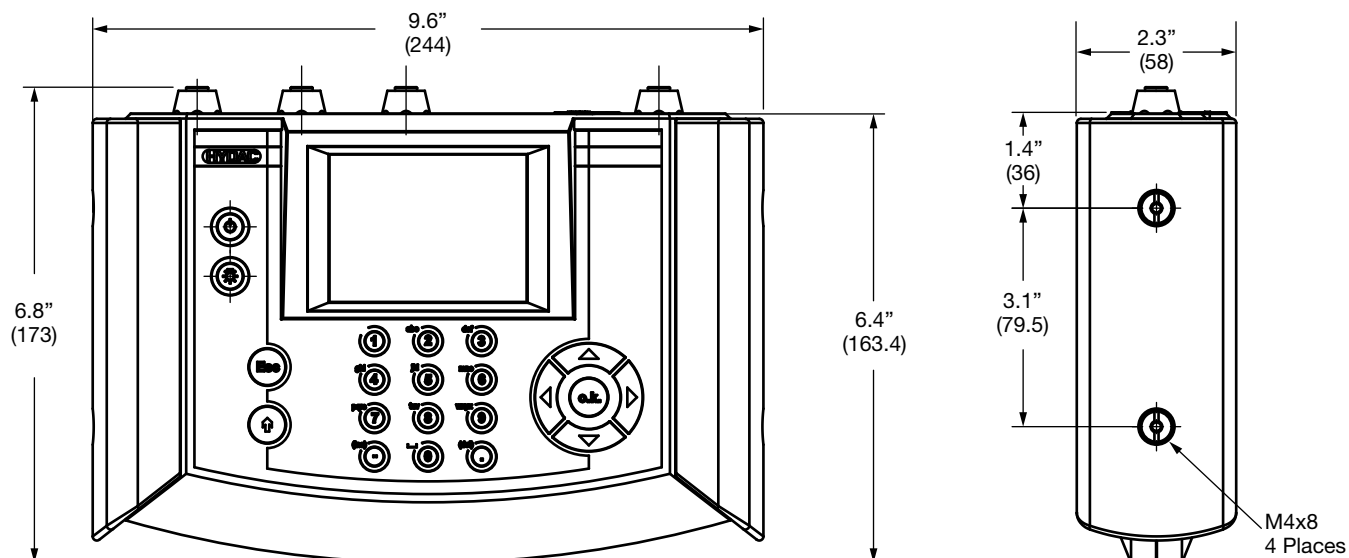

Dimensions are for general information only, all critical dimensions should be verified by requesting a certified print.

DIAGNOSTICS

Function

- Clear and graphical selection menus guide the operator intuitively to all the device functions available. A navigation pad on the keypad ensures rapid operation.
- The HMG 2500 can record signals from up to **four sensors simultaneously**. For this there are 4 robust standard input sockets.
- The following sensors can be connected to 3 of these input sockets:
 - - 3 analogue sensors (e.g. for pressure, temperature and flow rate) with the special digital HSI interface (HYDAC Sensor Interface); this means the basic device settings (measured variable, measuring range and unit of measurement) are undertaken automatically
 - - 3 Condition Monitoring sensors 1) (SMART sensors); again, the basic device settings are carried out automatically
- Frequency measurements, counter functions or triggers for data logging can be implemented via the fourth input socket with one digital input.
- Additionally, the HMG 2500 has a virtual measuring channel. The virtual measuring channel enables a differential measurement or a performance measurement by means of the sensors connected to the measuring channels „A“ and „B“.
- All input channels can operate simultaneously at a **sampling rate** of 0.5 ms (1.0 ms for SMART sensors). For the recording of highly dynamic processes, a sampling rate of 0.1 ms can be achieved.
- The most attractive function of the HMG 2500 surely is the capability of „online“ recording and graphic illustration of dynamic processes, which means as a **measuring curve in real time**.

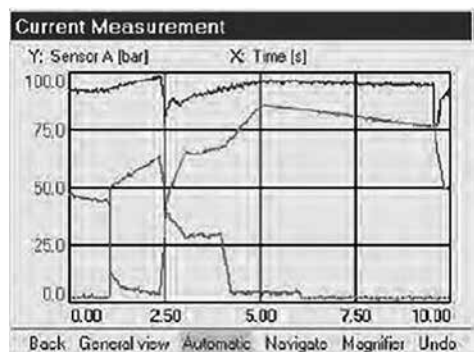

- The data memory for recording curves or logs can hold up to 500,000 measured values per recording. Over 100 of such data recordings in full length can be stored in an additional archiving memory.
- For targeted, event-driven curves or logs, the HMG 2500 has two independent triggers, which can be linked together logically.
- User-specific device settings can be stored and re-loaded at any time as required. This means that repeat measurements can be carried out on a machine again and again using the same device settings.

- Measured values, curves or texts are visualised on a full graphics colour display in different selectable formats and display forms.

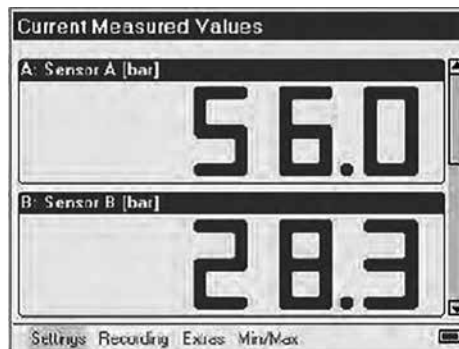

- Numerous useful and easy-to-use auxiliary functions are available, e.g. zoom, ruler tool, differential value graph creation and individual scaling, which are particularly for use when analysing the recorded measurement curves.

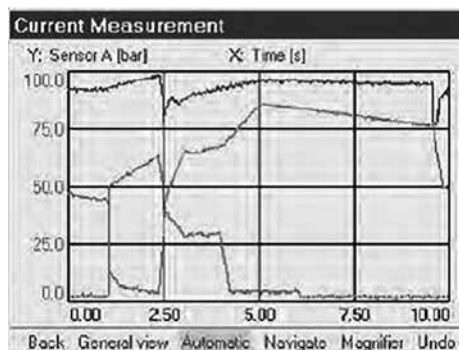

- The HMG 2500 communicates with a PC via the built-in USB interface or RS 232 interface.

HMGWIN:

The PC software HMGWIN is also supplied with the device. This software is a convenient and simple package for analysing and archiving curves and logs which have been recorded using the HMG 2500, or for exporting the data for integration into other PC programs if required.

In addition it is possible to operate the HMG 2500 directly from the computer. Basic settings can be made, and measurements can be started online and displayed directly on the PC screen in real-time as measurement curves progress.

HMGWIN can be run on PCs with Windows Vista / XP / 2000 and Windows 7, 8.1 and 10 operating systems.

Some examples of the numerous useful additional functions:

- **Transfer and archiving** of measurements recorded using the HMG 2500.
- Display of the measurements in graph form or as a table.

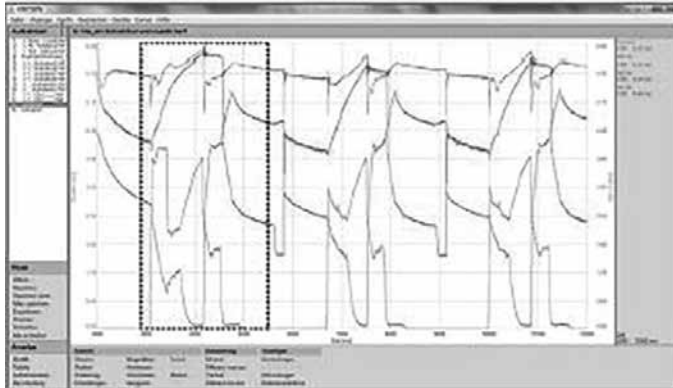

- **Zoom function:** Using the mouse, a frame is drawn around an interesting section of a measurement curve, which is then enlarged and displayed.

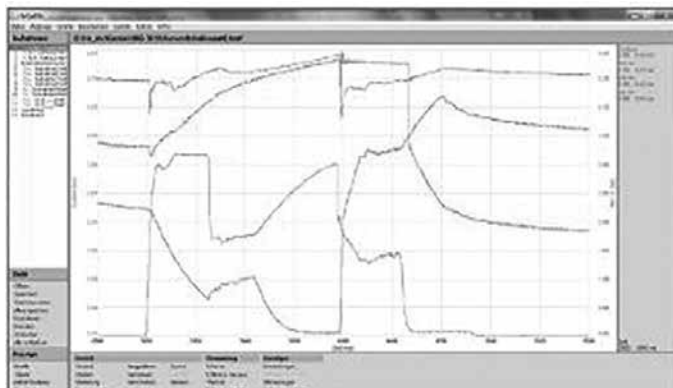

Fig.: Zoomed section of measurement curve

- **Accurate measurement** of the curves using the ruler tool (time values, amplitude values, and differentials)



- Individual **comments** and measurement information can be added to the graph



- **Overlay of curves**, for example to document the wear of a machine (new condition/current condition)

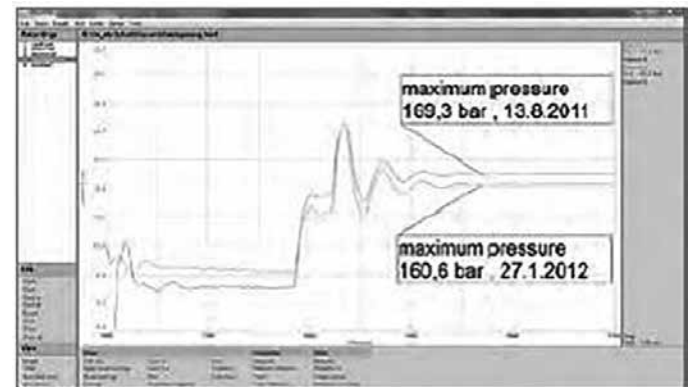

- Using mathematical operations (calculation functions, filter functions) new curves can be added.
- **Snap-shot function:** comparable to the function of a digital camera, a picture can be taken immediately of any graph and saved as a jpg file.
- A **professional measurement report** can be produced at the click of a mouse: HMGWIN 3000 has an automatic layout function. Starting with a table of contents, all recorded data, descriptions, and graphics and/or tables are combined into a professional report and saved as a pdf file.
- Online function (HMGWIN only): Starting, recording, and online display of measurements (similar to the function of an oscilloscope)

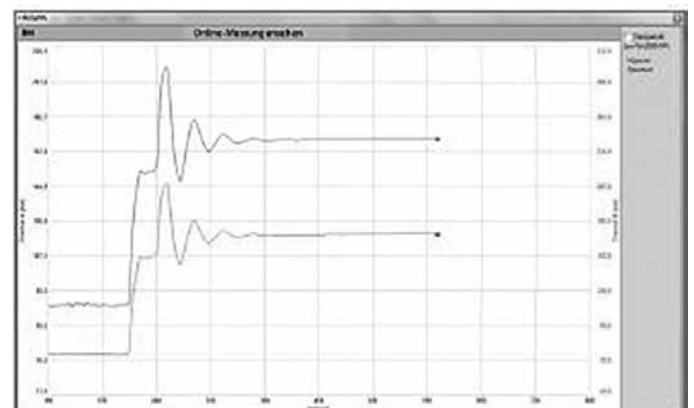

- Change of axis assignment of the recorded measurement parameters in graph mode (e.g. to produce a p-Q graph)

HMG 4000 Series

Portable Data Recorder

5.7" Color Touchscreen
Up to 38 sensors can be connected
Automatic Sensor Detection



Description:

The HMG 4000 is a top performance high-end portable measurement and data acquisition equipment. It was mainly developed for all measured values in relation with hydraulic systems, such as pressure, temperature, flow rate and linear position. Moreover, it provides a very high flexibility, even when it comes to evaluating other measured values. The main applications are servicing, maintenance or test rigs.

The data recorder has a very easy-to-operate user interface due to its large 5.7" touchscreen. The operator can access all of the device's functions and settings by means of clearly presented selection menus.

The HMG 4000 can record the signals of up to 38 sensors at once.

For this purpose, HYDAC ELECTRONIC offer special sensors which are automatically recognised by the HMG 4000 and whose parameters such as measured values, measuring ranges and measuring units can be set.

On the one hand, there are the HYDAC **HSI** sensors (HYDAC Sensor Interface) for the measurement of pressure, temperature and flow rate, for the connection of which there are 8 analogue input channels.

Furthermore, there is the option of connecting HYDAC SMART sensors to these inputs. SMART sensors can display several different measured values at a time.

Up to 28 special HYDAC **HCSI** sensors (HYDAC CAN Sensor Interface) can be connected additionally via the CAN bus port, also supporting automatic sensor recognition.

The HMG 4000 can optionally be connected to an existing CAN network. This enables the recording of measured data transmitted via CAN bus (e.g. motor speed, motor pressure) in combination with the measured data from the hydraulic system.

The device also offers measurement inputs for standard sensors with current and voltage signals.

The HMG 4000 rounds off the application with two additional digital inputs (e.g. for frequency or rpm measurements).

The most impressive feature of the HMG 4000 is its ability to record the dynamic processes of a machine in the form of a measurement curve and render them as a graph.

HYDAC software HMGWIN, which is specific to the HMG 4000, is supplied for convenient post-processing, rendering and evaluation of measurements on your computer.

Features:

- Large, full graphics colour display 5.7" touchscreen
- Capable of recording up to 38 sensors at once, 8 analogue, 2 digital sensors and 28 HCSI sensors via CAN bus.
- Up to 100 measurement channels can be depicted simultaneously
- High-speed sampling rate, up to 8 sensors at 0.1 ms at a time.
- Quick and automatic basic setting by use of automatic sensor recognition
- Analogue inputs 0 .. 20 mA, 4 .. 20 mA Voltage 0 .. 50 V, -10 .. 10 V
- PT 100/1000 input
- Connection to a CAN bus system (also J1939)
- Simple and user-friendly operation, intuitive menu
- Practical, robust design
- Very large data memory for archiving measurement curves, enables the storage of 500 measurements with up to 8 million measured values.
- Various measurement modes:
 - Normal measuring
 - Fast curve recording
 - Long-term measurements
- Recording of dynamic processes „online“ in real time
- Event-driven measurements with several triggering options
- Programming function for HYDAC switch devices
- PC interface via USB
- USB Host connection for USB memory sticks
- Convenient visualisation, archiving and data processing using the HMGWIN software supplied.

Model Code

HMG 4000 - 000 - X

Operating Manual & Documents

US = English

Technical Specifications:

Analogue inputs	
Input signals 8 channels M12x1 Ultra-Lock flange sockets (5-pin) channel A to channel H	HYDAC HSI analogue sensors HYDAC HSI SMART sensors Voltage signals: e.g. 0.5 to 4.5 V, 0 to 10 V etc. (input ranges for 0 to 50 V, 0 to 10 V, 0 to 4.5 V, -10 to 10 V) Current signals, e.g. 4 to 20 mA, 0 to 20 mA (input range 0 to 20 mA) 1 x PT 100 / PT 1000 (at channel H)
Accuracy dependent on the input range	$\leq \pm 0.1$ % FS at HSI, voltage, current $\leq \pm 1$ % FS at PT 100 / PT 1000
Digital inputs	
Input signals 2 channels M12x1 Ultra-Lock flange socket (5-pin) channel I, J Level	Digital status (high/low) Frequency (0.01 to 30,000 Hz) PWM duty cycle Durations (e.g. period duration)
Accuracy	Switching threshold/switch-back threshold: 2 V/1 V Max. input voltage: 50 V $\leq \pm 0.1\%$
CAN	
Input signals 28 channels M12x1 Ultra-Lock flange socket (5-pin) channel K1 to K28	HYDAC HCSI sensors, CAN, J1939, CANopen PDO, CANopen SDO
Baud rate	10 kbit/s to 1 Mbit/s
Accuracy	$\leq \pm 0.1\%$
Calculated channels	
Quantity	4 channels via virtual port L (channel L1 to channel L4)
Programming interface	
For HYDAC I/O-Link devices	1 channel via M12x1 Ultra-Lock flange socket (5-pin)
Voltage supply	
Network operation	9 to 36 V DC via standard round plug 2.1 mm
Battery	Lithium-Nickel-Kobalt-Aluminium-Oxide 3.6 V; 9300 mAh
Battery charging time	approx. 5 hours
Battery life	w/o sensors roughly 11 hours with 2 sensors roughly 9 hours with 4 sensors roughly 7 hours with 8 sensors roughly 4 hours
Display	
Type	TFT-LCD Touchscreen
Quantity	5.7"
Resolution	VGA 640 x 480 Pixel
Backlight	10 to 100% adjustable
Interfaces	
USB Host	
Plug-in connection	USB socket, Type A, screened
USB Standard	2.0 (USB Full speed)
Transmission rate	12 Mbit/s
Voltage supply	5 V DC
Power supply	100 mA max.
Protection	Short-circuit protection to GND (0 V)
USB Slave	
Plug-in connection	USB socket, Type B, screened
USB Standard	2.0 (USB High speed)
Transmission rate	480 Mbit/s
Voltage supply	5 V DC
Power supply	100 mA max.
Protection	Short-circuit protection to GND (0 V)
Memory	
Measured value memory	16 GB for min. 500 measurements, each containing 8 million measured values
Technical standards	
EMC	IEC 61000-4-2 / -3 / -4 / -5 / -6 / -8
Safety	EN 61010
IP class	IP 40
Environmental conditions	
Operating temperature	32 to 122°F (0 to 50°C)
Storage temperature	-4 to 140°F (-20 to 60°C)
Relative humidity	0 to 70%
Max. operating altitude	2000 m
DIMENSIONS	approx. 11.2" x 7.4" x 3.4" (285 x 189 x 87 mm)
Weight	approx. 4.1 lb. (1.85 kg)
Housing material	Plastic (Elastollan® R 3000 – TPU-GF)

Scope of delivery

- HMG 4000
- Power supply for 90 to 230 V AC
- Tether strap
- Operating Instructions
- Data carrier with USB drivers and HMGWIN software
- USB connector cable

Accessories

- Pressure, temperature and flow rate measuring transmitter with HSI sensor detection and CAN pressure measuring transmitter with HCSI sensor detections – see separate data sheet
- Additional accessories, such as the push-pull sensor connection cables, connection accessories for the HCSI CAN sensors, mechanical connection adapters, etc. can be found in the "Accessories Service Devices" catalog section.

Note:

The information in this brochure relates to the operating conditions and applications described.

For applications or operating conditions not described, please contact the relevant technical department.

All technical details are subject to change without notice.

DIAGNOSTICS

Function:

- Clear and graphical color selection menus intuitively guide the operator to all the device functions available and ensure fast implementation.

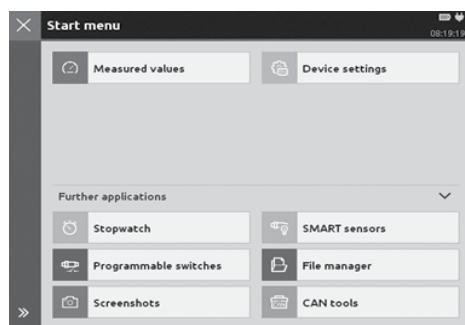

- The HMG 4000 can record the signals of up to **38 sensors simultaneously**.
11 push-pull M12x1 input sockets are available as sensor interfaces. Apart from the push-pull sensor connection cable, M12x1 standard cables can also be used.
- The following sensors can be connected to the 8 black input sockets:
 - 8 analogue sensors (e.g. for pressure, temperature, and flow rate) with the special digital HSI interface (HYDAC Sensor Interface); this means the basic device settings (measured variable, measuring range and unit of measurement) are undertaken automatically
 - 8 standard analogue sensors with current and voltage signals
 - 8 Condition Monitoring sensors* (SMART sensors); again, the basic device settings are carried out automatically
- The blue input socket provides 2 digital inputs, e.g. for 1 or 2 HYDAC speed sensors (2nd speed sensor connection via Y adapter). Frequency measurements, counting functions or triggers can also be implemented for data recording.
- Different **CAN bus** functions can be implemented via the red input socket:
 - Connection of up to 28 HYDAC **HCSI** sensors (HYDAC CAN Sensor Interface) by setting up a CAN bus with HCSI sensors and the relevant connection accessories, also with automatic parameterization.
 - Connecting to a CAN bus, you have the option of evaluating up to 28 CAN messages.
 - Configuration of **CAN sensors**; the parameterization is performed by means of EDS files, which can be stored and administrated in the HMG 4000.
- The yellow input socket serves as the interface for HYDAC pressure, temperature or level switches with **I/O link** as well as for the programming device HPG P1. These devices can be parameterized by means of the HMG 4000.
- The most attractive function of the HMG 4000 surely is the capability of “online” recording and graphic illustration of dynamic processes, which means as a measuring curve in real time. During the recording process of a measuring curve, you can zoom in the curve sections of interest using gestures on the touchscreen.

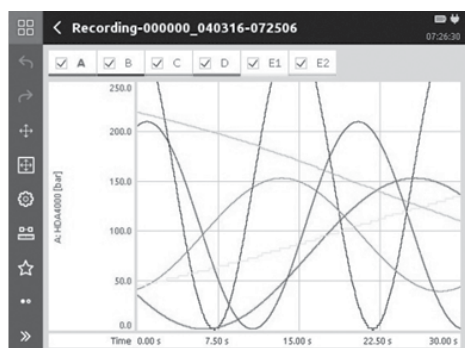

- For the purpose of recording highly dynamic processes, all 8 analogue input channels can be operated simultaneously at a **sampling rate** of 0.1 ms.
- The **data memory** for recording curves or logs can hold up to 8 million measured values.
At least 500 of such data recordings in full length can be stored in an additional archiving memory.
- For specific, **event-driven curves or logs**, the HMG 4000 has four independent triggers, which can be linked together logically. In addition, there is a "start/stop" condition, by means of which a measurement can be initiated or finished.
- User-specific device settings can be stored and re-loaded at any time as required. This means that repeat measurements can be carried out on a machine again and again using the same device settings.

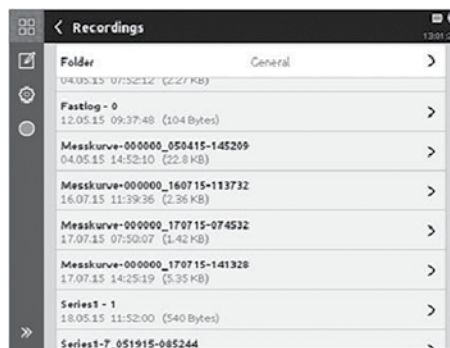

- Measured values, curves or texts are visualized on the **full color graphics** display in different selectable formats and display forms.

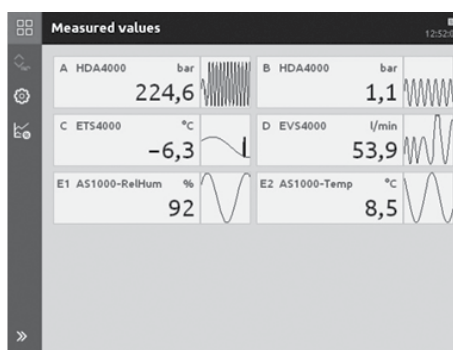

- Numerous useful and easy-to-use **auxiliary functions** are available, e.g. zoom, tracker, differential value graph creation and individual scaling, which are particularly for use when analyzing the recorded measurement curves.

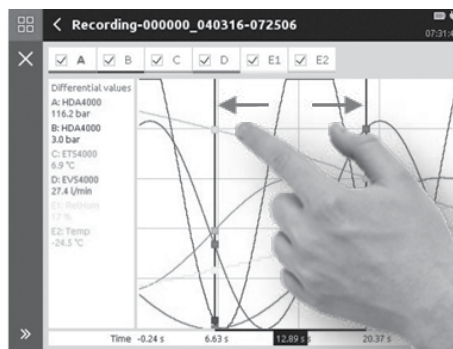

Figure: Using the magnifying gesture with two fingers, the operation is carried out – zooming in this case

- The communication between the HMG 4000 and a PC is performed via the built-in USB port. A HMG 4000 connected to your PC is recognized and depicted as a drive by the PC. You can thus move measured data to your PC conveniently. Optionally, data transfers can be carried out via a file manager by means of a USB memory stick.

HMGWIN:

The PC software HMGWIN is also supplied with the device. This software is a convenient and simple package for analyzing and archiving curves and logs which have been recorded using the HMG 4000, or for exporting the data for integration into other PC programs if required.

In addition it is possible to operate the HMG 4000 directly from the computer. Basic settings can be made, and measurements can be started online and displayed directly on the PC screen in real-time as measurement curves progress.

HMGWIN can be run on PCs with Windows 7, Windows 8.1 and Windows 10 operating systems.

Some examples of the numerous useful additional functions:

- Display of the measurements in graph form or as a table

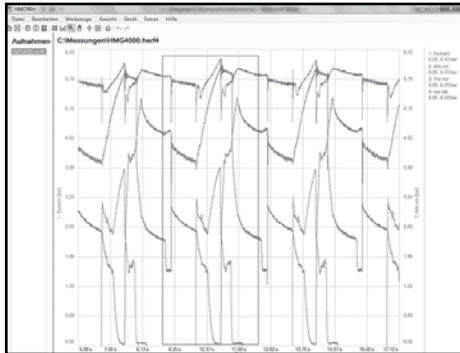

- **Zoom function:**

Using the mouse, a frame is drawn around an interesting section of a measurement curve, which is then enlarged and displayed.

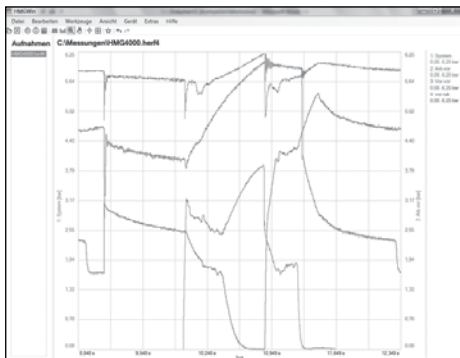
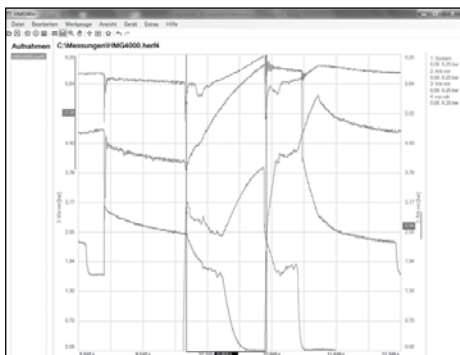
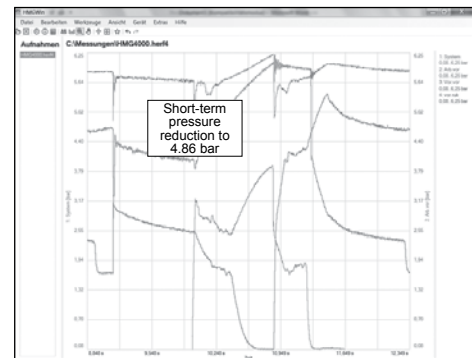

Fig.: Zoomed section of measurement curve

- Accurate measurement of the curves using the ruler tool (time values, amplitude values and differentials)



- Individual comments and measurement information can be added to the graph (function available mid-2017)



- Overlay of curves, for example to document the wear of a machine (new condition/current condition) (function available mid-2017)

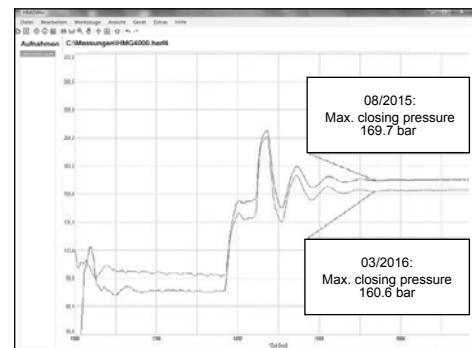

- Using mathematical operations (calculation functions, filter functions), new curves can be added.
- Snap-shot function: comparable to the function of a digital camera, a picture can be taken immediately of any graph and saved as a jpg file.
- A professional measurement report can be produced at the click of a mouse: HMGWIN has an automatic layout function. Starting with a table of contents, all recorded data, descriptions and graphics and/or tables are combined into a professional report and saved as a pdf file.
- Online function (HMGWIN only): Starting, recording, and online display of measurements (similar to the function of an oscilloscope) Change of axis assignment of the recorded measurement parameters in graph mode (e.g. to produce a p-Q graph)

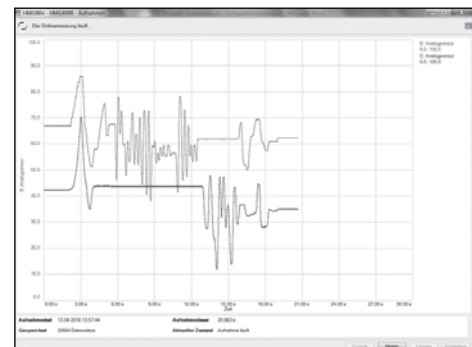

* SMART sensors

(Condition Monitoring sensors) are a generation of sensors from HYDAC which can provide a variety of different measurement variables.

DIAGNOSTICS

Notes

A large grid of graph paper for taking notes, consisting of 20 columns and 30 rows of small squares. A solid red vertical bar is located on the left edge of the page, partially overlapping the grid.

D Offline Filtration Systems

Today's hydraulic filter systems have seen a shift from reactionary to preventative, and even predictive maintenance. Total system contamination management begins with our Fluid Conditioning Products. These are hydraulic oil filter systems for removing contaminants and water from various types of hydraulic fluids. Our offline hydraulic oil filter systems include both mobile filtration carts with and without contamination monitoring units, stationary filtration systems from 1.3 gpm flow rates to customizable kidney loop systems up to 140 GPM. Our dewatering units, both vacuum dehydration and mass transfer systems offered and can remove both free and dissolved water from fluids for any reservoir size at various flow rates.

OFFLINE FILTRATION SYSTEMS

RFSA Series

Reservoir Filtration System Adapter



Description

The RFSA is an aluminum adapter that gives a kidney loop filter access to a reservoir. The adapter can accommodate kidney loop filtration rates up to approximately 15 gpm.

Features

- Suitable to use with many Filter Systems products including: OF5HS/OF5HD/OFCS/OFCD, OF7-BC, OFCD-BC, OFCD-MV, OFCD-HV, MAFH-A, OFS, OFS-AM, OLF
- 1.25" SAE O-Ring Boss Suction Port
- 1.00" SAE O-Ring Boss Return Port
- Suction and Return downtubes included and recommended to be cut to length and bent for proper fluid turnover in a reservoir
- Optional OFCS/OFCD Fitting Kit can be ordered separately. This includes adapters to install CAM-GROOVE hose couplings between Suction/Return hoses/wands and additional CAM-GROOVE adapters for installation in kidney loop adapter. Dust caps and plugs included

Applications

- All applications with a hydraulic reservoir utilizing a 6-bolt mounting connection

Technical Specifications

Reservoir Mounting Pattern:	Fits standard 6-bolt
Supply Port Thread Size:	1.25" SAE O-Ring Boss Suction Port
Return Port Thread Size:	1.00" SAE O-Ring Boss Return Port
Breather Port Thread Size:	3/4" NPT
Return Tubes:	Suction and Return downtubes included and recommended to be cut to length and bent for proper fluid turnover in reservoir

Mounting Pattern

Customer is responsible to cut an appropriately sized hole on top of their tank. This adapter has two (2) ports: one for Suction and one for Return. Also includes a breather port.

Reservoir pattern is six (6) .203" holes on a 4.94" BCD with a 4.25" diameter center hole. See Drawing S-1048.

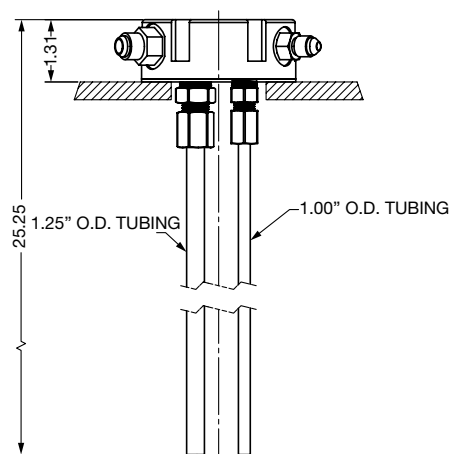
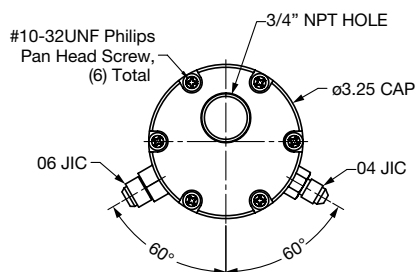
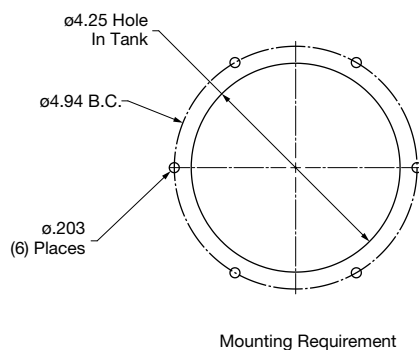

Model Code

RFSA - 1

Series

RFSA = Reservoir Filtration System Adapter

Options

Omit = For use with Kidney Loop Filtration Products
 1 = Optional OFCS/OFCD Fitting Kit

Installation Details

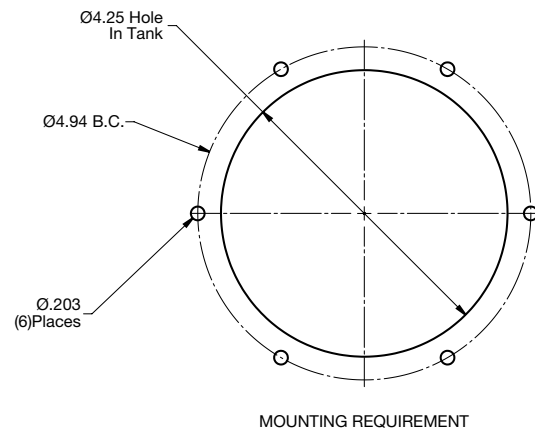
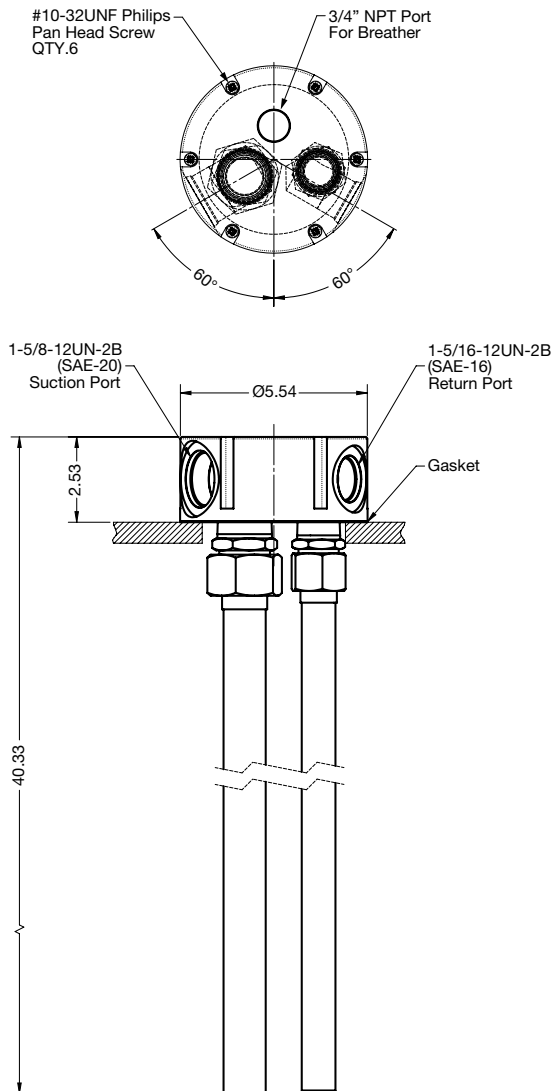

OFFLINE FILTRATION SYSTEMS

OF7-BC Series

Compact Filtration System Basic Cart



Description

The HYDAC Basic Cart Filter System is a compact, self-contained, “light-duty” filtration system equipped with high efficiency, high capacity elements capable of removing particulate contamination and/or water quickly, conveniently and economically. It is perfect for cleaning up existing systems as well as for pre-filtering new fluids, since new fluids often have contamination levels significantly higher than that recommended for most hydraulic systems.

The filtration system’s compact, lightweight design with replaceable element cartridge and reusable bowl, minimizes landfill waste. Element service is easily accomplished through the top-ported filter housings. The optional dual filter assembly allows for water and particulate removal or staged particulate contamination removal.

Features

- Compact size, easily transported
- Top-ported filter provides easy element service
- Bar-type Dirt Alarm® indicates when filter elements require a change
- Hoses and connection tubes included
- Optional BackPack Version available for ease of transport across distances

Applications

- Supplementing continuous filtration by system filters
- Cleaning up a hydraulic system following component replacement
- Filtering new fluid before it is put into service
- Transferring fluid from storage tanks and drums to system reservoirs

Technical Specifications

Flow Rating:	4 gpm (15.1 lpm)
Maximum Viscosity:	1600 SUS (350 cSt)
Hose Pressure Rating:	30 psig (2.0 bar) @ 150°F (65.6°C) Full vacuum @ 150°F (65.6°C)
Fluid Temperature:	25°F to 150°F (-4°C to 65°C)
Material:	Element Case: Aluminum
Seal Material:	Buna N
Compatibility:	All petroleum based hydraulic fluid. Contact factory for use with other fluids
Motor:	115 VAC Single phase 1 hp
Weight:	Single housing - 40 lbs (18.2 kg) Dual housing - 44 lbs (20 kg) BackPack version - 39 lbs (17.7 kg) <i>(Does not include weight of hose/wands)</i>

Replacement Elements

Model Code	Part No.
ELEMENT OFCDBC 003	02099361
ELEMENT OFCDBC 005	02099362
ELEMENT OFCDBC 010	02099363
ELEMENT OFCDBC 020	02099364
ELEMENT OFCDBC AM	02099365

Model Code

OF7-BC - K - 1 - 09 - MXxx - MXxx - B - E

Series

OF7-BC = Compact Filter System Basic Cart

Voltage

- omit = 110 V AC, 60Hz, 1 Ph.
- A = 230V AC, 60Hz, 1 Ph.
- T = 12V DC (supplied with motor starter)

Number of Housing

- 1 = One 9" element per housing
- 2 = One 9" element per housing

Element Length

- 09 = One 9" element supplied per housing

Element Size (BN only - AM has no rating) (microns)

- MX03, MX05, MX10, MX25 = Betamicon® Absolute Filtration Rating ($\beta_{x(c)} \geq 1000$)
- MXAM* = Aquamicon® Water Removal

Element Size (BN only - AM has no rating) (microns) (OF7-BC Dual Stage Only)

- MX03, MX05, MX10, MX25 = Betamicon® Absolute Filtration Rating ($\beta_{x(c)} \geq 1000$)
- MXAM* = Aquamicon® Water Removal

Seals

- B = Buna

Clogging Indicator

- E = Standard Visual Indicator

Options

- BP = Backpack Version (Single Housing Only)

*Aquamicon media should be in the first filter housing followed by the BN media in the second housing.

Dimensions

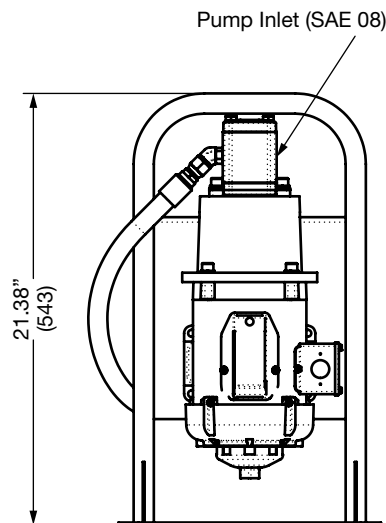
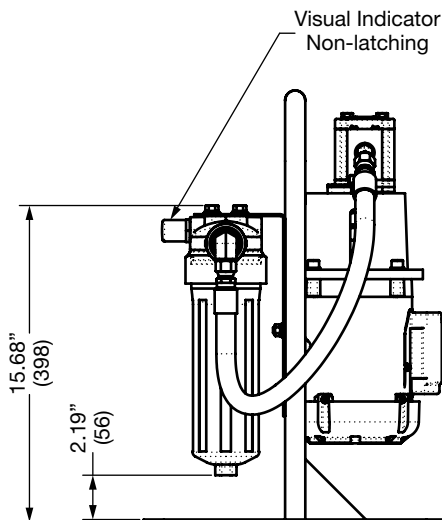
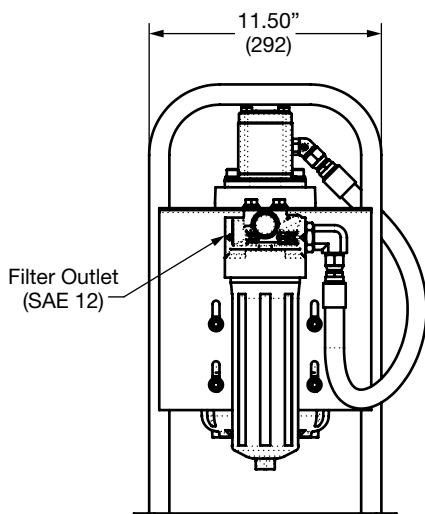
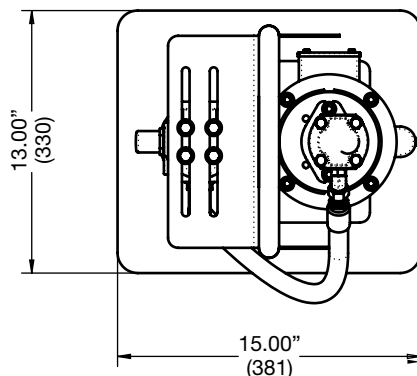

Dimensions are for general information only, all critical dimensions should be verified by requesting a certified print.

OFFLINE FILTRATION SYSTEMS

HFS-15 Series

Mobile Filter Unit



Hydraulic Schematic

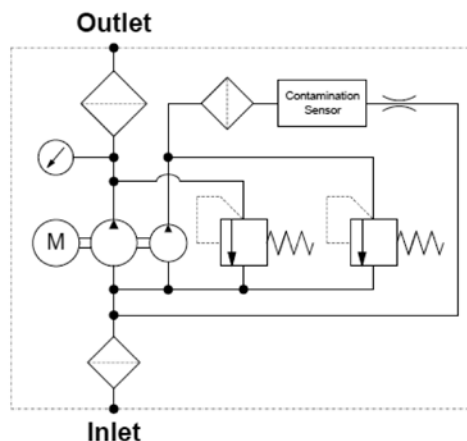
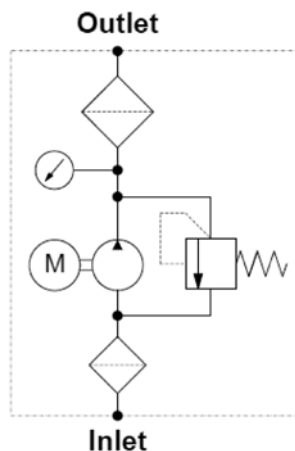

Description

The HFS MobileFiltration unit is used as a portable service unit for filling hydraulic systems, flushing small hydraulic systems as well as for cleaning in bypass flow. Solid particle contamination as well as free water can be removed by the filter elements.

The HFS can also be fitted with a CS 1000 ContaminationSensor. This allows the solid particle contamination in the oil to be monitored at the same time. The cleanliness class results are displayed according to ISO, SAE or NAS classifications.

Features

- Improvement in service life for components and system filters
- Increased oil service life
- Increased machine availability
- Simple operation
- Compact design
- Integrated dry running protection
- Option: CS 1000 ensures continuous monitoring of oil cleanliness during cleaning

Applications

- Filtered and unfiltered filling of hydraulic systems
- Temporary offline filtration of hydraulic systems
- Filtered or unfiltered fluid transfer
- Unfiltered drainage of hydraulic tanks
- Leakage oil recirculation at test benches

Technical Specifications

Maximum Flow Rating	HFS-E: 4 gpm (15 l/min) HFS-P: 2.6 gpm (10 l/min)
Pump type	Vane pump
Maximum operating pressure	58 psi (4.0 bar)
Permitted suction pressure at suction port	-5.8 to 8.7 psi (-0.4 bar to + 0.6 bar)
Viscosity range	HFS-E: 42 SUS 1623 SUS (5 to 1000cSt) HFS-P: 42 SUS 927 SUS (5 to 200cSt)
Length of power cable	9.8' (3 m) (incl. plug)
Permissible fluid temp.	14-176°F (-10 ... +80 °C)
Permitted ambient temperature range	14-104°F (-10 to +40°C)
Seal material	FKM (FPM, Viton®)
Empty weight	HFS-E: 30.9 lb (14 kg) HFS-P: 36.4 lb (16.5 kg)

Model Code

HFS - 15 - E - 9 - DM - 2 - S - K - F - E

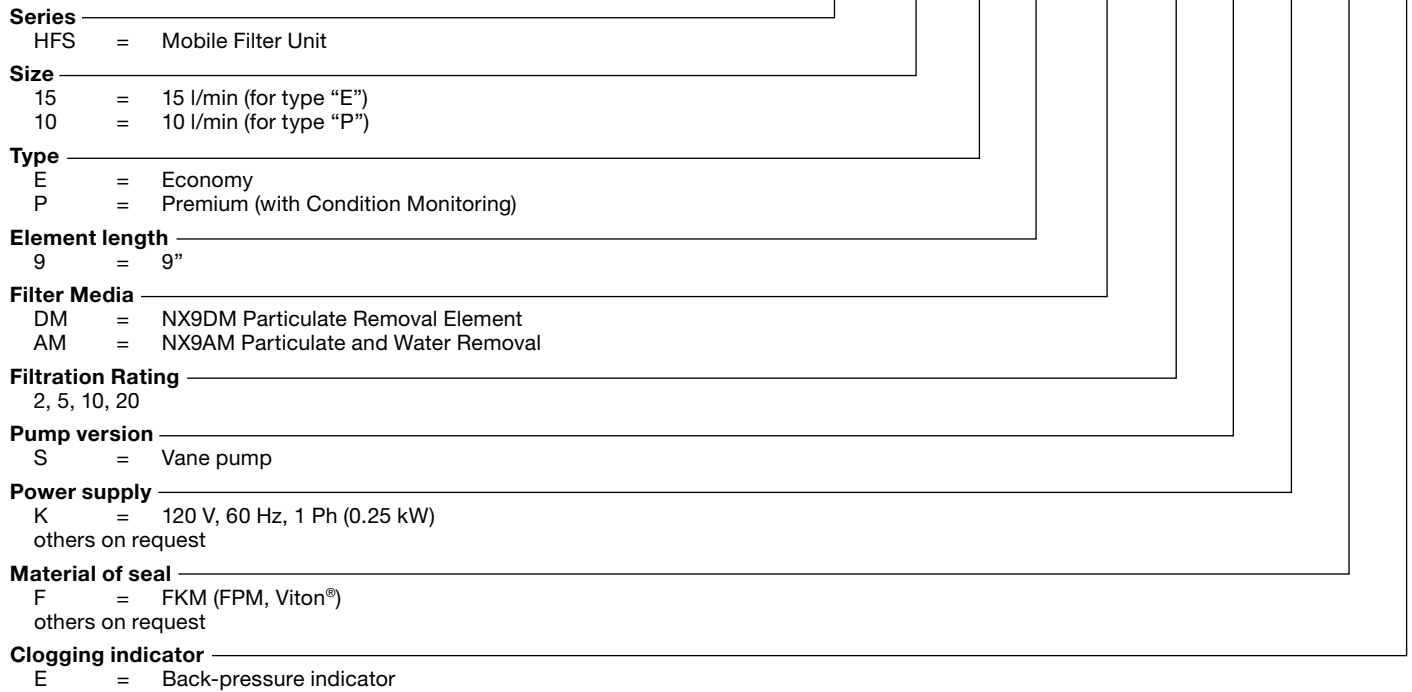

Scope of delivery

- HFS (with filter element and hoses)
- Operating and maintenance instructions

Description	Part no.	Filtration rating	Water absorption
Filtration			
NX9DM002-F	4265955	2 µm	-
NX9DM005-F	4265956	5 µm	-
NX9DM010-F	4265957	10 µm	-
NX9DM020-F	4265958	20 µm	-
Filtration and dewatering			
NX9AM002-F	4265959	2 µm	Ⓡ
NX9AM005-F	4265960	5 µm	Ⓡ
NX9AM010-F	4265961	10 µm	Ⓡ
NX9AM020-F	4265962	20 µm	Ⓡ
Adapter for unfiltered operation			
NX9-xxxx-F	4265963	-	-

OFFLINE FILTRATION SYSTEMS

Optional Hose Assemblies Offered

Hoses with lance (depressurized suction up to max. 350 mm²/s)

Description	Part no.	Suction hose / Pressure hose	Lance	Material Suction / pressure hose
HFS-15-SDN	4270478	8.2' (2.5 m) / 08.2' (2.5 m)	.82' (0.25 m)	PVC / PVC*
HFS-15-SDF	4270479	8.2' (2.5 m) / 08.2' (2.5 m)	.82' (0.25 m)	1SN / 2TE
HFS-15-SD5N	4270480	8.2' (2.5 m) / 16.4' (5 m)	.82' (0.25 m)	PVC / PVC
HFS-15-SD5F	4270481	8.2' (2.5 m) / 16.4' (5 m)	.82' (0.25 m)	1SN / 2TE

*Included with HFS-15

Hoses with threaded connection (depressurized suction up to max. 350 mm²/s)

Description	Part no.	Suction hose / Pressure hose	Thread	Material Suction / pressure hose
HFS-15-SKDKN	4270482	08.2' (2.5 m) / 08.2' (2.5 m)	M30x2 / M26x1.5	PVC / PVC
HFS-15-SKDKF	4270483	08.2' (2.5 m) / 08.2' (2.5 m)	M30x2 / M26x1.5	1SN / 2TE
HFS-15-SKDK5N	4270484	08.2' (2.5 m) / 16.4' (5 m)	M30x2 / M26x1.5	PVC / PVC
HFS-15-SKDK5F	4270516	08.2' (2.5 m) / 16.4' (5 m)	M30x2 / M26x1.5	1SN / 2TE

Accessories for hoses with threaded connection

Description	Part no.	Function
HFS-15-SKDK-LF	4270559	Lance1 (length of 4.3') (1.30 m)
HFS-15-SKDK-SF	4270560	Suction filter ¹
HFS-15-SKDK-ZWF	4270518	Counter
HFS-15-SKDK-ZPF	4270561	Pump nozzle ²
HFS-15-SKDK-ZPWF	4270519	Pump nozzle + counter ²

¹ max. viscosity 927 SUS (200 cSt)

² max. operation duration of the unit with closed pump nozzle of 5-10 min.

Dimensions – HFS-15E

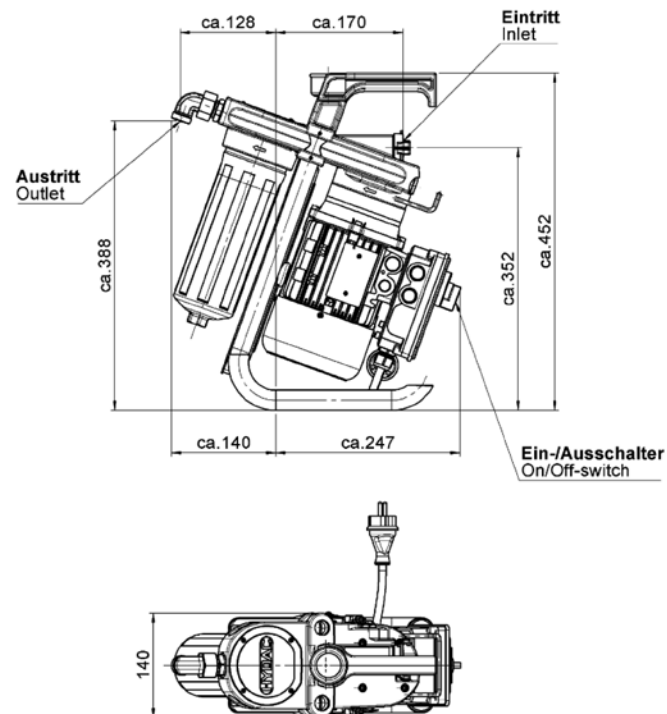

Dimensions – HFS-15P

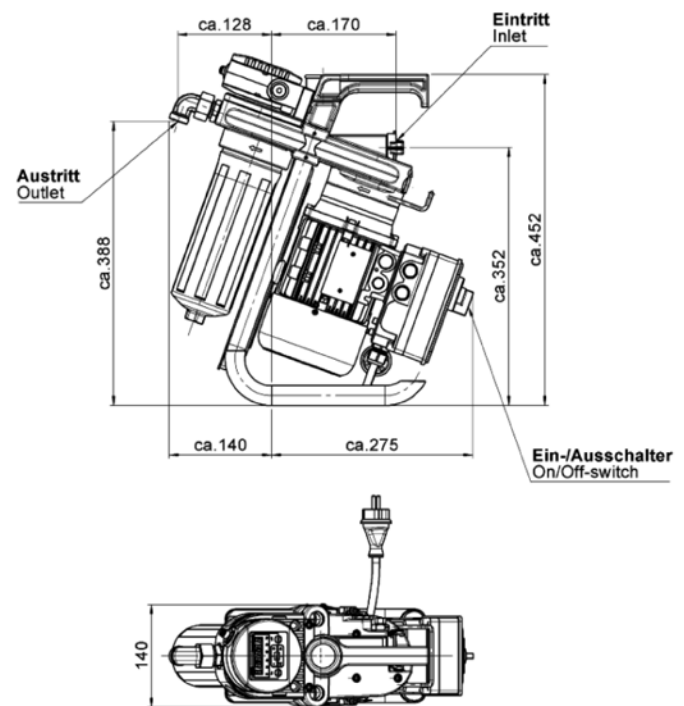

Dimensions are millimeters and for general information only, all critical dimensions should be verified by requesting a certified print.

OFFLINE FILTRATION SYSTEMS

OFCD-BC Series

Compact Dual Stage Filtration System Basic Cart



Description

The HYDAC Basic Cart Mobile Filter System is a compact, self-contained, “light-duty” filtration system equipped with high efficiency, high capacity elements capable of removing particulate contamination and/or water quickly, conveniently and economically. It is perfect for cleaning up existing systems as well as for pre-filtering new fluids, since new fluids often have contamination levels significantly higher than that recommended for most hydraulic systems.

The filtration system’s compact, lightweight design with replaceable element cartridge and reusable bowl, minimizes landfill waste. Element service is easily accomplished through the top-ported filter housings. The OFCD-BC includes a drip pan to help catch any oil before it falls to the ground. The dual filter assembly allows for water and particulate removal or staged particulate contamination removal.

Features

- Compact size, easily transported
- Top-ported filter provides easy element service
- Bar-type Dirt Alarm® indicates when filter elements require a change
- Hoses and connection tubes included
- Drip pan catches oil before it falls to the ground

Applications

- Supplementing continuous filtration by system filters
- Cleaning up a hydraulic system following component replacement
- Filtering new fluid before it is put into service
- Transferring fluid from storage tanks and drums to system reservoirs

Technical Specifications

Flow Rating:	10 gpm (37.9- L/min) max
Maximum Viscosity:	1000 SUS (216 cSt)
Hose Pressure Rating:	30 psig (2.0 bar) @ 150°F (65.6°C) Full vacuum @ 150°F (65.6°C)
Fluid Temperature:	25°F to 150°F (-4°C to 65°C)
Bypass Valve Setting:	Cracking: 25 psi (1.7 bar)
Material:	Element Case: Aluminum
Seal Material:	Buna N
Compatibility:	All petroleum based hydraulic fluid. Contact factory for use with other fluids
Motor:	115 VAC Single phase 1 hp
Weight:	102 lbs. (46.3 kg)

Replacement Elements

Model Code	Part No.
ELEMENT OFCDBC 003	02099361
ELEMENT OFCDBC 005	02099362
ELEMENT OFCDBC 010	02099363
ELEMENT OFCDBC 020	02099364
ELEMENT OFCDBC AM	02099365

Model Code

OFCD-BC - 1 - 09 MX10 - MX05 - B - 10

Series

OFCD-BC = Compact Dual Stage Filter System Basic Cart

Number of Elements

1 = One 9" element per housing

Element Length

09 = One 9" element supplied per housing

Element Size (BN only - AM has no rating) (microns)

MX03, MX05, MX10, MX20 = Betamicon® Absolute Filtration Rating ($\beta_x(c) \geq 1000$)

MXAM* = Aquamicon® Water Removal

Element Size (BN only - AM has no rating) (microns)

MX03, MX05, MX10, MX25 = Betamicon® Absolute Filtration Rating ($\beta_x(c) \geq 1000$)

MXAM* = Aquamicon® Water Removal

Seals

B = Buna

Pump

10 = 10 gpm

Voltage

(Omit) = 115 VAC 60 Hz

A = 230 VAC 60 Hz

B = 230 VAC 50 Hz (flow rate reduced to 8gpm; no plug supplied)

*Aquamicon media should be in the first filter housing followed by the BN media in the second housing.

Dimensions

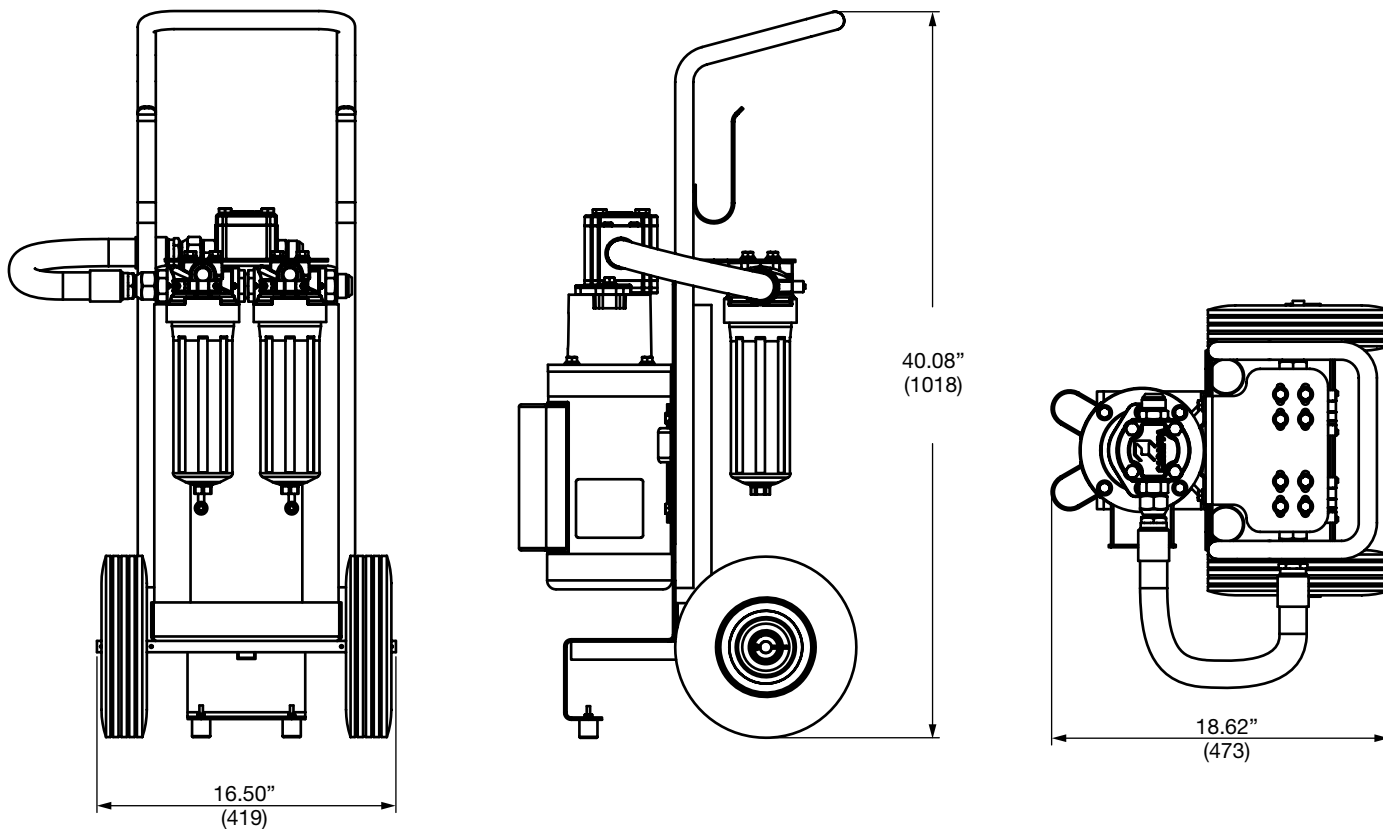

Dimensions are for general information only, all critical dimensions should be verified by requesting a certified print.

OFFLINE FILTRATION SYSTEMS

OFCS & OFCD Series

Single & Dual Stage Filtration Systems

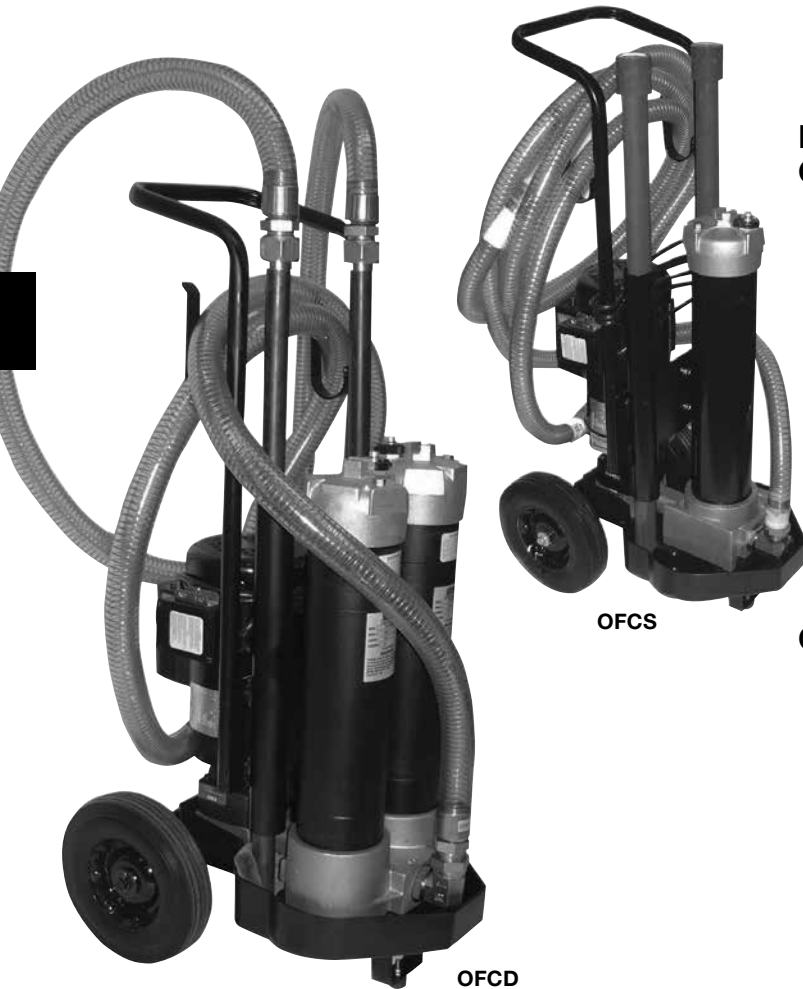

Hydraulic Schematics OFCS Series

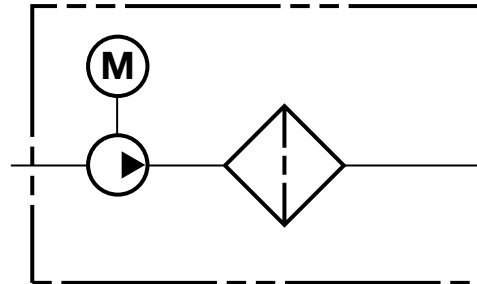

OFCD Series

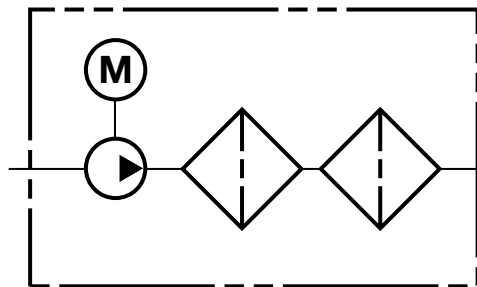

Description

The OFCS and OFCD Series are compact, self-contained filtration system equipped with high efficiency, high capacity elements capable of removing particulate contamination and/or water quickly, conveniently and economically. It is perfect for cleaning up existing systems as well as for prefiltering new fluids, since new fluids often have contamination levels significantly higher than that recommended for most hydraulic systems.

HY-TRAX manual fluid sampling system: HYDAC now offers the HY-TRAX manual fluid sampling system as an additional option allowing for real-time fluid condition monitoring. ISO particle counts are visually displayed on the CS1000. Users will now know when they have reached their desired ISO contamination levels.

CSI-C-11: HYDAC also offers the CSI-C-11 Communication Interface for WLAN or LAN transmission of data and data storage capabilities.

The OFCS single filtration unit can remove either water or particulate contamination. The OFCD dual filtration unit can be used to remove both water and particulate contamination, or for staged particulate contaminant removal.

Features

- Modular base eliminates hoses between components and minimizes leakage
- Base-ported filter provides easy element service from the top cap
- Ten-foot hose and extension tubes included (1" dia. for 7 gpm; 1.25" dia. for 14 gpm)
- Drip pan catches oil before it falls to the ground
- Integral suction strainer protects pump

Applications

- Supplementing continuous filtration by system filters
- Cleaning up a hydraulic system following component replacement
- Filtering new fluid before it is put into service
- Transferring fluid from storage tanks and drums to system reservoirs

Technical Specifications

Flow Rating	7 gpm max (26.5 lpm) or 14 gpm max (53 lpm)	
Maximum Viscosity	1000 SUS (216 cSt) Higher viscosity version available.	
Hose Pressure Rating	30 psig (2.0 bar) @ 150°F (65.6°C) Full vacuum @ 150°F (65.6°C)	
Maximum Operating Temperature	-20° to 150°F (-29° to 65°C)	
Bypass Valve Setting	Cracking: 30 psi (2 bar)	
Material	Manifold and cap: Cast aluminum Element case: Steel	
Compatibility	All petroleum based hydraulic fluid. Contact factory for use with other fluids.	
Motor	115 V AC Single phase 3/4 hp (7 gpm) or 1-1/2 hp (14 gpm)	
Weight - lbs (kg)	OFCS	OFCD
7 gpm	190 (86)	220 (100)
14 gpm	197 (89)	227 (103)

Model Code

OFCD - 27 - BN 10 - BN 10 - B - A - 14 - G2187

Series

- OFCS = Single Filter System
- OFCD = Dual Filter System

Pneumatic Option

- (omit) = Electric motor (standard)
- P** = **Pneumatic motor only**

Element Length

- 1-09 = One 9" Element Supplied
- 2-09 = Two 9" Elements Supplied (must be same micron rating)
- 3-09 = Three 9" Elements Supplied (must be same micron rating)
- 18 = One 18" Element Supplied
- 27 = One 27" Elements supplied

Filter Media

- BN = Betamicron® Low Collapse
- AM* = Aquamicron® Water Removal
- G = Betamicron GeoSeal®

Filtration Rating (BN only - AM has no rating) (microns)

- 3 } Betamicron® (BN/HC)
- 5 } Absolute Filtration Rating
- 10 } ($\beta_{x(c)} \geq 1000$)
- 20 }

Filter Media (OFCD only)

- BN = Betamicron® Low Collapse
- AM* = Aquamicron® Water Removal
- G = Betamicron GeoSeal®

Filtration Rating (BN only - AM has no rating) (microns) (OFCD only)

- 3 } Betamicron® (BN/HC)
- 5 } Absolute Filtration Rating
- 10 } ($\beta_{x(c)} \geq 1000$)
- 20 }

Seals

- B = Buna N
- V = FPM

Voltage

- (omit) = 115 VAC 60HZ/1Phase
- A = 230 VAC 60HZ/3Phase
- B = 460 VAC 60HZ/3Phase
- C = 220 VAC 50HZ/1Phase
- D = 230 VAC 60HZ/1Phase

Pump Size

- 07 = 7 gpm
- 14 = 14 gpm

Options

- G2185 = for 14 gpm unit; up to 2500 SUS fluids; flow reduced to ~10 gpm
- G2187 = for 7 gpm unit; up to 2500 SUS fluids; flow reduced to ~3 gpm
- PC = Hytrax Contamination Monitoring Unit (will work with G2185 option for oils up to 2500SUS)
- CSI = CSI-C-11 Sensor Interface Option for data acquisition (only with PC option)
- CSI-W = CSI-C-11 Sensor Interface Option for data acquisition with AS1008 Water Saturation Sensor (only with PC option)

*Aquamicron media should be in the first filter housing followed by the BN media in the second housing.
For replacement element part numbers, please see Section E - REPLACEMENT ELEMENTS of this catalog.

Model Codes Containing RED are non-standard items – Minimum quantities and longer lead times may apply - Contact HYDAC for information and availability

Dimensions

OFCS Series

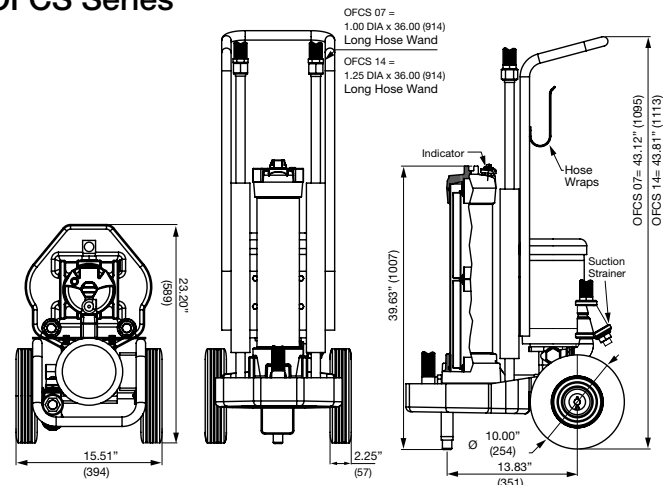

OFCD Series

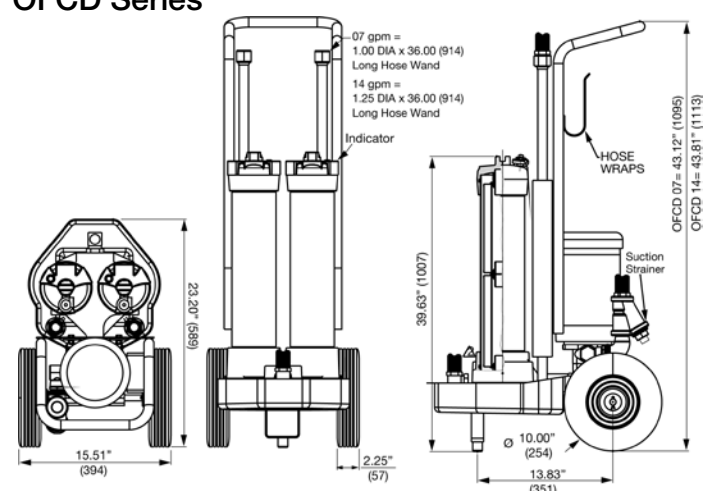

Dimensions are for general information only, all critical dimensions should be verified by requesting a certified print.

OFFLINE FILTRATION SYSTEMS

OFCD-MV Series

Compact Dual Stage Filtration System up to 5,000 SUS



Hydraulic Schematic

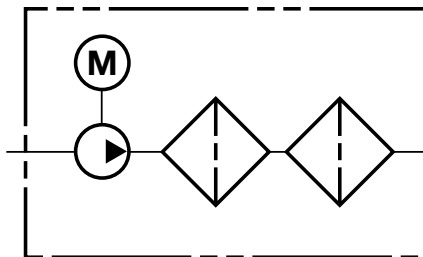

Description

HYDAC's newest addition to the portable filtration carts offers the user the ability to filter up to 5,000 SUS fluids.

The OFCD-MV is a compact, self-contained filtration system equipped with high efficiency, high capacity elements capable of removing particulate contamination and/or water quickly, conveniently and economically. It is perfect for cleaning up existing systems as well as for prefiltering new fluids, since new fluids often have contamination levels significantly higher than that recommended for most hydraulic systems.

The OFCD-MV dual filtration unit can be used to remove both water and particulate contamination or for staged particulate contamination removal.

Features

- Ability to filter fluids having a viscosity up to 5,000 SUS
- Top-ported filter provides easy element service
- Ten-foot hose and extension tubes included

Applications

- Supplementing continuous filtration by the system's filters
- Cleaning up a hydraulic system following component replacement
- Filtering new fluid before it is put into service
- Transferring fluid from storage tanks and drums to system reservoirs

Technical Specifications

Flow Rating	up to 10 gpm (37.9 lpm)
Maximum Viscosity	up to 5,000 SUS (1079 cSt)
Hose Pressure Rating	30 psig (2.0 bar) @ 150°F (65°C) Full vacuum @ 150°F (65°C)
Maximum Operating Temperature	-20° to 150°F (-29° to 65°C)
Bypass Valve Setting	Cracking: 30 psi (2 bar)
Material	Manifold and Cap: Cast Aluminum Element case: Steel
Compatibility	All petroleum based hydraulic fluid. Contact factory for use with other fluids
Motor	1.0HP 110VAC/60HZ TEFC (6gpm) 1.5HP 110VAC/60HZ (10gpm)

Model Code

OFCD-MV - 18 - G 10 - G 10 - V - 6

Series

OFCD-MV = Dual Filter System

Element Length

18 = One 18" element supplied per housing

Filter Media

G = Betamicon GeoSeal®

GAM* = Aquamicon® Water Removal

Filtration Rating (G only - GAM has no rating) (microns)

3 } Betamicon® (BN/HC)
 5 } Absolute Filtration Rating
 10 } ($\beta_{x(c)} \geq 1000$)
 20 }

Filter Media

G = Betamicon GeoSeal®

GAM* = Aquamicon® Water Removal

Filtration Rating (G only - GAM has no rating) (microns)

3 } Betamicon® (BN/HC)
 5 } Absolute Filtration Rating
 10 } ($\beta_{x(c)} \geq 1000$)
 20 }

Seals

V = FPM

Pump Size (gpm)

6 = 6 gpm

10 = 10 gpm

*Aquamicon media should be in the first filter housing followed by the Betamicon media in the second housing. For replacement element part numbers, please see Section E - REPLACEMENT ELEMENTS of this catalog.

Model Codes Containing RED are non-standard items - Minimum quantities and longer lead times may apply - Contact HYDAC for information and availability

Dimensions

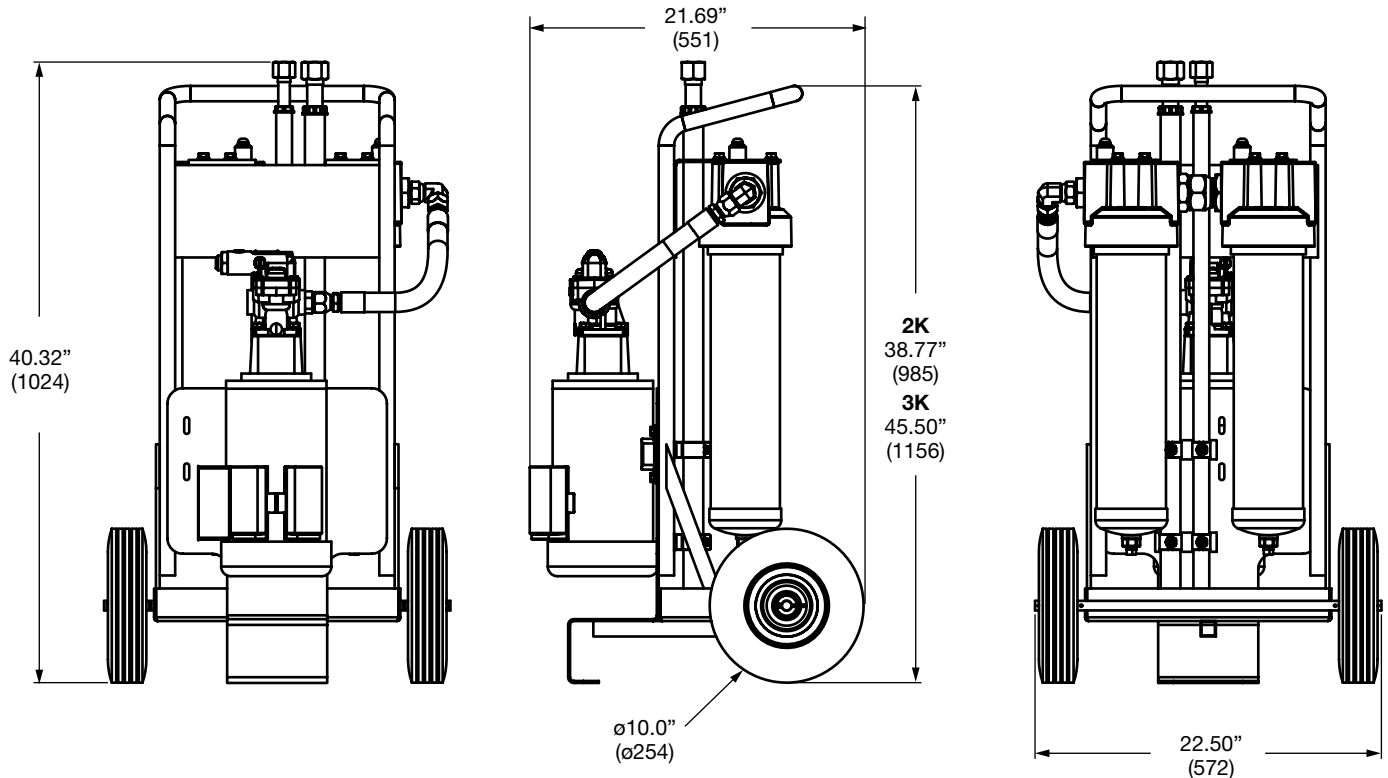

Dimensions are for general information only, all critical dimensions should be verified by requesting a certified print.

OFFLINE FILTRATION SYSTEMS

OFCD-HV Series

Compact Dual Stage Filtration System for High Viscosity



Hydraulic Schematic

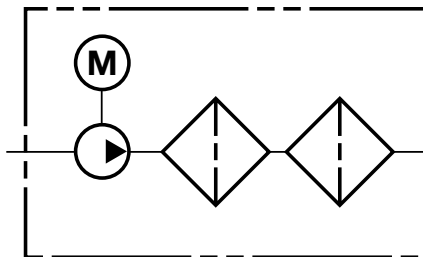

Description

A portable filtration cart that offers the user the ability to filter high viscosity fluids.

The OFCD-HV is a compact, self-contained filtration system equipped with high efficiency, high capacity elements capable of removing particulate contamination and/or water quickly, conveniently and economically. It is perfect for cleaning up existing systems as well as for prefiltering new fluids, since new fluids often have contamination levels significantly higher than that recommended for most hydraulic systems.

The OFCD-HV dual filtration unit can be used to remove both water and particulate contamination or for staged particulate contamination removal. Additional features include a modular base that eliminates hoses and fittings between components, a drip pan and easier element servicing.

Features

- An integrated lifting eye option for lifting the OFCD-HV
- Ability to filter fluids having a viscosity up to 15,000 SUS
- Base-ported filter provides easy element service from the top cap
- Ten-foot hose and extension tubes included
- Dip pan catches oil before it falls to the ground

Applications

- Cleaning high viscosity fluids used in wind applications
- Supplementing continuous filtration by the system's filters
- Cleaning up a hydraulic system following component replacement
- Filtering new fluid before it is put into service
- Transferring fluid from storage tanks and drums to system reservoirs

Technical Specifications

Flow Rating	Maximum 3 gpm (11.4 lpm)
Maximum Viscosity	15,000 SUS (3236 cSt)
Hose Pressure Rating	30 psig (2.0 bar) @ 150°F (65°C) Full vacuum @ 150°F (65°C)
Maximum Operating Temperature	-20° to 150°F (-29° to 65°C)
Bypass Valve Setting	Cracking: 40 psi (2.8 bar)
Material	Manifold and Cap: Cast Aluminum Element case: Steel
Compatibility	All petroleum based hydraulic fluid. Contact factory for use with other fluids
Motor	115V AC Single phase, 1.5 HP

Model Code

OFCD-HV - 27 - BN 10 - BN 10 - B - G2502

Series

OFCD-HV = Dual Filter System

Element Length

18 = One 18" element supplied per housing
 27 = One 27" elements supplied per housing

Filter Media

BN = Betamicon® Low Collapse
 AM* = Aquamicon® Water Removal
 G = Betamicon GeoSeal®

Filtration Rating (BN only - AM has no rating) (microns)

3 } Betamicon® (BN/HC)
 5 } Absolute Filtration Rating
 10 } ($\beta_{x(c)} \geq 1000$)
 20 }

Filter Media

BN = Betamicon® Low Collapse
 AM* = Aquamicon® Water Removal

Filtration Rating (BN only - AM has no rating) (microns)

3 } Betamicon® (BN/HC)
 5 } Absolute Filtration Rating
 10 } ($\beta_{x(c)} \geq 1000$)
 20 }

Seals

B = Buna N
 V = FPM

Options

G2502 = for fluids up to 15,000 SUS at 3 gpm
 G2538 = for fluids up to 15,000 SUS at 3 gpm, integrated, balanced lifting eye

*Aquamicon media should be in the first filter housing followed by the BN media in the second housing.
 For replacement element part numbers, please see Section E - REPLACEMENT ELEMENTS of this catalog.

Dimensions

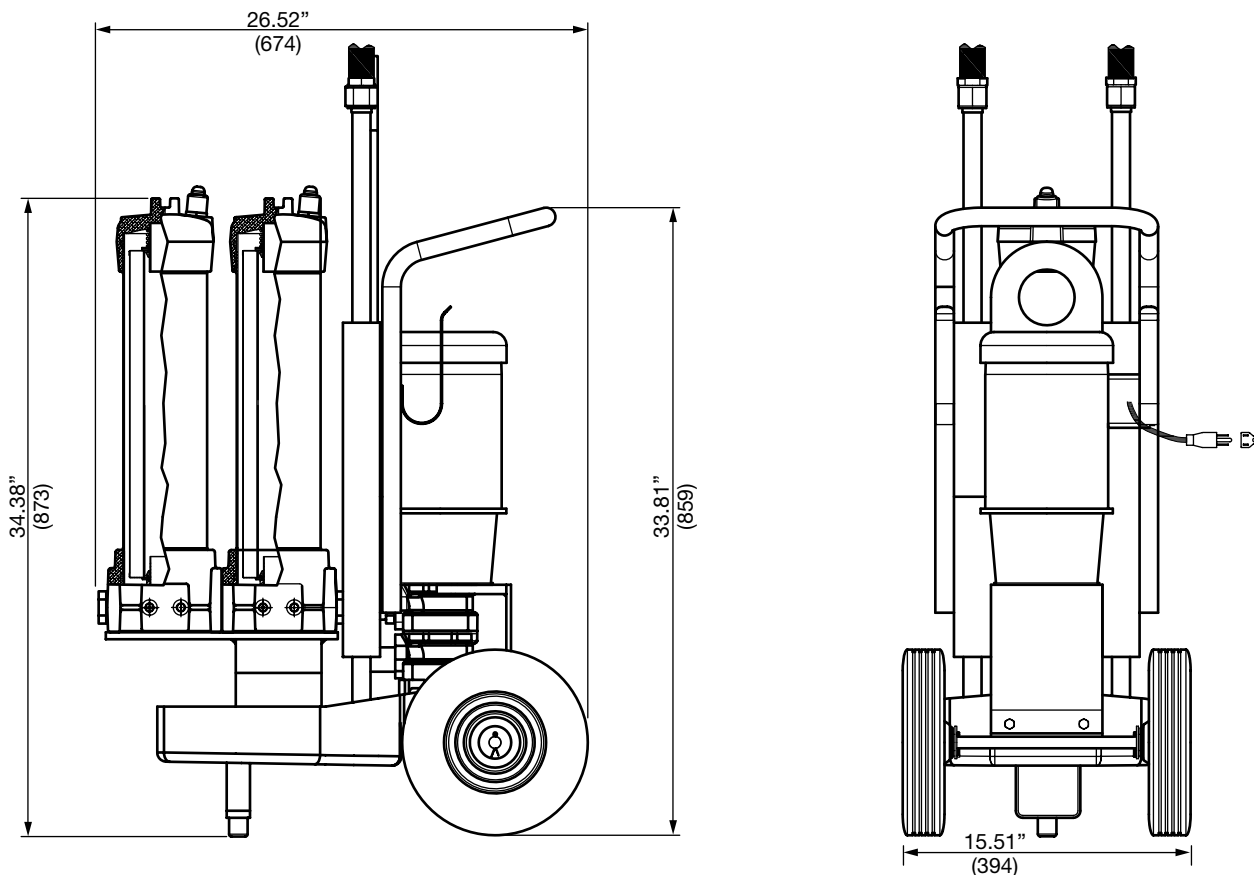

Dimensions are for general information only, all critical dimensions should be verified by requesting a certified print.

OFFLINE FILTRATION SYSTEMS

OFS Series

Filtration Station



Description

The HYDAC Filtration System (OFS) is capable of flushing, filtering, and monitoring ISO cleanliness with user-defined, automatic features.

The OFS is designed to transfer fluid through two filters in series for staged particulate or water/particulate removal. Both filters are top-loading and include element indicators in the cap. A particle monitor reads samples from the pump discharge and displays ISO contamination codes on the control panel. The monitor allows the user to input the desired ISO cleanliness codes for the fluid. In auto mode, the system will run until the cleanliness codes are reached. Upon reaching the codes, the pump will stop and the cycle complete light will come on. When in manual mode, the system will run continuously and display the ISO codes. A water sensor is included for providing the water saturation of the fluid, both displayed on the control panel.

Features

- Real time monitoring of ISO cleanliness classes
- Automatic shutdown when user defined ISO codes are reached
- USB port allows the ISO code data to be downloaded for further processing and/or printing
- 30 mesh suction strainer and 230 micron filter and included to protect the particle monitor from clogging
- The AS 1000 allows real-time water saturation and temperature values of the fluid to be displayed
- Bypass valve so cart can be used as a transfer cart
- Single lift point
- Plastic removable drip pan

Applications

- **In-Plant Service** – Filter to desired cleanliness levels and extend component life
- **Mobile Dealer Networks** – Aid in certified re-builds, service maintenance contracts and total maintenance & repair programs
- **Original Equipment Manufacturer** – Filter to required roll-off cleanliness levels
- **Lubricant Reclamation/Recycling** – Clean oil to extend oil life and reduce hazardous waste

Technical Specifications

Flow Rating	9 gpm (34 lpm) (AC option); 3-8 gpm (11.4 to 30.3 lpm) (DC option)
Motor	1 1/2 HP, 115/220VAC motor (AC option) 1 HP, 90 V DC variable speed (DC option)
Viscosity	1000 SUS (230cSt)
Operating Temperature	-20° F to 150° F (-29° C to 65° C)
Bypass Valve Setting	Cracking: 30 psi (2 bar) x 2
Compatibility	All petroleum based hydraulic fluid. (Contact factory for use with other fluids.)
Element Change Clearance	18" or 27" (depending on model configuration)
Weight	245 lbs (112 kg)

Model Code

OFS - A - 1 - 27 - BN - 10 - BN - 01 - V - 9 - W

Series	OFS	=	Filtration Station
Voltage	A	=	120 VAC 60 Hz 1 Ph
	B	=	220 VAC 60 Hz 1 Ph
	C	=	220 VAC 50 Hz 1 Ph
	<i>(A plug is not provided for these options.)</i>		
Number of Elements	<i>(18" and 27" housings only)</i>		
	1	=	Element length must be either 18" or 27"
	2	=	Two 9" elements per 18" housing
	3	=	Three 9" elements per 27" housing
Element Length	<i>(18" and 27" housings only)</i>		
	09	=	Two 9" elements per 18" housing Three 9" elements per 27" housing
	18	=	One 18" element per 18" housing
	27	=	One 27" element per 27" housing
Element Media	BN	=	Betamicon®
	AM*	=	Aquamicon®
Filtration Rating	<i>(BN only - AM has no rating) (microns)</i>		
	01, 03, 05, 10, 25		
Element Media	BN	=	Betamicon®
	AM*	=	Aquamicon®
Filtration Rating	<i>(BN only - AM has no rating) (microns)</i>		
	01, 03, 05, 10, 25		
Seals	V	=	Fluoroelastomer (FPM)
	B	=	Buna N
Pump Size	<i>(gpm)</i>		
	9	=	Fixed Speed Drive, Gear Pump, 9 gpm
	DC	=	Variable Speed Drive, Gear Pump, 3 to 8 gpm
Options	W	=	AS1000 Water Sensor <i>(standard on all units)</i>

*Aquamicon media should be in the first filter housing followed by the BN media in the second housing.
For replacement element part numbers, please see Section E - REPLACEMENT ELEMENTS of this catalog.

Model Codes Containing RED are non-standard items - Minimum quantities and longer lead times may apply - Contact HYDAC for information and availability

Dimensions

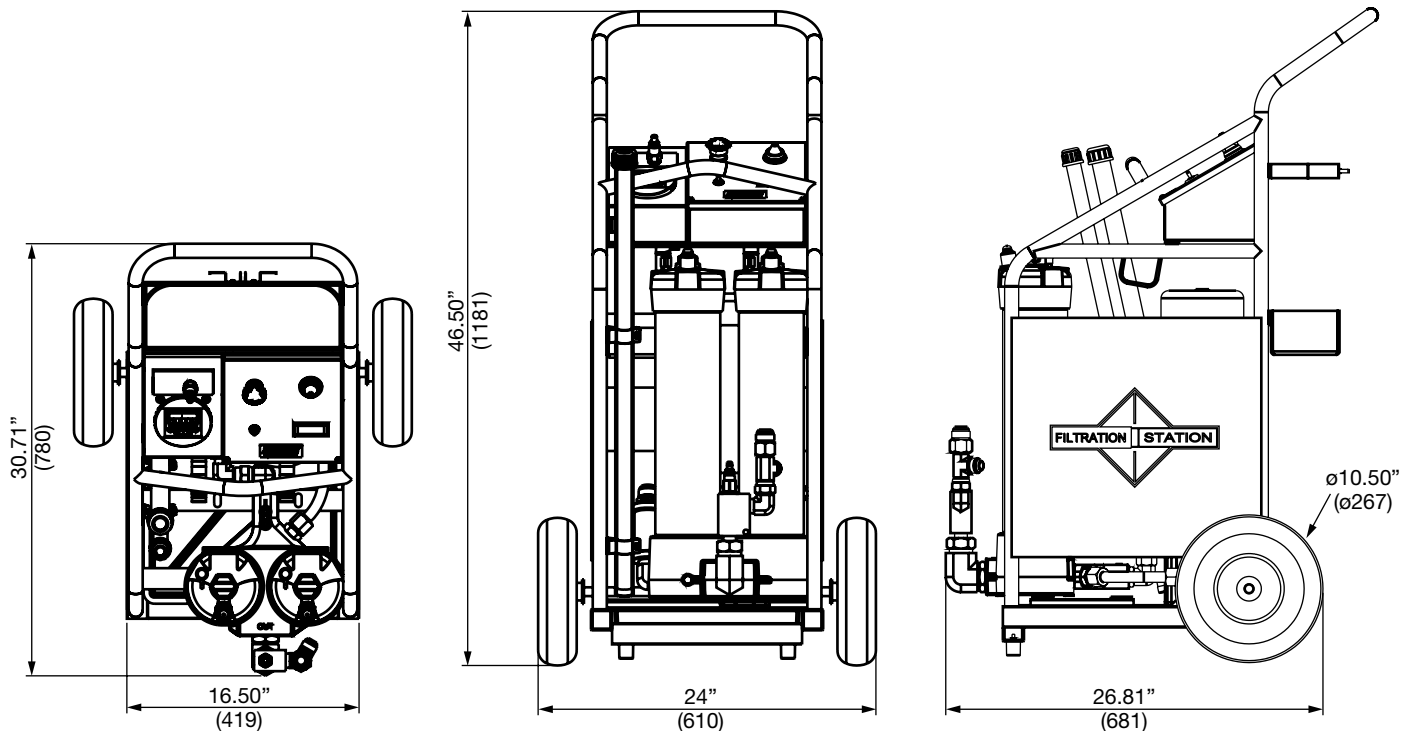

Dimensions are for general information only, all critical dimensions should be verified by requesting a certified print.

OFFLINE FILTRATION SYSTEMS

OFS-AM Series

Filtration Station for Asset Management



Asset Management

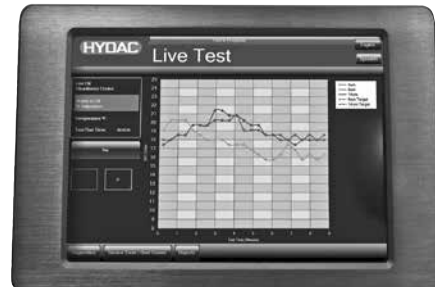

- Real Time data displays cleanliness and water saturation
- Selectable ISO target levels
- Only 3 entry fields needed to start the system and record data

Description

The Offline Filtration Station for Asset Management (OFS-AM) is a complete fluid management system designed to manage fluid cleanliness, so that the greatest return of that asset is achieved. The OFS-AM is an all-in one system that monitors your fluid condition, filters out contaminants and tracks all the necessary data needed for trend analysis and record keeping by asset number or name. The on-board ruggedized PC records the ISO code and water saturation level, provides a graphical display of the data in real time and shuts down when the selected cleanliness level is reached. Each asset file created automatically is separately labeled and summarized to quickly inform maintenance on the condition of the fluid, and each run of the fluid is logged by date and time, providing a complete history of the equipment's fluid.

Features

- Complete tracking of hydraulic fluid conditions by equipment name
- Provides automatic record-keeping, trending and analysis of the fluid condition per fluid power system asset
- Ideal for managing multiple equipment assets
- Automatically shuts down when the selected ISO cleanliness is reached
- Dual staged filters for both water and/or particulate contamination removal
- Bypass valve allows the OFS-AM to be used as a transfer cart

Applications

- **In-Plant Service** – Filter to desired cleanliness levels and extend component life
- **Mobile Dealer Networks** – Aid in certified re-builds, service maintenance contracts and total maintenance & repair programs

Technical Specifications

Flow Rating	5 gpm (19 L/min)
Motor	1.5 HP - 15 FLA at 120 volts AC
Viscosity	up to 1000 SUS (216 cSt)
Operating Temp.	-20°F to 150°F (-29°C to 65°C)
Bypass Valve Setting	Cracking: 30 psi (2 bar) x 2
Compatibility	All petroleum based hydraulic fluid compatible with Viton®
Weight	200 lbs (90.7 kg) approx.
Dimensions	26.6" x 25.25" x 50.0"(675 x 641 x 1270 mm)

Model Code

OFS-AM - 1 - 18 G10 - G05

Series

OFS-AM = Filtration Station for Asset Management

Number of Elements

1 = Element length must be either 18" or 27"

Element Length

18 = One 18" element supplied per housing

27 = One 27" element supplied per housing

Element Size (BN only - AM has no rating) (microns)

G03, G05, G10 = Betamicron GeoSeal® Absolute Filtration Rating ($\beta_{x(e)} \geq 1000$)

GAM* = Aquamicron GeoSeal® Water Removal

Element Size (BN only - AM has no rating) (microns)

G03, G05, G10 = Betamicron GeoSeal® Absolute Filtration Rating ($\beta_{x(e)} \geq 1000$)

GAM* = Aquamicron GeoSeal® Water Removal

*Aquamicron media should be in the first filter housing followed by the BN media in the second housing.
For replacement element part numbers, please see Section E - REPLACEMENT ELEMENTS of this catalog.

Dimensions

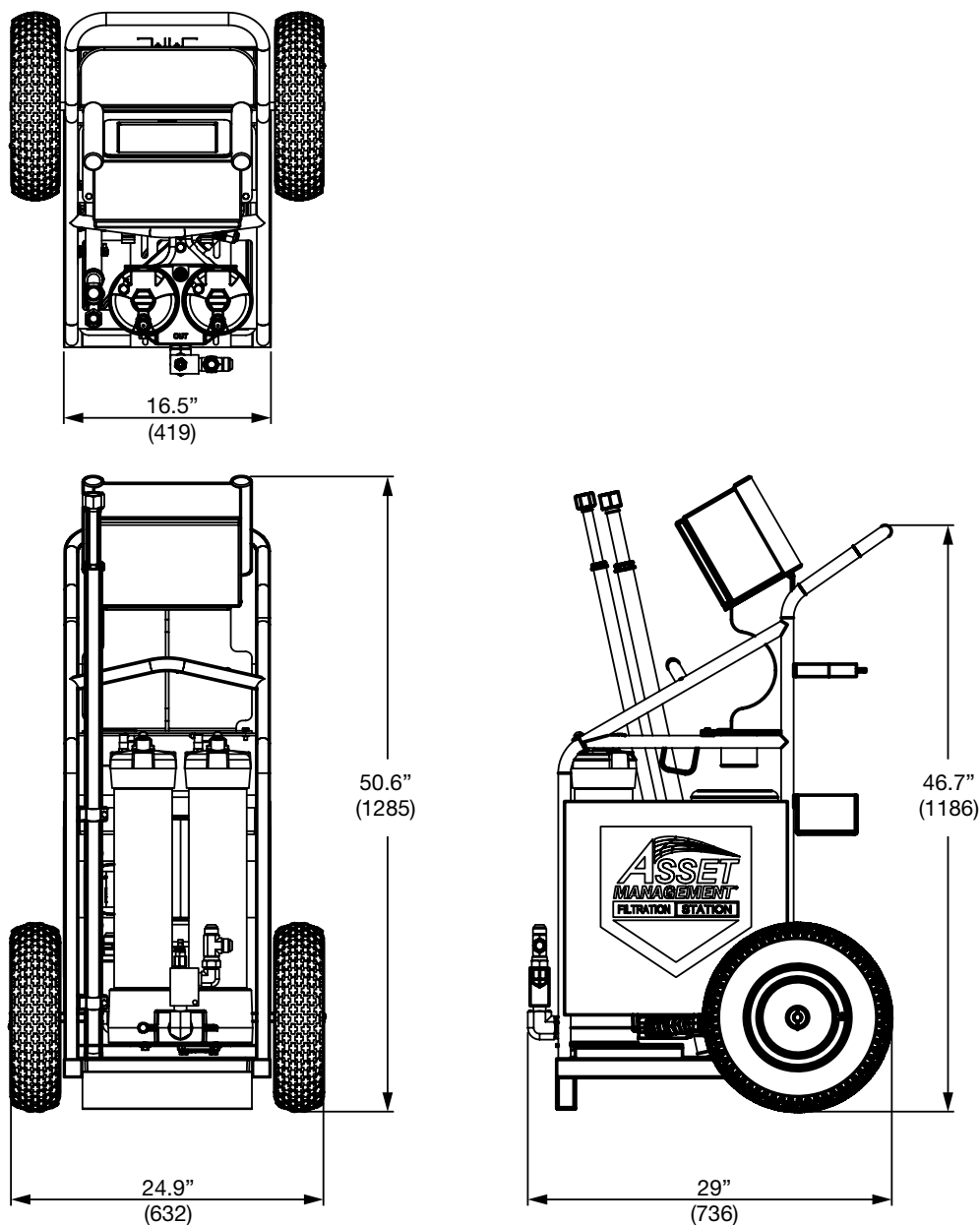

Dimensions are for general information only, all critical dimensions should be verified by requesting a certified print.

OFFLINE FILTRATION SYSTEMS

OF5HS & OF5HD Series

Single & Dual Stage Kidney Loop Systems



OF5HD



OF5HS

Description

HYDAC's off-line Kidney Loop System is a stationary version of the mobile filtration system (OFCS & OFCD). It is a compact, self-contained filtration system equipped with high efficiency, high capacity elements capable of removing particulate contamination and/or water quickly, conveniently and economically.

HY-TRAX manual fluid sampling system: HYDAC now offers the HY-TRAX manual fluid sampling system as an additional option allowing for real-time fluid condition monitoring. ISO particle counts are visually displayed on the CS1000. Users will now know when they have reached their desired ISO contamination levels.

CSI-C-11: HYDAC also offers the CSI-C-11 Communication Interface for WLAN or LAN transmission of data and data storage capabilities.

Features

- Modular base eliminates connections between components and minimizes leakage
- Base-ported filter provides easy element service from the top cap
- Visual Dirt Alarm® indicates when filter element needs to be changed
- Two 7/16 – 20 UNF sampling port included on all models

Applications

- Supplementing in-line filtration by system filters when adequate turnover cannot be attained
- Large volume systems requiring multiple filters in different locations
- Cleaning up a hydraulic system following component replacement

Technical Specifications

Flow Rating	7 gpm max (26.5 lpm) or 14 gpm max (53 lpm)
Maximum Viscosity	1000 SUS (216 cSt) Higher viscosity version available.
Maximum Operating Temperature	-20° to 150°F (-29° to 65°C)
Bypass Valve Setting	Cracking: 30 psi (2 bar)
Material	Manifold and cap: Cast aluminum Element case: Steel
Compatibility	All petroleum based hydraulic fluid. Contact factory for use with other fluids.
Motor	115 V AC Single phase 3/4 hp (7 gpm) or 1-1/2 hp (14 gpm)
Weight	OF5HS-1: 101 lb (45.9 kg) OF5HS-2: 112 lb (50.9 kg) OF5HS-3: 123 lb (55.9 kg) OF5HD-1: 117 lb (53.2 kg) OF5HD-2: 139 lb (63.2 kg) OF5HD-3: 161 lb (73.2 kg)

Model Code

OF5HD - 27 - BN 10 - BN 10 - B - A - 14 -

Series

- OF5HS = Single Filter System
- OF5HD = Dual Filter System

Element Length

- 1-09 = One 9" Element Supplied
- 2-09 = Two 9" Elements Supplied (*must be same micron rating*)
- 3-09 = Three 9" Elements Supplied (*must be same micron rating*)
- 18 = One 18" Element Supplied
- 27 = One 27" Element supplied

Element Media

- BN = Betamicon® AM* = Aquamicon® G = Betamicon GeoSeal®

Filtration Rating (BN only - AM has no rating) (microns)

- 3, 5, 10, 25

Element Media (OF5HD only)

- BN = Betamicon® AM* = Aquamicon® G = Betamicon GeoSeal®

Filtration Rating (BN only - AM has no rating) (microns)

- 3, 5, 10, 25

Seals

- B = Buna N V = FPM

Voltage

- (omit) = 115 VAC 60HZ/1Phase
- A = 230 VAC 60HZ/3Phase C = 220 VAC 50HZ/1Phase
- B = 460 VAC 60HZ/3Phase D = 230 VAC 60HZ/1Phase

Pump Size

- 07 = 7 gpm 14 = 14 gpm

Options

- G2185 = for 14 gpm unit; up to 2500 SUS fluids; flow reduced to ~10 gpm
- G2187 = for 7 gpm unit; up to 2500 SUS fluids; flow reduced to ~3 gpm
- PC = HyTRAX Contamination Monitoring System
- CSI = CSI-C-11 Sensor Interface Option for data acquisition (only with PC option)
- CSI-W = CSI-C-11 Sensor Interface Option for data acquisition with AS1008 Water Saturation Sensor (only with PC option)

NOTE: Contact factory if EPR seals are required.

*Aquamicon media should be in the first filter housing followed by the BN media in the second housing.

For replacement element part numbers, please see Section E - REPLACEMENT ELEMENTS of this catalog.

Model Codes Containing RED are non-standard items - Minimum quantities and longer lead times may apply - Contact HYDAC for information and availability.

Dimensions

OF5HS

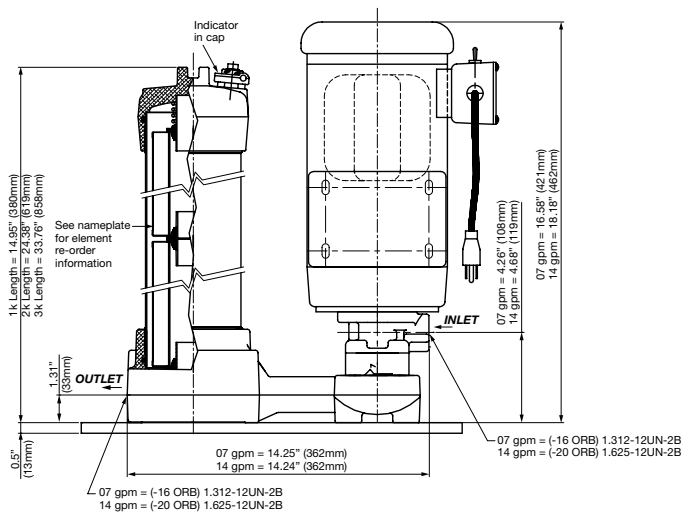

OF5HD

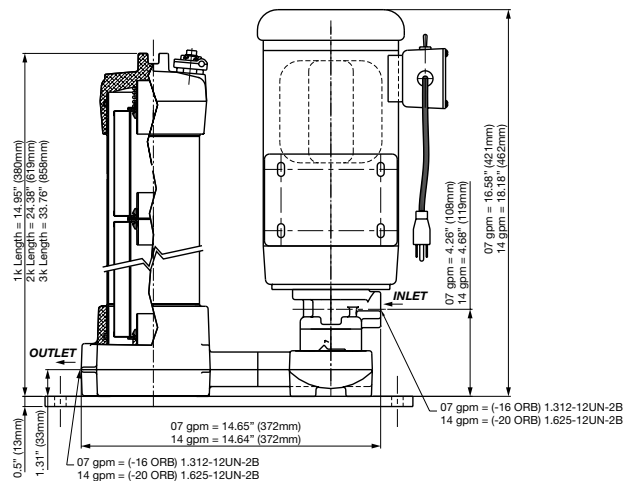

Dimensions are for general information only, all critical dimensions should be verified by requesting a certified print.

OFFLINE FILTRATION SYSTEMS

MCO Series

Fail-Safe In-Line Mechanical Clean Oil Dispensing Filter



Hydraulic Schematic

Normal Operation

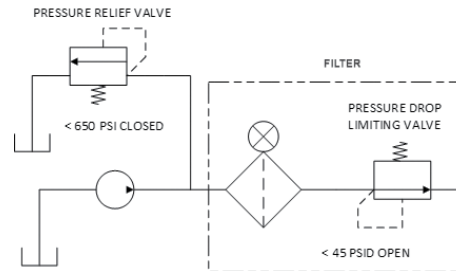

"Bypass" Operation

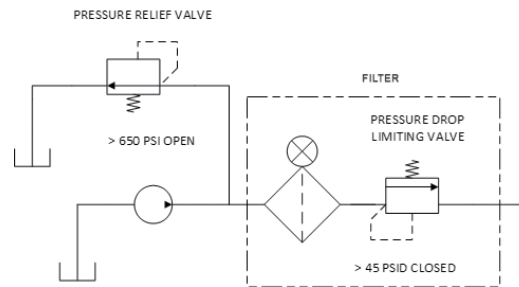

Description

- Fail-safe In-Line Mechanical Clean Oil Dispensing Filter rated for 900 psi and 30 gpm
- Ideal for dispensing applications where clean fluid delivery is a must
- Dispensed fluid is filtered or it is returned to the tank
- Field proven to deliver ISO cleanliness levels of 18/15/13 or better in a single pass
- Series filtration with MCO2 and MCO3 filters

Features

- Housings incorporate a non-bypassing but low cost 150 psi beta $X \geq 1000$ rated element
- Low element cost is achieved through the use of a unique proportional valve that, when used with an external relief valve, redirects the flow back to the tank as element DP increases
- As the element loads, the element service life indicator, located on the housing, **indicates** that service is required before the fluid flow begins to return to tank. Unfiltered "dirty" oil cannot pass the filter even if the service life indicator is ignored.
- Fluid Cleanliness Sampling Ports provided for proof of filtration into the system being filled
- Easy to install and designed with top service for easy element service

Applications

- Mobile equipment
- Cleaning up a hydraulic system following component replacement
- Filtering new fluid before it is put into service
- Transferring fluid from storage tanks and drums to system reservoirs

Technical Specifications

Flow Rating	Up to 30 gpm (113 L/min) for 150 SUS (32 cSt) fluids
Max. Operating Pressure	900 psi (60 bar)
Min. Yield Pressure	3200 psi (220 bar), per NFPA T2.6.1
Rated Fatigue Pressure	750 psi (52 bar) per NFPA T2.6.1-R1-2005
Temp. Range	-20°F to 225°F (-29°C to 107°C)
Bypass Setting	Non-Bypassing System
Porting Head & Cap Element Case	Cast Aluminum Steel
Weight of MCO-1K	21 lbs. (9.5 kg)
Weight of MCO-2K	32 lbs. (14.5 kg)
Weight of MCO-3K	43 lbs. (19.5 kg)
Element Change Clearance	17.50" (445 mm) for KK; 26.5" (673 mm) for 27K

Model Code

		MCO - 3 - 27 - G05 - G03 - G03 - B - S - D5 - RV
Series	MCO = Mechanical Clean Oil Filter System	
Number of Housings	1, 2, 3	
Element Length	27	
Element Micron Rating First Filter (MCO1, MCO2, MCO3)		
G01	= 1 µm Z-Media® (synthetic)	
G03	= 3 µm Z-Media® (synthetic)	
G05	= 5 µm Z-Media® (synthetic)	
G010	= 10 µm Z-Media® (synthetic)	
G025	= 25 µm Z-Media® (synthetic)	
Element Micron Rating Second Filter (MCO2, MCO3)		
G01	= 1 µm Z-Media® (synthetic)	
G03	= 3 µm Z-Media® (synthetic)	
G05	= 5 µm Z-Media® (synthetic)	
G10	= 10 µm Z-Media® (synthetic)	
G25	= 25 µm Z-Media® (synthetic)	
Element Micron Rating Third Filter (MCO3 Only)		
G01	= 1 µm Z-Media® (synthetic)	
G03	= 3 µm Z-Media® (synthetic)	
G05	= 5 µm Z-Media® (synthetic)	
G10	= 10 µm Z-Media® (synthetic)	
G25	= 25 µm Z-Media® (synthetic)	
Seal Material	V = Viton®	
Porting	S = SAE 20 P = 1 1/4 NPTF	
Indicator Options (Only for outlet block)	D5 = Visual Pop-up MS10 = Electrical with DIN Connector (male end only) MS11 = Electrical with 12ft. 4-conductor wire MS14 = Supplied with 5-pin Brad Harrison make connector and light (male end)	
Relief Valve	Omit = Customer Supplied RV = HYDAC Relief Valve (set at 650 psi)*	

*The "RV" option is supplied as a loose item. Users have to install the relief valve within their Hydraulic System.

Application Circuit

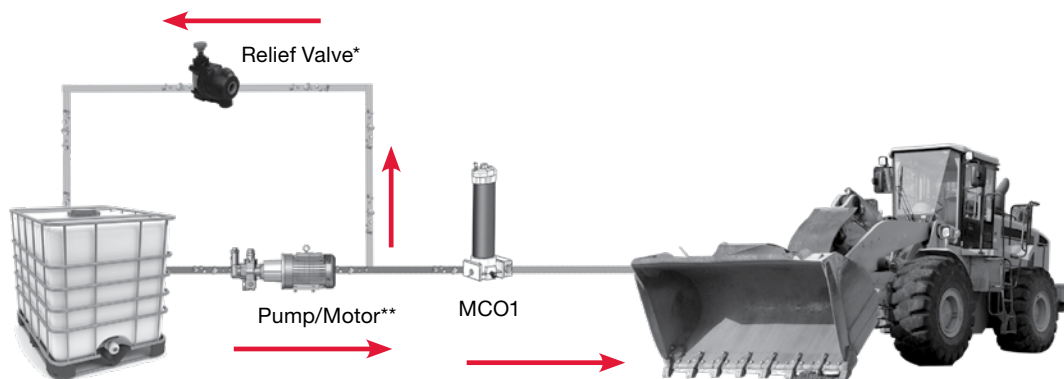

* Product not included in base model pricing.

** Product is customer supplied.

OFFLINE FILTRATION SYSTEMS

OF5HD-HV Framed Series

Compact Dual Stage Filtration System for High Viscosity



Hydraulic Schematic

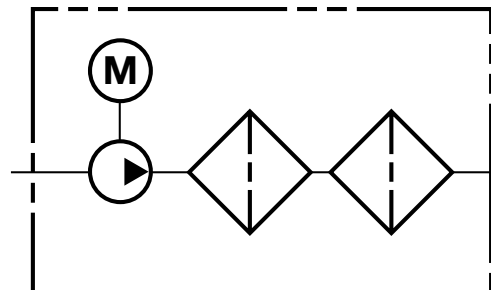

Description

HYDAC's newest addition to the off-line kidney loop family offers the user the ability to filter high viscosity fluids - up to 15,000 SUS.

The OF5HD-HV is a compact, self-contained filtration system equipped with high efficiency, high capacity elements capable of removing particulate contamination and/or water quickly, conveniently and economically. It is perfect for cleaning up existing systems as well as for prefiltering new fluids, since new fluids often have contamination levels significantly higher than that recommended for most hydraulic systems.

The OF5HD-HV dual filtration unit can be used to remove both water and particulate contamination or for staged particulate contamination removal. Additional features include a modular base that eliminates hoses and fittings between components with easy to change element design.

Features

- Rugged, protective frame with integrated lifting eyes for lifting the filter skid via crane or hoist
- Ability to filter fluids having a viscosity up to 15,000 SUS
- Modular base eliminates hoses between components and minimizes leakage
- Base-ported filter provides easy element service from the top cap
- 18-inch housing is standard

Applications

- Compact design in protective frame allows for easy transport uptower in wind applications
- Supplementing continuous filtration by the system's filters
- Cleaning up a hydraulic system following component replacement
- Filtering new fluid before it is put into service
- Transferring fluid from storage tanks and drums to system reservoirs

Technical Specifications

Flow Rating	Maximum 3 gpm (11.4 lpm)
Maximum Viscosity	15,000 SUS (2150 cSt)
Maximum Operating Temperature	-20° to 150°F (-29° to 65°C)
Bypass Valve Setting	Cracking: 40 psi (2.8 bar)
Material	Manifold and Cap: Cast Aluminum Element case: Steel Protective Frame: Tubular Steel
Compatibility	All petroleum based hydraulic fluid. Contact factory for use with other fluids
Motor	115V AC Single phase, 1.5 HP

Model Code

OF5HD-HV - 18 - G10 - G05 - V - G2820

Series

OF5HD-HV = Dual Filter System

Element Length

18 = One 18" Element supplied per housing

Element Size (BN only - AM has no rating) (microns)

G03, G05, G10 = Betamicon® Absolute Filtration Rating ($\beta_{x(c)} \geq 1000$)

GAM* = Aquamicon® Water Removal

Element Size (BN only - AM has no rating) (microns)

G03, G05, G10 = Betamicon® Absolute Filtration Rating ($\beta_{x(c)} \geq 1000$)

GAM* = Aquamicon® Water Removal

Seals

V = FPM

Options

G2820 = High Viscosity Filter Skid with rugged protective frame

*Aquamicon media should be in the first filter housing followed by the BN media in the second housing.
For replacement element part numbers, please see Section E - REPLACEMENT ELEMENTS of this catalog.

Dimensions

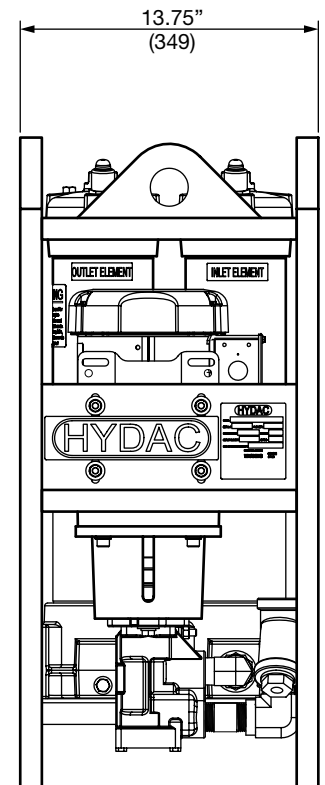
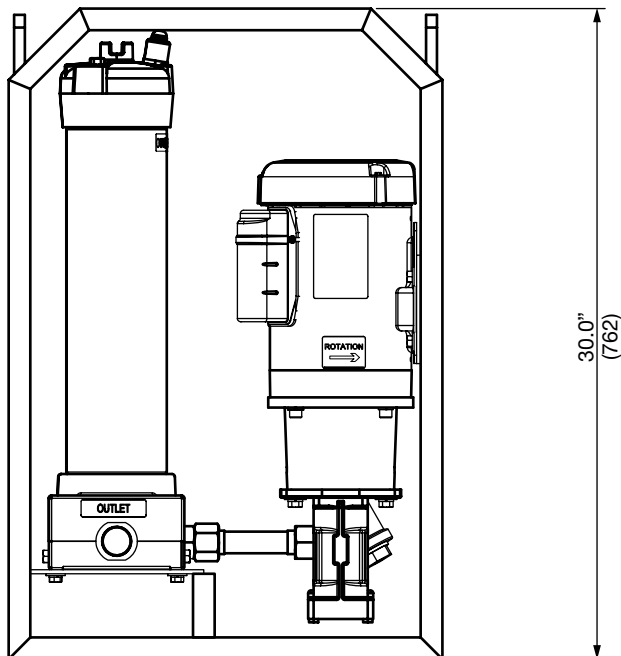
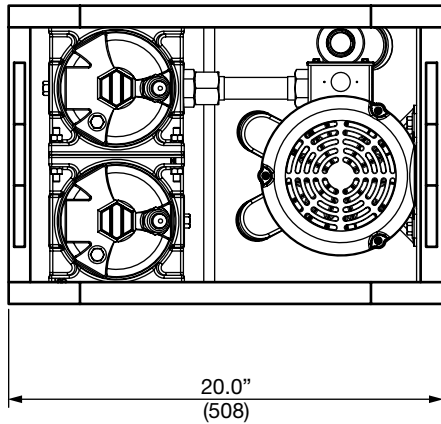

Dimensions are for general information only, all critical dimensions should be verified by requesting a certified print.

OFFLINE FILTRATION SYSTEMS

OFAS & OFAD Series

Single & Dual Stage Air-Operated Kidney Loop Systems



OFAS

Description

HYDAC offers a kidney loop filtration system with a pneumatic motor in place of the standard electric motor. The pneumatic motor offers the same flow capability using the same components, but without the need for an electrical outlet. This provides a major advantage in the application of this unit. With no need for an electrical outlet, it is more portable than the standard electric-motored skids and carts.

Because most trucks and industrial machinery are already equipped with an air compressor, a simple connection to the 1/4" NPT port will easily power the 1.5 HP (or 4.0 HP) motor. At 70 psi, and 2000 rpm, this motor consumes less than 40 cfm (70 cfm for the 4.0HP motor) of compressed air. Because no electricity is used, the pneumatic motor is ideal for working in hazardous environments such as mines.

Performance

Applications

- Supplementing in-line filtration by system filters when adequate turnover cannot be attained
- Large volume systems requiring multiple filters in different locations
- Cleaning up a hydraulic system following component replacement
- Field applications on service trucks

Technical Specifications

Flow Rating	7 gpm (26.5 L/min) max and 14 gpm (53.0 L/min) max
Maximum Viscosity	1000 SUS (216 cSt) Higher viscosity version available. Contact factory for details
Maximum Operating Temperature	-20° to 150°F (-29° to 65°C) For higher temperature applications contact factory.
Bypass Valve Setting	Cracking: 30 psi (2 bar)
Material	Manifold and cap: Cast aluminum Element case: Steel
Compatibility	All petroleum based hydraulic fluid. Contact factory for use with other fluids.
Element Change Clearance	9", 18" or 27" (depending on model configuration)

7 GPM AIR MOTOR
Air Consumption vs. Speed

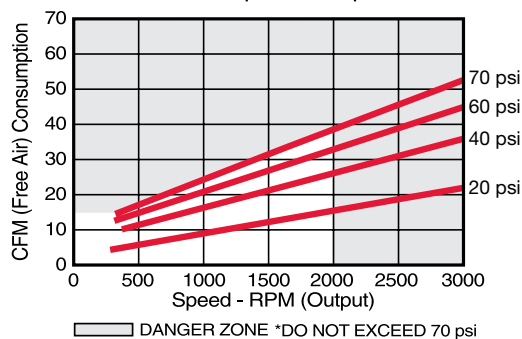

7 GPM AIR MOTOR
Output vs. Speed

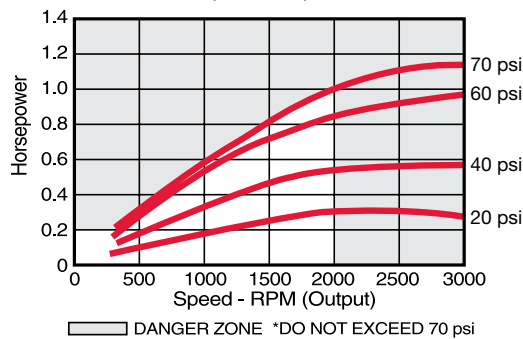

14 GPM AIR MOTOR
Air Consumption vs. Speed

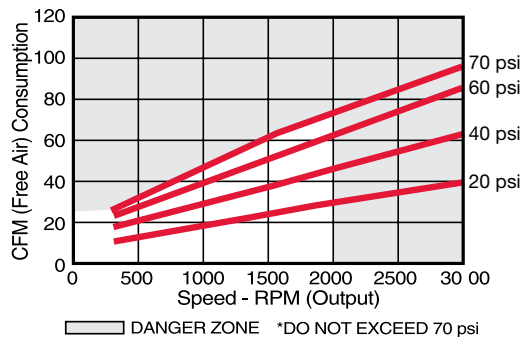

14 GPM AIR MOTOR
Output Power vs. Speed

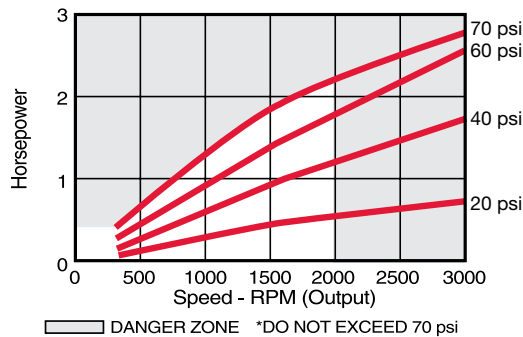

Note: Performance data represents a 4-vane model with no exhaust restriction.

Model Code

LSN - 1 - P4L A - FLND250 10 - BM - 2

Series

LSN = Lube Skid System

Size

1, 2, 3, 4

Pump

P4L = 1.2 gpm, P5L = 1.5 gpm, P6L = 1.9 gpm, P8L = 2.4 gpm, P10L = 3.0 gpm, P12L = 3.8 gpm (Size 1)
 P16L = 4.8 gpm, P20L = 6.0 gpm, P25L = 7.5 gpm (Size 2)
 P32L = 9.6 gpm, P40L = 12.0 gpm, P50L = 15.0 gpm, P63L = 18.9 gpm (Size 3)
 P80L = 24.1 gpm, P100L = 30.2 gpm, P80S = 36.1 gpm, P100S = 45.2 gpm (Size 4)

Motor Voltage

A = 115/230V (1-phase) (Size 1 only)
 B = 208-230/460V (3-phase)
 C = 575V-3 (3-phase)

Filter

FLND 250 (Size 1, 2, and 3)
 FLND 400 (Size 2, 3, and 4)
 LPF 160 (Size 1, 2, and 3)
 LPF 240 (Size 2 and 3)
 LF 660 (Size 4)

Filtration Rating (microns)

3, 5, 10, 20

Clogging Indicator

BM = visual
 C = electric
 D = visual and electric

Clogging Indicator Pressure Setting

2 = 29 psi (2 bar)
 5 = 72.5 psi (5 bar)

For replacement element part numbers, please see Section E - REPLACEMENT ELEMENTS of this catalog.

Dimensions

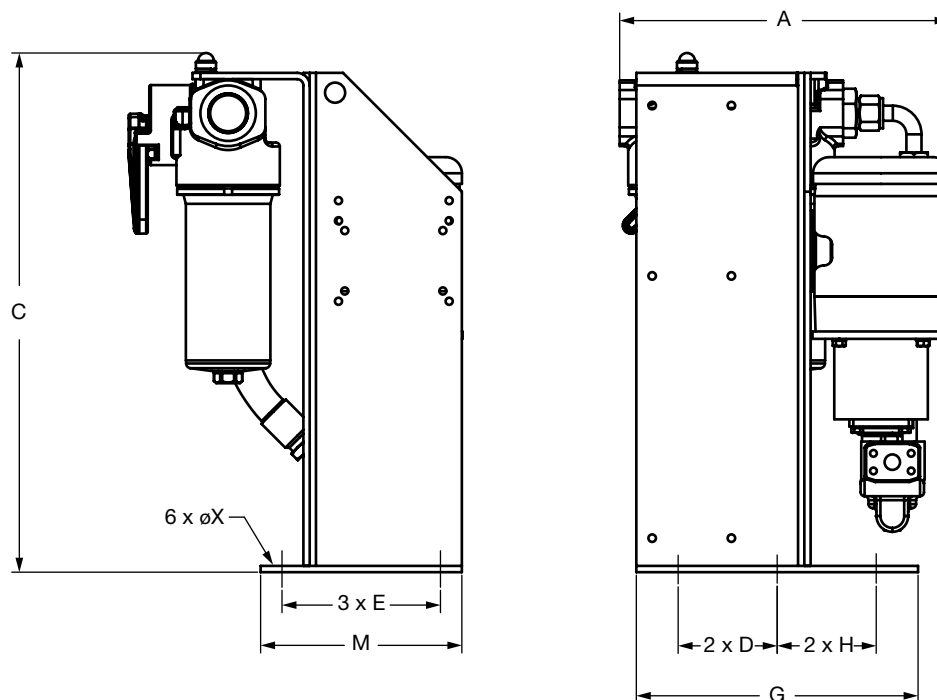

Size	A Max	B Max	C Max	D	E	G	H	M	X
LSN 1	16.45 (417.83)	19.4 (492.76)	27.6 (701.04)	4.92 (124.97)	7.87 (199.9)	11.81 (299.97)	4.92 (124.97)	9.84 (249.94)	.55 (13.97)
LSN 2	20.6 (523.24)	21.5 (546.1)	28 (711.2)	6 (152.4)	10 (254)	14 (355.6)	6 (152.4)	12 (304.8)	.55 (13.97)
LSN 3	22.1 (561.34)	24.11 (612.39)	33.61 (853.69)	6.52 (165.61)	13.28 (337.31)	15 (381)	6.52 (165.61)	15.25 (387.35)	.55 (13.97)
LSN 4	24.16 (613.66)	25.77 (654.56)	39.34 (999.24)	5.93 (150.62)	13.28 (337.31)	17 (431.8)	9.07 (230.38)	15.25 (387.35)	.55 (13.97)

Dimensions are for general information only, all critical dimensions should be verified by requesting a certified print.

OFFLINE FILTRATION SYSTEMS

OFX Series

Filter Skids



Single OFX

Description

HYDAC's OFX Series filtration skids are compact, self-contained filtration systems equipped with high efficiency, high capacity elements capable of removing particulate contamination and/or water quickly and economically. They supplement in-line filters whenever the existing filtration is incapable of obtaining the desired ISO cleanliness level.

It is not uncommon for viscosity to be overlooked when specifying an off-line filtration unit. The results of this oversight can severely affect system efficiency and longevity, and render the filtration system useless when high viscosity fluid causes the filter to be in constant bypass. HYDAC considers maximum fluid viscosity, (at the minimum operating temperature) in conjunction with flow to properly size the pump and motor.

Standard OFX Series OFX2 – OFX6 skids include a hydraulic pump, electric motor, single or dual stage filtration, and standard or high-capacity housing(s). Many different component combinations provide the flexibility to match specific system viscosity, flow, and cleanliness requirements. Multiple housing lengths give the option of adding additional dirt holding capacity.

HYDAC's high viscosity OFX Series skids, OFX7 & OFX8, are designed to handle fluids that have a viscosity as high as 25,000 SUS. The skids have 39" long high capacity filters to efficiently clean the viscous fluids. The filters have a high dirt-holding capacity, capable of holding almost 1000 grams of dirt depending on the element. OFX7 & OFX8 Series skids include a pump, motor, high capacity filter, suction strainer, and dirt indicator. Various options can account for specific user needs.

Features

- Protects and extends the life of expensive components
- Minimizes downtime and maintenance costs
- Designed to handle high viscosity oils up to 25,000 SUS (see Skid Selection)
- Many component combinations and variable starter options allow the flexibility to match specific user needs
- Four wheel cart option provides product portability
- Integral drip pan with drain plug
- Sample valves provided at filter base for fluid sampling
- Market leading HYDAC Betamicon® synthetic filtering media provides for quick, efficient clean up with maximum element life

Technical Specifications

Flow Rating	Up to 82 gpm (310 L/min)
Temp. Range	0°F to 180°F (-17°C to 82°C)
Bypass Valve Setting	50 psi (3.5 bar) for skid series OFX2, OFX3, OFX5, OFX7 & OFX8 40 psi (2.8 bar) for skid series OFX6
Fluid Viscosity	Up to 25,000 SUS (see Skid Selection)
Compatibility	All petroleum based hydraulic fluids. Contact HYDAC for use with other fluids, including ester and skydrol
Pump	OFX2, 3, 5, 6: Continuous duty gear pump with integral 150 psi relief. Flow dependent on skid series and motor. (Refer to Pump, Motor & Weight Data table) OFX7-OFX8: Positive displacement rotary screw-pumps.
Motor	Horsepower dependent on skid series and flow. (Refer to Pump, Motor & Weight Data table)
Porting	Dependent on flow. (Refer to Porting Data table)

Skid Selection

Series	Viscosity Range	Filter Housing(s)	Maximum Flow
OFX2	100 - 2000 SUS	(1) High Capacity or Standard Capacity	82 gpm (310 lpm)
OFX3	100 - 5000 SUS	(1) High Capacity or Standard Capacity	37 gpm (140 lpm)
OFX5	100 - 2000 SUS	(2) High Cap. or Stand. Cap. in series	82 gpm (310 lpm)
OFX6	100 - 5000 SUS	(2) High Cap. or Stand. Cap. in series	37 gpm (140 lpm)
OFX7	100 - 25,000 SUS	(1) High Capacity	6 gpm (23 lpm)
OFX8	100 - 25,000 SUS	(2) High Capacity in parallel	30 gpm (114 lpm)

Porting Data

Flow (gpm)	Inlet Port Sizes	Outlet Port Sizes with Standard Capacity Filters	Outlet Port Sizes with High Capacity Filters
06	1" JIC	N/A	1.625-12UN-2B SAE O-Ring Boss
17	1.875-12UN-2B SAE O-Ring Boss	1.625-12UN-2B SAE O-Ring Boss	1.625-12UN-2B SAE O-Ring Boss
30	2" JIC	N/A	1.625-12UN-2B SAE O-Ring Boss
37	2" JIC	1.875-12UN-2B SAE O-Ring Boss	1.875-12UN-2B SAE O-Ring Boss
60	1.5" JIC	2" O-Ring Boss	2" O-Ring Boss
82	2" JIC	1.875-12UN-2B SAE O-Ring Boss	2.500-12UN-2B SAE O-Ring Boss



Dimensions OFX2,3,5,6 Series with the H3 - high capacity housing option

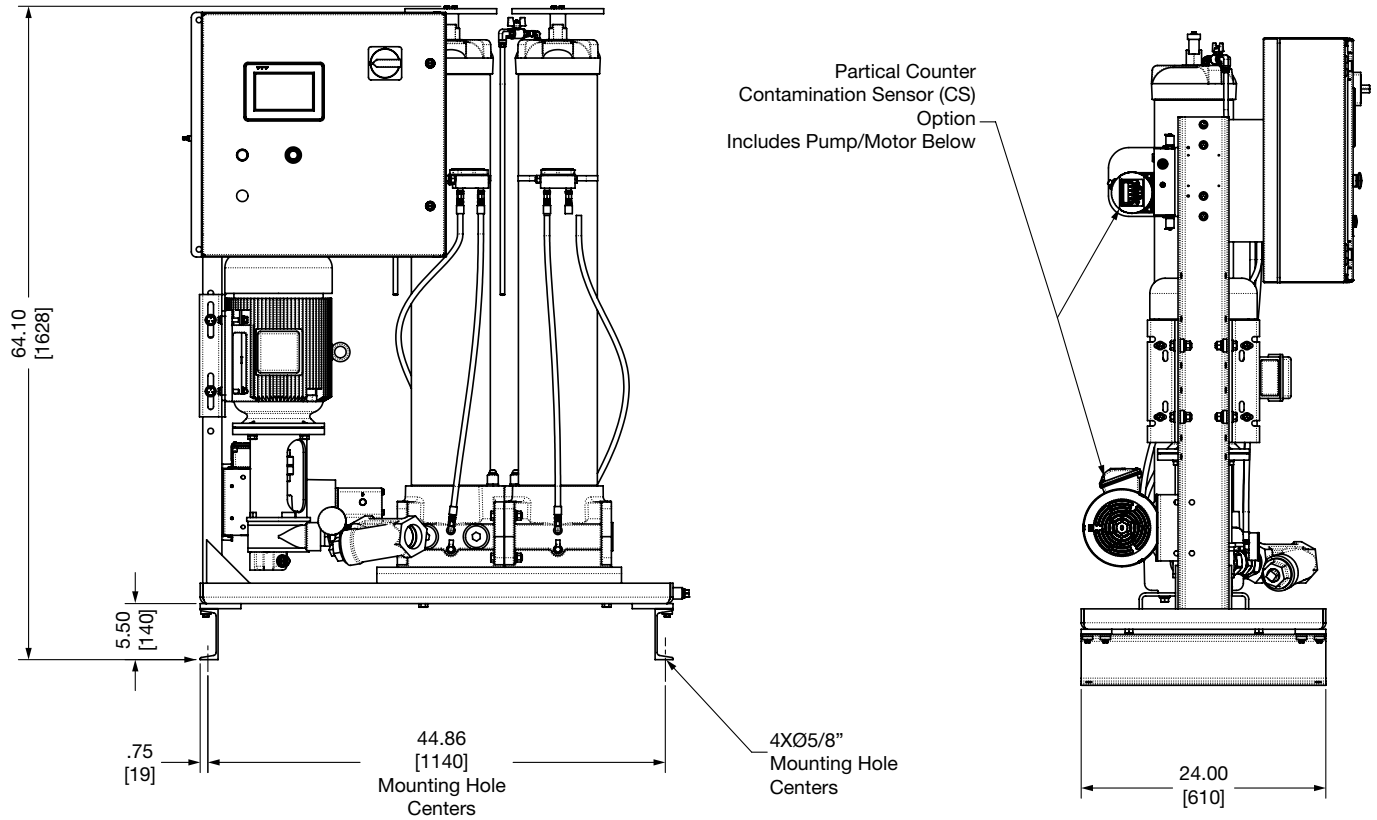

OFX2, 3, 5, 6 with 27" filter housing option

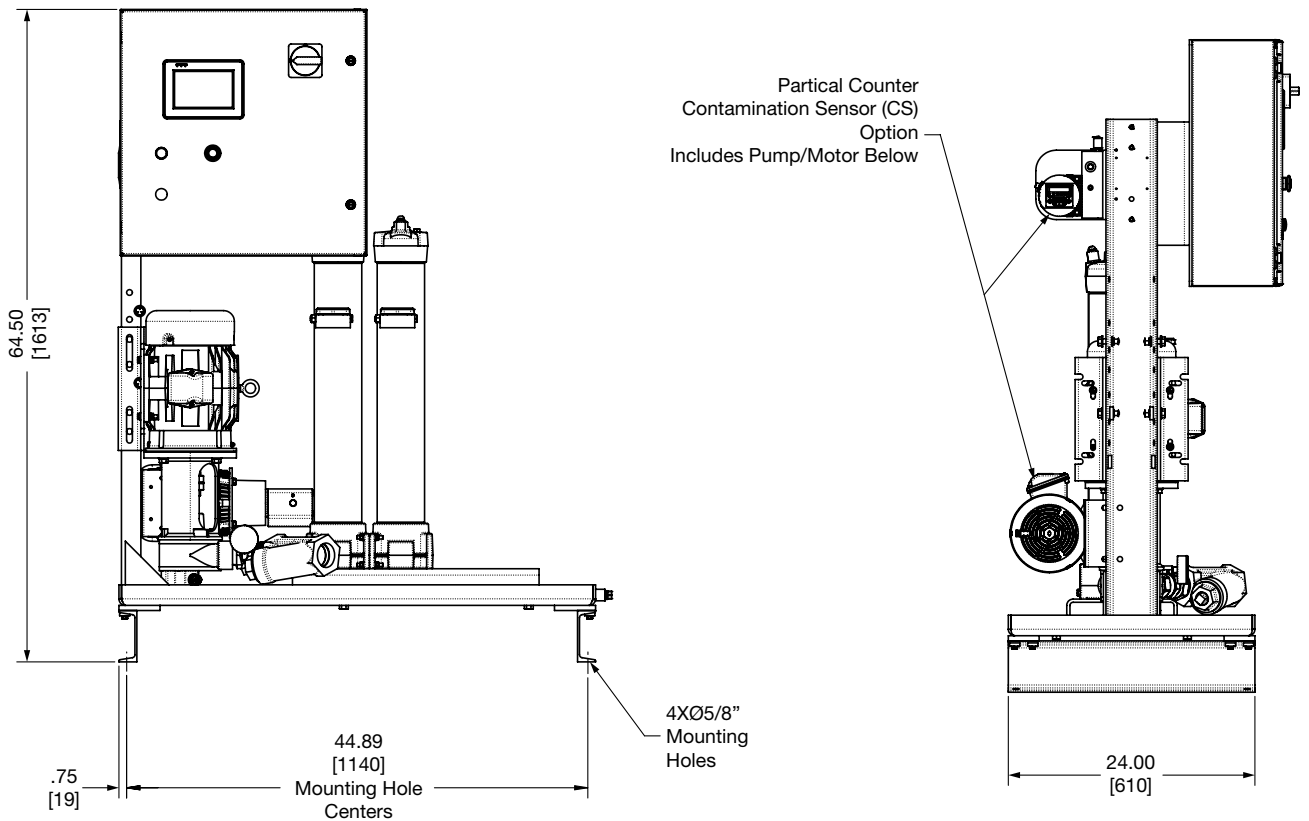

Dimensions are for general information only, all critical dimensions should be verified by requesting a certified print.

OFFLINE FILTRATION SYSTEMS

OLF Compact Series



Features

The OLF Compact filter is designed to be used offline to efficiently and cost effectively filter standard hydraulic oils which are highly contaminated. The OLF Compact is specifically designed to be used on hydraulic systems with a reservoir volume of up to 1000 gallons. The standard filters can be supplied as ready to install offline units complete with motor and pump units as shown or as individual filters.

Benefits

- Lower operating costs
- Extended element service life
- Extended fluid life
- Cleaner, more efficient systems
- Incinerable elements
- Easy installation

Applications

Typical applications include:

- Injection molding machinery
- Machine tools
- Gear boxes
- Mobile equipment
- Filtration of fluids for intermittently operated hydraulic systems and test stands

Technical Specifications

Operating Range	
Viscosity: <i>(see pressure drop curves)</i>	to 700 SUS (150 cSt) (OLF-5) to 3000 SUS (650 cSt) (OLF-5/15) to 10,000 SUS (2160 cSt) (OLF-5/4)
Operating Pressure:	45 psi (3 bar) max up to 87 psi (-0.4 to 6 bar)
Suction Pressure:	11" Hg (-0.4 to 6 bar) max
Inlet Pressure <i>(Model with flow control valve):</i>	145 psi (10 bar) min / 725 psi (50 bar) max
Fluid Temperature:	32° to 175°F (0 to 80°C)
Ambient Temperature:	-4° to 104°F (-20 to 40°C)
Seals:	NBR <i>(standard)</i>
Maximum Flow Rate:	OLF-5 = 1.6 gpm (6.1 lpm) OLF-5/15 = 4.9 gpm (18.6 lpm) OLF-5/4 = 1.3 gpm (4.9 lpm)
Fluids	Standard Mineral Oils / Water/Oil based fluids <i>(Minimum 40% Oil in Fluid)</i> <i>(Consult factory for other fluids.)</i>
Elements	
Media:	Dimicron - 2µm, 20µm / Water Removal - 2µm, 20µm
Number required:	OLF-5, 5/15, and 5/4 = 1
Dirt Holding Capacity - ΔP = 36 psi (2.5 bar)	200g ISO MTD <i>(N5DM...)</i> / 185g ISO MTD <i>(N5AM...)</i>
Water Retention - ΔP = 36 psi (2.5 bar):	Approximately 0.5 quarts (0.5 liters)
Beta Ratio:	β _x > 1000 <i>(absolute value)</i>
Maximum ΔP:	45 psi (3 bar)
Connections <i>(All Female)</i>	
OLF-5 with motor/pump:	Inlet & Outlet: 3/4 - 16UNF (SAE 8) (BSPP G1/2)
OLF-5/15 & 5/4:	Inlet & Outlet: 1 5/16-12UN (SAE 16) (BSPP G1)
OLF-5 without motor/pump:	Inlet: 9/16-18UNF (SAE 6) (BSPP G3/8) Outlet: 3/4-16UNF (SAE 8) (BSPP G1/2)
Weight	OLF-5-S = 15.5 lbs. (7.0 kg) OLF-5-E = 5.5 lbs. (2.5 kg) OLF-5/15 = 24.3 lbs. (11 kg) OLF-5/4 = 24.3 lbs. (11 kg)

Housing drain standard on all units

Black = SAE connections when using supplied adapters (standard)

Red = BSPP connections if supplied adapters are not used

Model Code

OLF-5 - S - 120 - K - N5DM002 - E / 12 / CD

Series

- OLF-5 = Series 5 (1.6 gpm)
- OLF-5/15 = Series 15 (4.9 gpm)
- OLF-5/4 = Series 15 (1.3 gpm)
- OLFCM-5/15 = With Fluid Condition Monitoring

Pump Type

- S = Vane Pump* (standard)
- E = Flow Control Valve (series 5 only)
- TV = Toploader with Motor (available for OLF-5/15 & OLFCM-5/15 only)

Power Consumption

- 120 = 120W for all OLF 5
- 200 = 200W for all 24VDC
- 370 = 370W for all Series 5/15 & 5/4
- Z = Without motor-pump unit (series 5 only)

Voltage

- K = 115V single phase
- M = 220V single phase
- N = 440V 3 phase
- T = 12VDC
- U = 24VDC
- Z = Without motor-pump unit

Element

- N5DM002 = 2 micron
- N5DM005 = 5 micron
- N5DM010 = 10 micron
- N5DM020 = 20 micron
- N5AM002 = 2 micron with water removal
- N5AM020 = 20 micron with water removal

Clogging Indicator

- E = Standard gauge (series 5 & 5/4 only)
- F = Static electrical switch VMF2F.0 (series 5 & 5/4 only)
- BM = Differential visual VM2BM.1 (series 5/15 & 5/4 only)
- C = Differential electrical VM2C.0 (series 5/15 & 5/4 only)
- D = Differential electrical/visual VM2D.0/L... (series 5/15 & 5/4 only)

Mechanical Connections

- 12 = SAE Connections (standard)

Supplementary Details

- L24, L48, L115, L230 = Lamp for D-type clogging indicator (LXX, XX = voltage)
- C = with ContaminationSensor CS 1310 (without display; OLFCM only)
- CD = with ContaminationSensor CS 1320 (with display; OLFCM only)
- AC = with ContaminationSensor CS 1310 and AquaSensor AS 1000 (without display; OLFCM only)
- ACD = with ContaminationSensor CS 1320 and AquaSensor AS 3000 (with display; OLFCM only)

Consult Factory for special options.

Not all combinations available.

*Choose "S" for model without motor-pump and without flow control valve.

For replacement element part numbers, please see Section E - REPLACEMENT ELEMENTS of this catalog.

Model Codes Containing RED are non-standard items – Minimum quantities and longer lead times may apply - Contact HYDAC for information and availability.

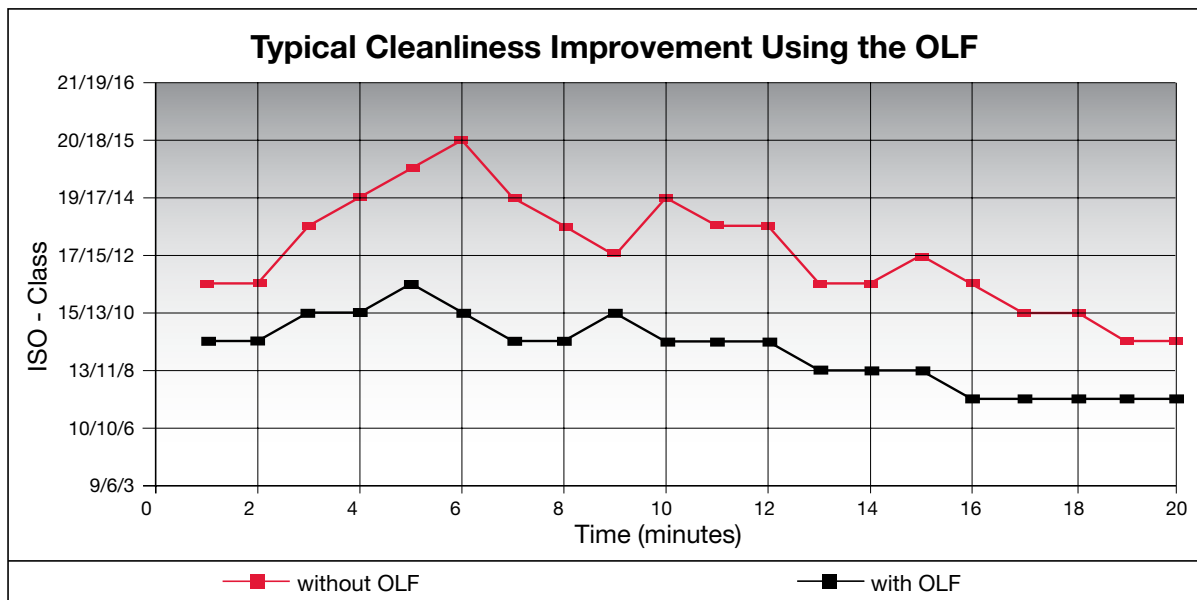

OFFLINE FILTRATION SYSTEMS

Dimensions

OLF-5-S-...

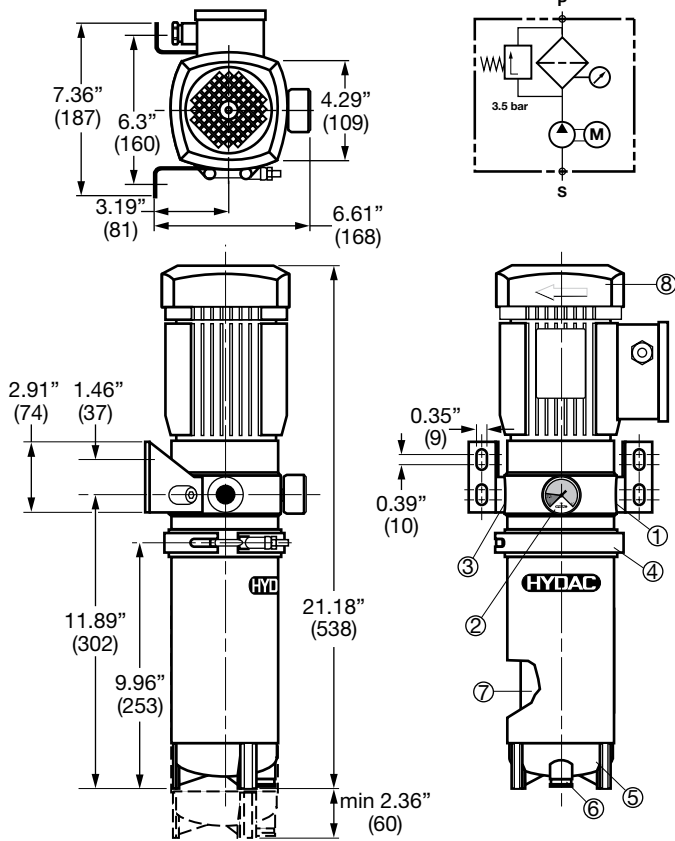

OLF-5-E-...

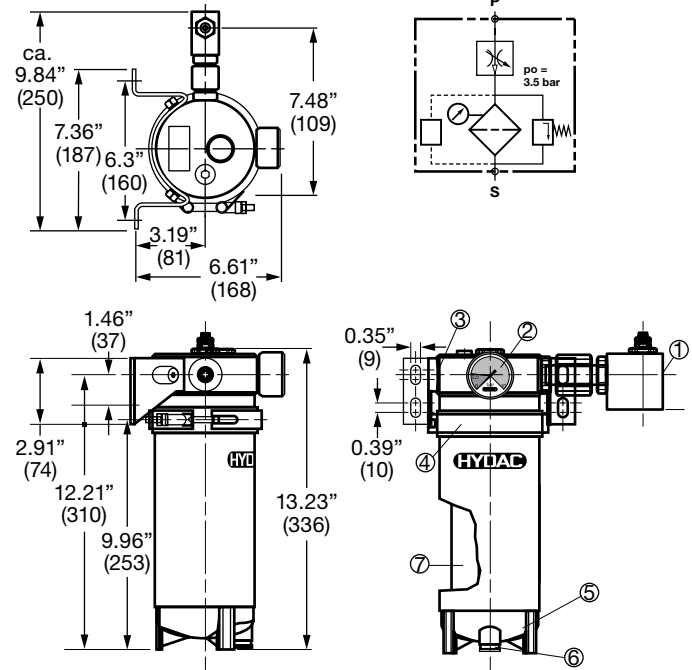

Key

- | | |
|------------------------|--------------------|
| 1 = Inlet | 5 = Filter Bowl |
| 2 = Clogging Indicator | 6 = Drain |
| 3 = Outlet | 7 = Filter Element |
| 4 = Clamp | 8 = Electric Motor |

OLF-5/4-S-... and OLF-5/15-S-...

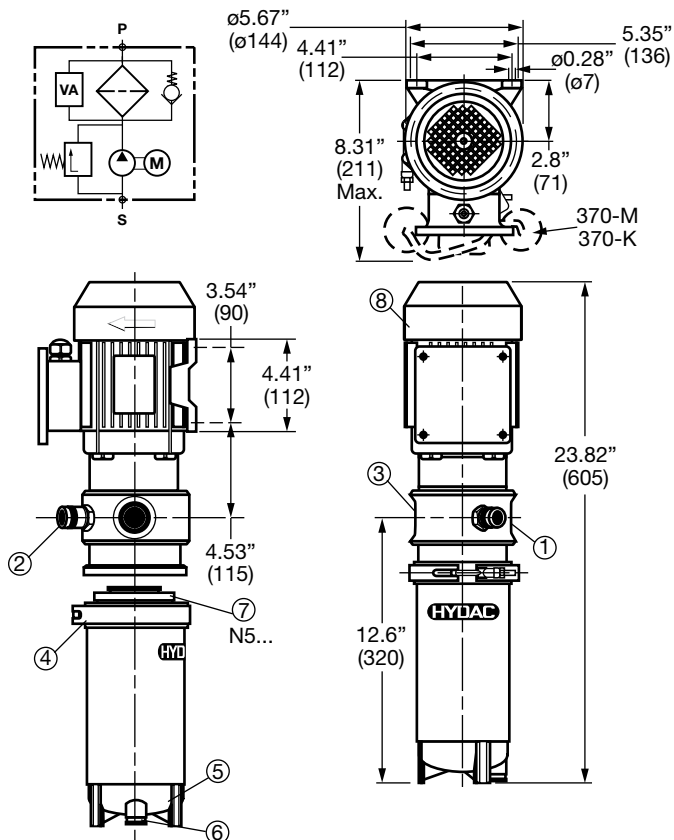

OLF-5/4-SP-...

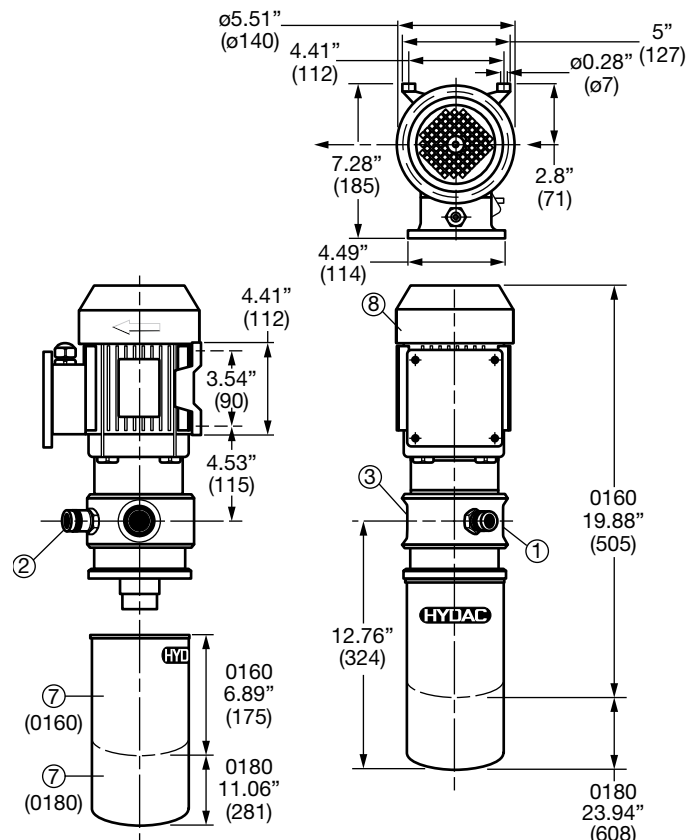

Dimensions are for general information only, all critical dimensions should be verified by requesting a certified print.

Differential Pressure

N5DM002

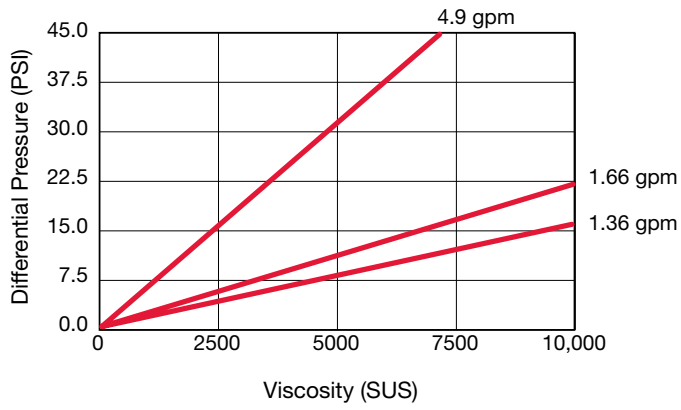

N5DM020

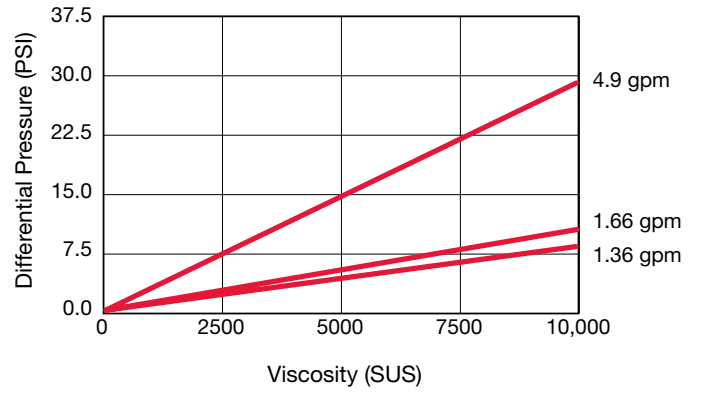

SRV Flow Control Valve Curve



Application

- Tank capacity to approx. 200 gallons
- Tank capacity to approx. 525 gallons

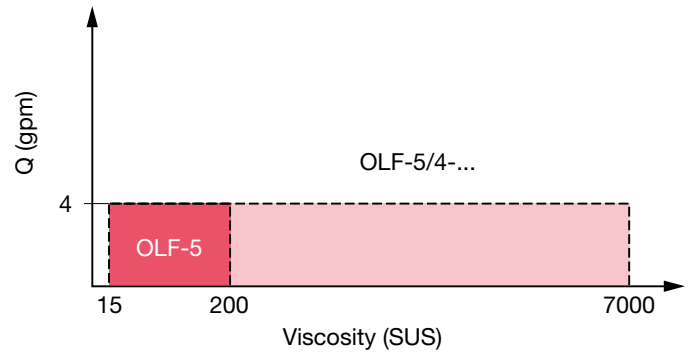

OFFLINE FILTRATION SYSTEMS

OLF Series



Applications

Typical applications include:

- Filling and flushing hydraulic units
- Filtration of fluids for hydraulic systems and test stands
- Filtration of cleaning fluids for parts washing machines
- Filtration of coolants

Dimicron® Element

The synthetic membrane (*2µm absolute*) provides a high filtration rating while the cellulose filter layer collects and holds the bulk of the dirt load. This combination results in excellent removal efficiency, even in a single pass, and extremely high dirt holding capacity.



Features and Benefits

The OLF series of filters is designed to efficiently and cost effectively filter hydraulic oils, lubricating oils, cleaning fluids and coolants which are highly contaminated. The filters can be supplied either as individual filters or as ready-to-install offline units complete with optional motor and pump units.

- Lower Operating Costs
- Extended Element Service Life
- Cleaner, more efficient systems

Dimicron® Technology

Dimicron® technology, which incorporates membrane filtration and multi-disc construction, sets the OLF apart from conventional filters by providing it with exceptional dirt holding capacity and separation efficiency. Each filter element is able to capture and hold more than 1 pound of dirt, meaning that the OLF60, which uses four elements, will hold nearly 5 pounds of dirt. Membrane filtration provides the OLF with a separation efficiency over 99.9% for particles 2 micron and larger (B2 > 1000) even in a single pass.

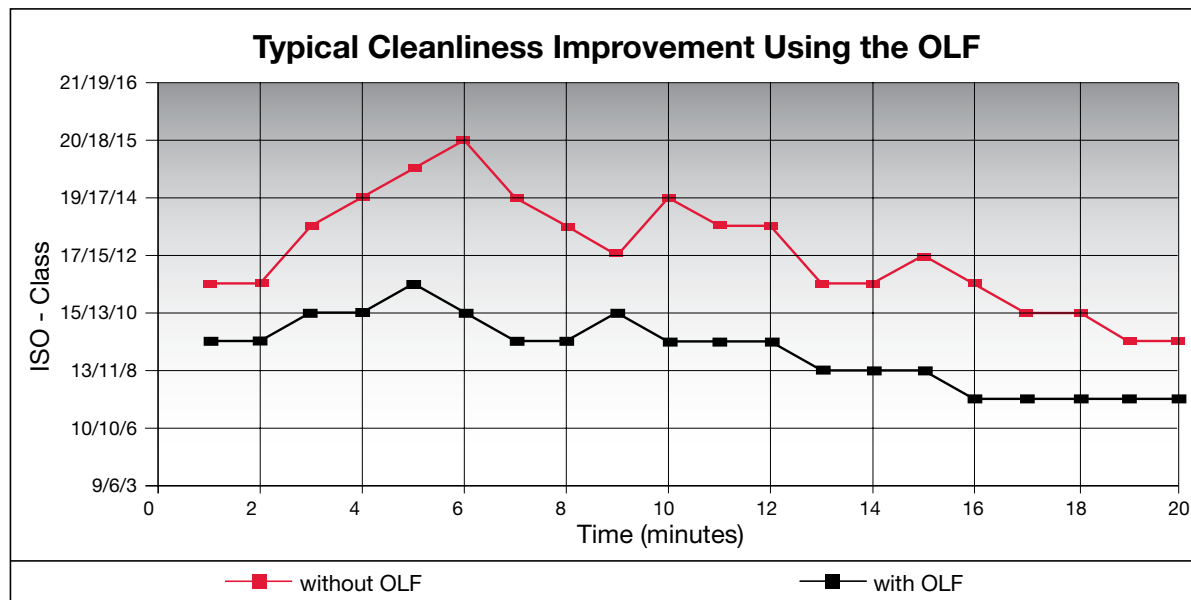
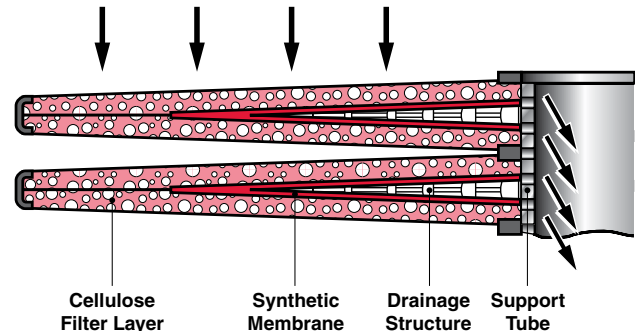

Model Code

OLF - 15 / 15 - G - L60 - N15DM002 - E / 12

Series

- OLF = Stationary offline filter with integrated pressure gauge
- OLFCM = Stationary offline filter with integrated contamination monitoring sensors

Size

15 = 1 element, 30 = 2 elements, 45 = 3 elements, 60 = 4 elements

Pump Flow Rate *(must be less than or equal to size)*

- 15 = 5 gpm
 - 30 = 10 gpm
 - 45 = 15 gpm
 - 60 = 20 gpm
 - Z = without pump
- This code entry (15,30, 45, 60) must be less than or equal to the size entry (15,30, 45, 60)*

Pump Type

- S = vane pump
- G = gear pump
- Z = Without motor-pump

Motor Voltage

- L60 = 115V, Single Phase
- O60 = 460V, Three Phase
- Z = Without motor-pump

Filter Element

- N15DM002 = Dimicron® 2 µm Absolute
- N15DM010 = Dimicron® 10µm Absolute
- N15DM020 = Dimicron® 20 µm Absolute
- N15DM030 = Dimicron® 30 µm Absolute
- Z = No filter element supplied

Clogging Indicator

- E = Standard gauge
- BM = Differential visual VM2BM.1
- C = Differential electrical VM2C.0
- D = Differential visual/electrical

Options

- 12 = SAE adapters *(BSPP connections are standard)*
 - V = Viton® Seals *(NBR seals are standard)*
 - MP = Integrated TestPoint for connection to FCU via Minimesse Line
 - C = ContaminationSensor CS 1310 *(without Display)*
 - CD = ContaminationSensor CS 1320 *(with Display)*
 - CS = ContaminationSensor CS 1310 *(without Display) with SMU1260*
 - AC = Contamination Sensor CS 1310 and AS 1000 *(without Display)*
 - ACD = ContaminationSensor CS 1320 and AS 3000 *(with Display)*
 - ACS = ContaminationSensor CS 1310 and AS 1000 *(without Display) with SMU1270*
- (OLFCM option only)*

For replacement element part numbers, please see Section E - REPLACEMENT ELEMENTS of this catalog.

Model Codes Containing RED are non-standard items – Minimum quantities and longer lead times may apply - Contact HYDAC for information and availability.

Dimensions

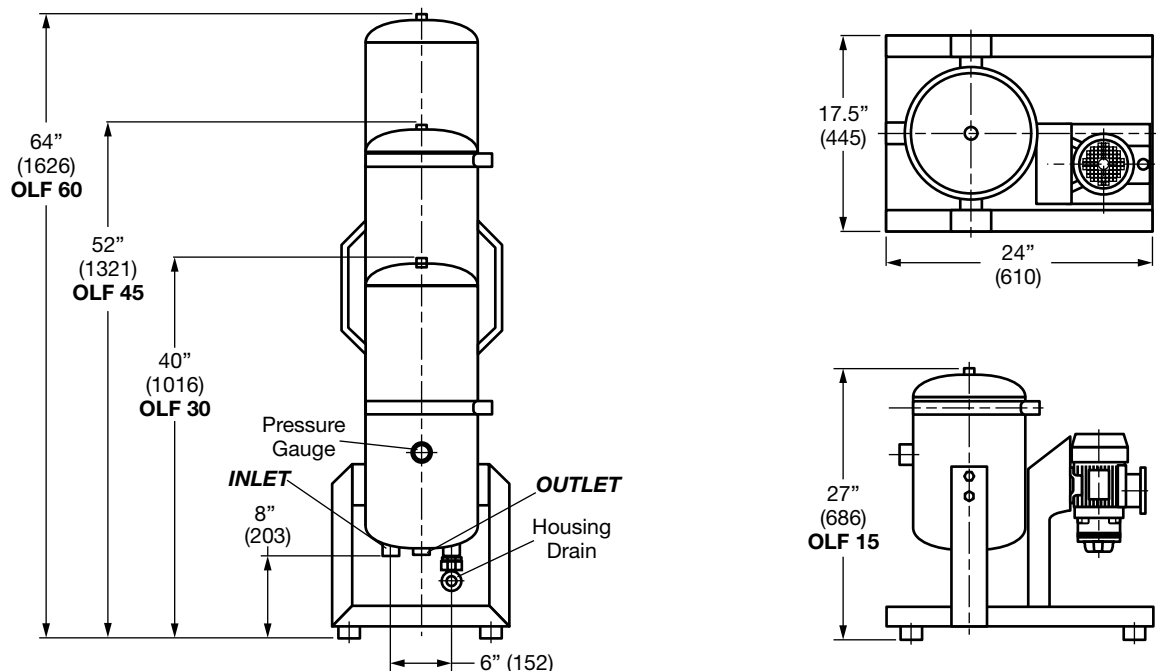

Dimensions are for general information only, all critical dimensions should be verified by requesting a certified print.

OFFLINE FILTRATION SYSTEMS

Technical Specifications

Model	OLF-15	OLF-30	OLF-45	OLF-60
Connections	Female			
Housing Inlet & Outlet	1 5/16 - 12UN (SAE 16); G 1" BSPP			
Pump Inlet: Vane	1 1/16 -12UN (SAE 12); G 3/4" BSPP	1 5/8 -12UN (SAE 20); G 1 1/4" BSPP		
Pump Inlet: Gear	1 1/16 -12UN (SAE 12); G 3/4" BSPP	1 5/16 -12UN (SAE 16); G 1" BSPP	1 7/8 -12UN (SAE 24); G 1 1/2" BSPP	
Pump Inlet: Centrifugal	1 5/16-12UN (SAE 16); G 1" BSPP		1 5/8 -12UN (SAE 20); G 1 1/4" BSPP	
Filter Element	N15DMxxx(1x)	N15DMxxx(2x)	N15DMxxx(3x)	N15DMxxx(4x)
Contamination Retention Capacity	1.1lbs (500g)	2.2lbs (1000g)	3.3lbs (1500g)	4.4lbs (2000g)
Filter Efficiency	βx > 1000			
Permissible Δp Across the Element	72.5 psi (5 bar)			
Element Weight	6.6lbs (3 kg)	13.2lbs (6 kg)	19.8lbs (9 kg)	26.4lbs (12 kg)
Material of Filter Housing	Stainless Steel			
Capacity of Pressure Vessel	5.25 gal. (20 l)	10.50 gal. (39.7 l)	15.75 gal. (59.6 l)	20.5 gal. (28.1 l)
Max. Operating Pressure - Filter Housing	85 psi (5.86)			
Material of Seals - Housing	NBR (standard)			
Housing Weight	25lbs (11.3 kg)	33lbs (15 kg)	53lbs (24 kg)	62lbs (28.1 kg)
Fluid Temperature	15 to 175°F (-9.4 to 79.4°C)			
Motor-Pump Units	5 gpm (18.9 lpm)	10 gpm (37.8 lpm)	15 gpm (56.8 lpm)	20 gpm (75.5 lpm)
Pump Operating Pressure	65 psi (4.5 bar)			
Vane Pump Viscosity Range	75-2500 SUS (14 to 540 cSt)			
Vane Pump Motor Capacity	370 W	570 W	1500 W	1500W
Gear Pump Viscosity Range	7-5000 SUS (14 to 1078 cSt)			
Gear Pump Motor Capacity	370 W	570 W	1500 W	1500W
Material of Seals - Pumps	NBR (standard)			
Dry Weight of OLF System	50 lbs. (22.7 kg)	77 lbs. (34.9 kg)	116 lbs. (57.6 kg)	132 lbs. (60 kg)

Housing drain standard on all units

BLACK = SAE connections when using adapters which are supplied standard

RED = BSPP connections if supplied adapters are not used

Differential Pressure at 3.96 gpm (15 L/min)

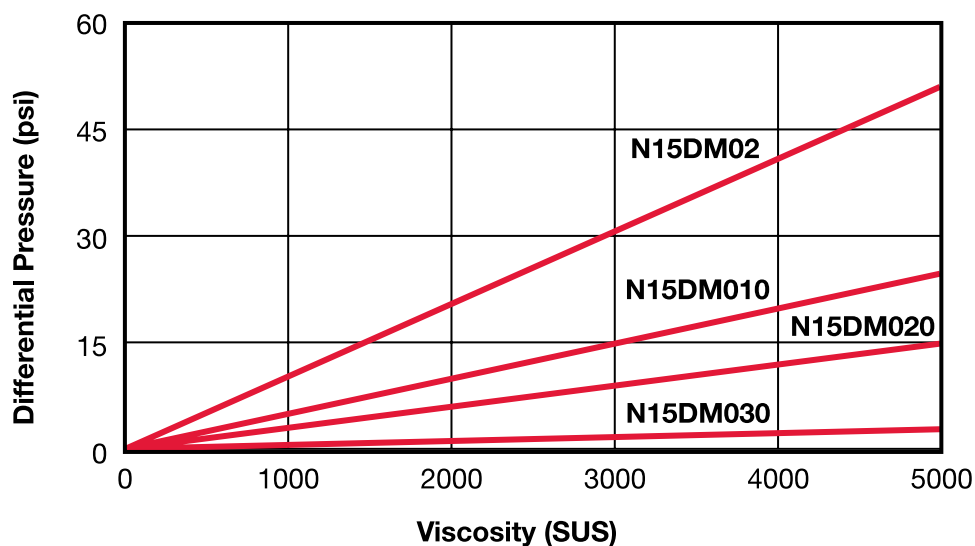

Sizing Offline Filtration

The following calculations will help to approximate the attainable system cleanliness level when applying offline filtration.

Step 1: Select the approximate contamination ingress rate from the chart below. HYDAC quantitative investigations have yielded the following approximate figures.

Type of System	Contamination Ingression (µg/gal) Surroundings		
	Clean	Normal	Polluted
Closed circuit	1	3	5
Injection molding machine	3	6	9
Standard hydraulic system	6	9	12
Lubrication system	8	11	14
Mobile equipment	10	13	16
Heavy industrial press	14	18	22
Flushing test equipment	42	60	78

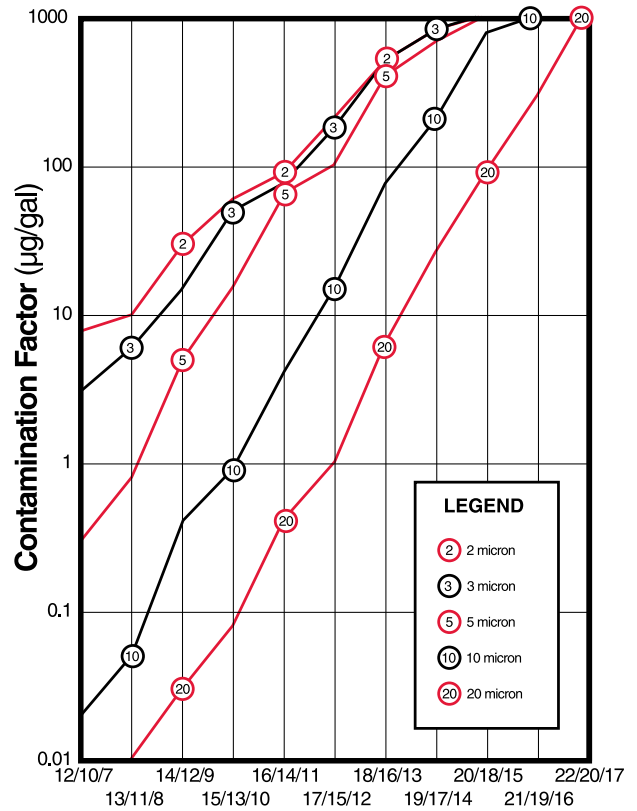

Step 2: Make the correction required for offline filtration. The contamination input selected above must be multiplied by the factor:

Main System Flow Rate / Desired Offline Flow Rate

Note: Main system flow rate must be corrected for cycle time. For example, if the flow rate is 500 gpm, but only runs for 20% of the system cycle, the main system flow rate would be 100 gpm. (500 gpm X 20%)

This yields the expression:

$$\text{Contamination Factor} = \text{Contamination Input } (\mu\text{g/gal}) \times$$

$$\frac{\text{Main System Flow Rate (gpm)}}{\text{Desired Offline Flow Rate (gpm)}}$$

Calculate the contamination factor using this expression.

Step 3: Determine the attainable cleanliness level. Locate the calculated contamination factor on the y-axis of the attached graph. Go to the right to find the intersection point on the curve corresponding to the desired absolute filter micron rating. Read the resulting attainable cleanliness level on the x-axis. (In case of dynamic flow through the offline filter, the attainable cleanliness level will be 2 to 3 times worse than indicated by the graph.)

Offline Filtration Sizing Example

Type of System: Heavy industrial press

Surroundings: Normal

Main System Flow Rate: 150 gpm

Desired Offline Flow Rate: 20 gpm = 135 (OLF 60)

Step 1: Using this criterion select the approximate contamination ingress rate from the chart above.

This yields a contamination input of **18 µg/gal** based on a **heavy industrial press** with **normal** surroundings.

Step 2: Make the correction required for offline filtration.

$$\text{Contamination Factor} = 18 \mu\text{g/gal} \times 150 \text{ gpm} / 20 \text{ gpm} = 135$$

Step 3: Determine the approximate attainable cleanliness level for each micron rating using the attached graph. If the attainable cleanliness level is not acceptable, the desired offline flow rate should be increased. The approximate attainable levels for this example are as follows.

2µm - ISO 17/15/12

20µm - Between ISO 20/18/15 and ISO 21/19/16

OFFLINE FILTRATION SYSTEMS

OLFP 1 / 3 / 6 Series

Offline Filter Pressure

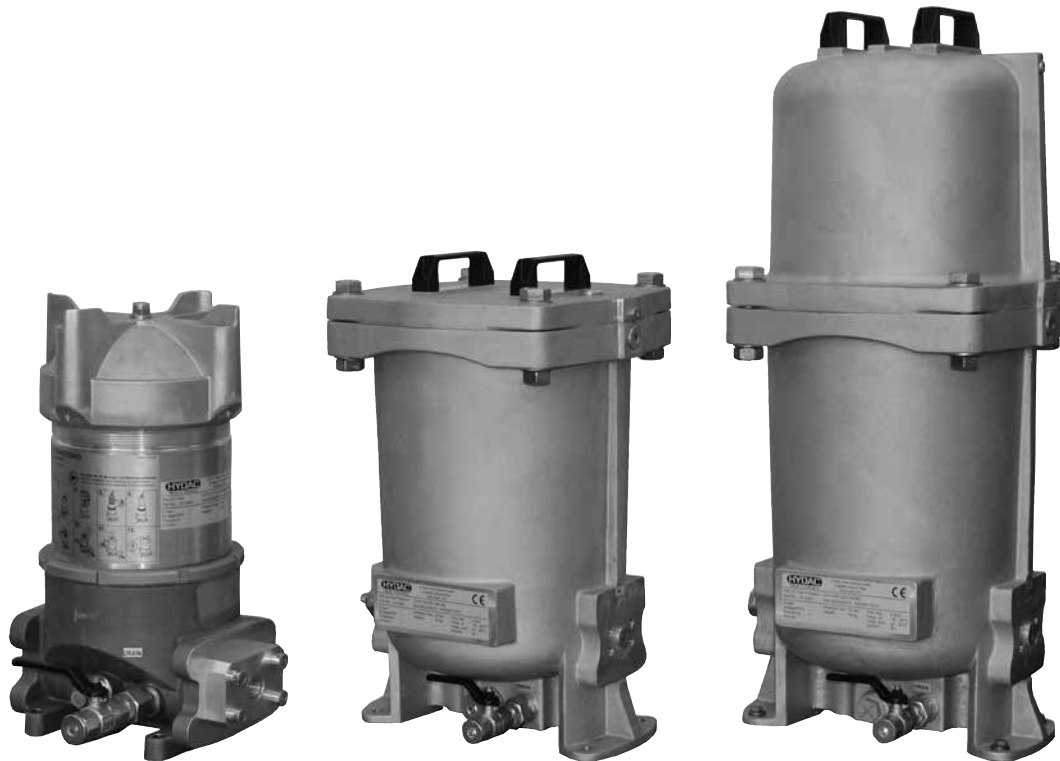

Description

The OffLine Filter Pressure (OLFP) system is a stationary offline filter and is used to remove oil aging products, water and solid particles from hydraulic and lubrication fluids.

Thanks to its compact construction, the OLFP is also ideally suited for use in even the smallest of installation spaces. The housings are pressure resistant up to 290 psi (20 bar). Since the housing material is aluminium, the filters are also suitable for low-temperature applications.

The flow can be taken directly from the main flow through an orifice and the orifice determines the flow rate. The offline filters can also be equipped with a motor-pump unit and an inductive particle counter, as an option.

The Trimicon series of filter elements NxTMxxx have been specially developed for the combined removal of fine particles, water and oil aging products. The most modern filter materials with reliable separation characteristics and high contamination retention capacity are used for this purpose.

Features

- Removal of oil aging products, solid particles and water
- Improvement in component lifetime
- Greater machine availability
- Less space required due to compact construction
- Very easy maintenance
- High contamination retention capacity of the elements

Applications

- Wind power plants
- Industrial transmission systems

Technical Specifications

Model	OLFP 1	OLFP 3	OLFP 6
Operating Pressure	Max. 363 psi (25 bar)	Max. 290 psi (20 bar)	
Fluid Temp. Range	-22° F to 176° F (-30° C to 80° C)		
Max. Operating Viscosity	4635 SUS (1000 cSt)		
Ambient Temp. Range	-22° F to 176° F (-30° C to 80° C)		
Survival Temp.	-40° F (-40° C)		
Storage Temperature	-40° F to 176° F (-40° C to 80° C)		
Head Material	Aluminum		
Bowl Material	Aluminum		
Seals	FPM/NBR		
Filter Housing Content	~2.4 gal. (~9 liters)	~7.1 gal. (~27 liters)	~11 gal. (~43 liters)
Hydraulic Port (IN/OUT)	See table "Hydraulic Connections"		
Filter Element	1 x N1TMXXX	1 x N3TMXXX	2 x N3TMXXX
Weight	~46.3 lbs (~21 kg)	~82 lbs (~37 kg)	~90 lbs (~41 kg)

Model Code

OLFP - 1 / 2 - G M - M - TM - N E

Series

- OLFP = Offline Filter - Pressure
- OLFPCM = Offline Filter - Pressure with Condition Monitoring (CM)

Size

- 1 = Filter size 1 (1 x filter element N1TM003 *)
- 3 = Filter size 3 (1 x filter element N3TM003 *)
- 6 = Filter size 6 (2 x filter element N3TM003 *)

Nominal Flow Rate / type of orifice

- 2 = 0.53 gpm (2 l/min) - orifice A
- 3 = 0.79 gpm (3 l/min) - orifice B
- 6 = 1.59 gpm (6 l/min) - orifice C
- Z = variable (without orifice, without pump)

Pump Unit

- O = with orifice
- G = gear pump
- Z = without

Electric Motor

- M = 230 V / 50 HZ / 1 Ph / 0.37 kW
- N = 400 V / 50 HZ / 3 Ph / 0.37 kW
- AB = 690 V / 50 HZ / 1 Ph / 0.37 kW
- X = Other voltages
- N60, M60 = Operation at 60 HZ
- Z = Without electric motor

Measurement Technology

- M = MCS 14xx Metallic Contamination Sensor
- A = AS 1000 Aqua Sensor
- Z = without (for basic type OLFP)

Element Type

- TM = Trimicron

Sealing Material

- N = NBR
- F = FPM

Clogging Indicator

- E = Standard, back-pressure indicator
- B = Differential pressure indicator, visual (VM2BM.x)
- C = Differential pressure indicator, electrical (VM2C.x)
- D3 = Differential pressure indicator, visual/electrical (VM2D.x)
- D38 = Differential pressure indicator, visual/electrical (VL x GW.0 /-V-113)
- Z = without

* filter element not supplied. These must be ordered separately.

Items supplied (Preferred models, designed for 87 psi (6 bar) inlet pressure)

- OffLine Filter OLFP 1 - OffLine Filter OLFP-1/2-OZ-Z-TM-NZ Part no. 3738168
- OffLine Filter OLFP 3 - OffLine Filter OLFP-3/3-OZ-Z-TM-NZ Part no. 3712592
- OffLine Filter OLFP 6 - OffLine Filter OLFP-6/6-OZ-Z-TM-NZ Part no. 3712591

Hydraulic Connections

Type	IN				OUT		
	SAE 2"	SAE 3/4"	G 3/4"	G 1/2"	SAE 2"	G 3/4"	G 1/2"
OLFP-1/Z-ZZ-Z-TM-NZ	•	-	-	-	•	-	-
OLFP-1/2-OZ-Z-TM-NZ	-	-	•	-	•	-	-
OLFP-3/Z-ZZ-Z-TM-NZ	-	•	-	•	-	-	•
OLFP-3/3-OZ-Z-TM-NZ	-	-	•	-	-	•	-
OLFP-6/3-GN-Z-TM-NZ	-	•	-	-	-	-	•
OLFPCM-6/3-GN-MA-TM-NZ	-	•	-	-	-	-	•

Replacement Elements

Model Code	Micron Rating	Part No.
N1TM003	3	3284980
N3TM003	3	3566060

Flow Rate Through Orifice (up to 200 mm²/s)

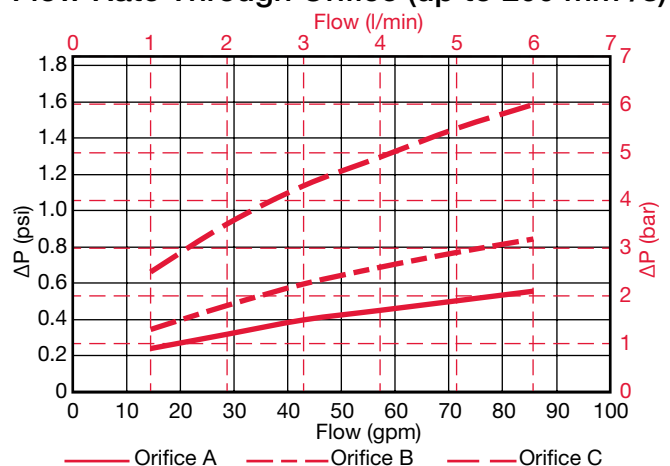

Type	Nominal Flow Rate	Orifice
OLFP x/2	0.53 gpm (2 l/min)	A
OLFP x/3	0.79 gpm (3 l/min)	B
OLFP x/6	1.59 gpm (6 l/min)	C
OLFP x/z	variable	-

Values are valid for clean elements only.

OFFLINE FILTRATION SYSTEMS

Dimensions OLFP 1

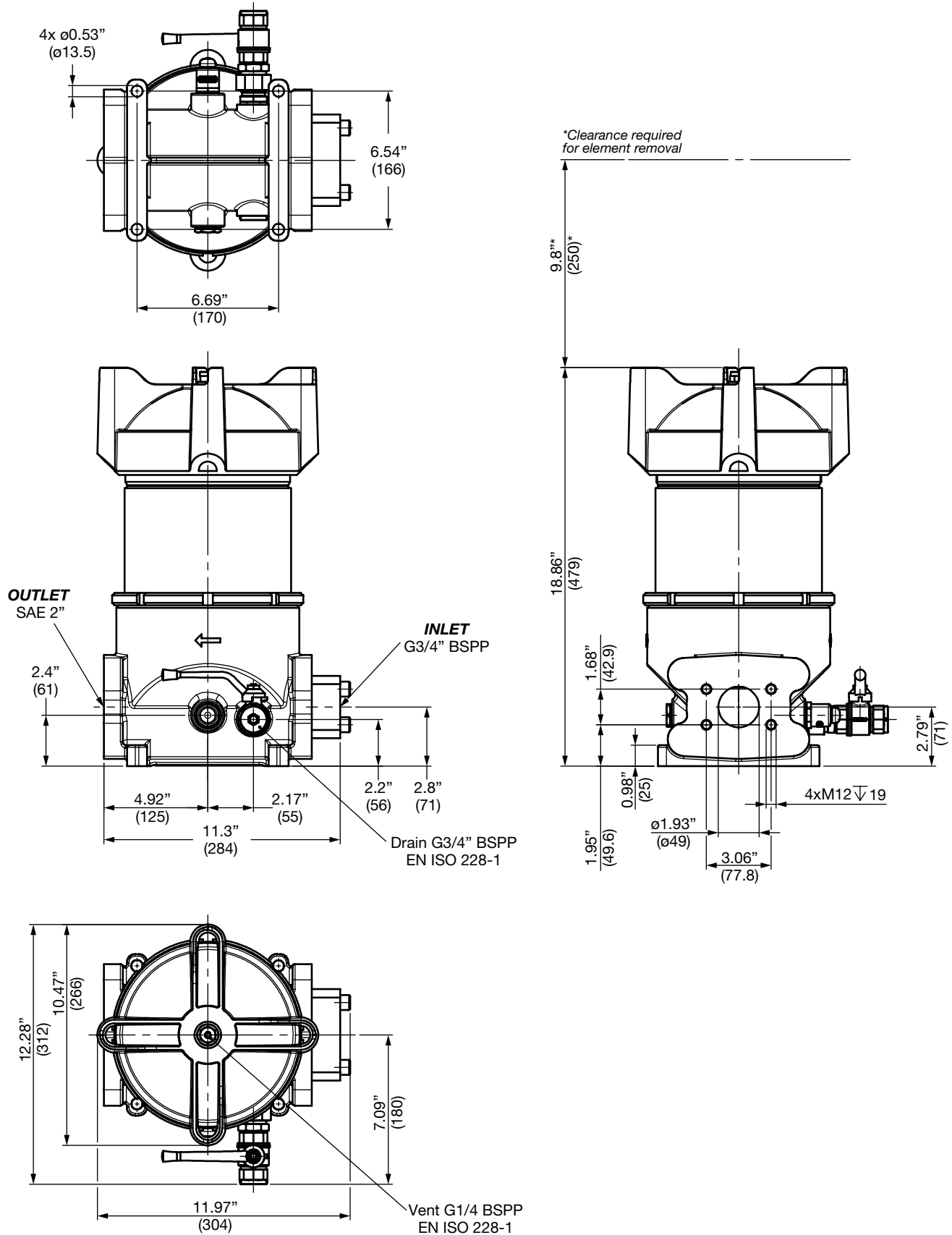

Dimensions are for general information only, all critical dimensions should be verified by requesting a certified print.

Dimensions OLFP 3 / 6

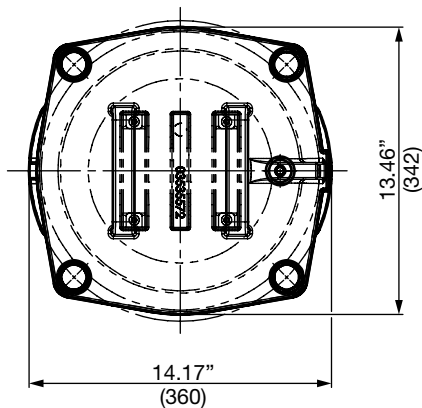
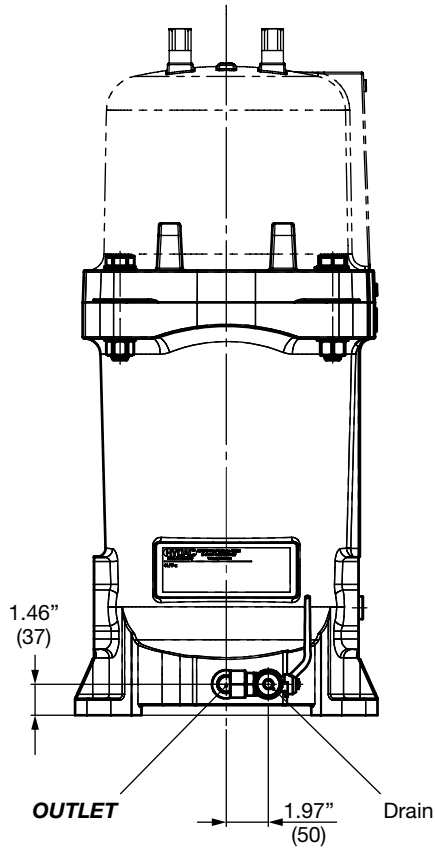
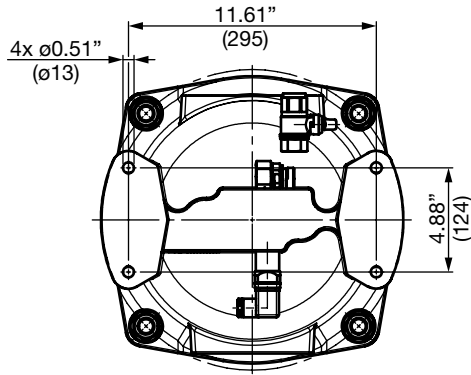

*Clearance required for element removal

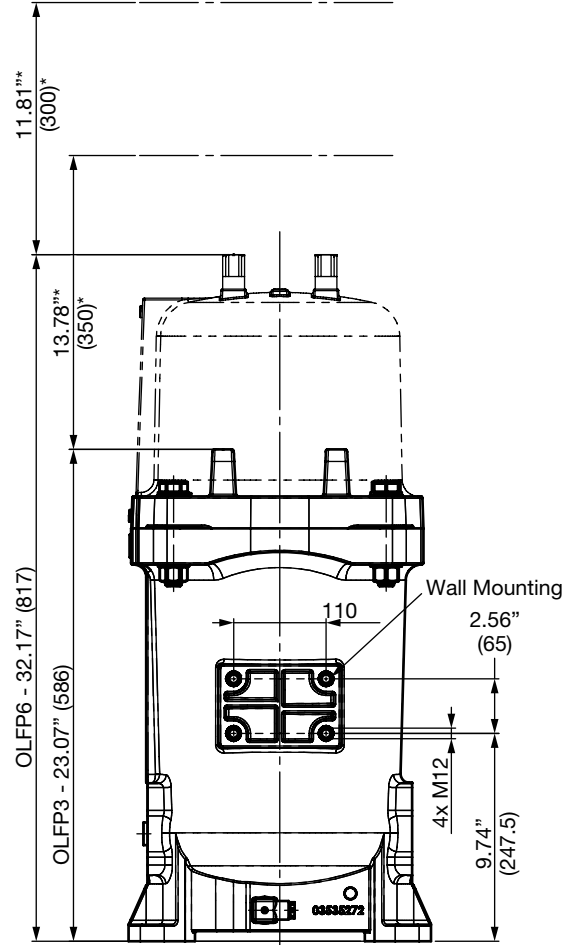

Hydraulic Schematic

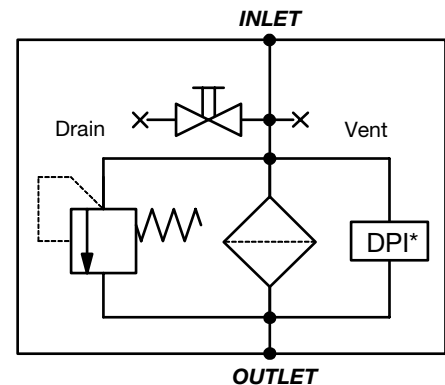

*Option: Differential pressure indicator

Dimensions are for general information only, all critical dimensions should be verified by requesting a certified print.

OFFLINE FILTRATION SYSTEMS

NxTM TriMicron Element Series



Description

The filter elements in the TriMicron series have been specially developed for the combined filtration of

- fine solid particle contamination,
- water and
- oil-ageing products from hydraulic and lubrication oils in the bypass flow.

They are a combination of pleated and SpunSpray depth filter elements. The filter layers are produced using melt-blown technology (synthetic fibers).

Features

- Excellent filtration performance ($\beta_{s(c)} > 1000$)
- Low initial differential pressure
- High contamination retention capacity
- Fine particle contamination, water and oil aging products removed by depth filter material
- Broad range of fluid compatibility
- Simple element change

Applications

- Offline filtration in lubrication systems (e.g. in wind turbines)
- Offline filtration in hydraulic systems
- Transmission and hydraulic test rigs

Technical Specifications

Model	N1	N3
Contamination Retention Capacity ISOMTD at $\Delta P = 36.3$ psi (2.5 bar)	~ 410 g	~ 2500 g
Water Retention Capacity	~ 680 ml	~ 2.1 l
Beta value $\beta_{s(c)}$ @ 29 psi (2 bar)	> 1,000	
Filtration Rating	3 μ m	
Differential Pressure at Starting Point	1.45 psid (< 0.1 bar)	
Permitted Fluid Temperature Range	14 to 176 °F (-10 to 80 °C)	
Storage Temperature Range	41 to 104 °F (5 to 40 °C)	

Model Code

N 1 TM 003 /- N

Nominal Flow Rate

- 1 = Nominal flow rate 0.26 gpm (1 lpm)
- 3 = Nominal flow rate 0.79 gpm (3 lpm)

Element Type

- TM = TriMicron

Filtration Rating (microns)

- 003 = 3

Sealing Material

- N = NBR
- F = FPM

Element Differential Pressure

N1TM

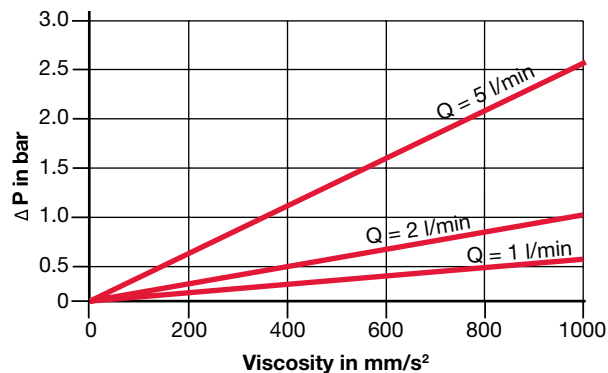

N3TM

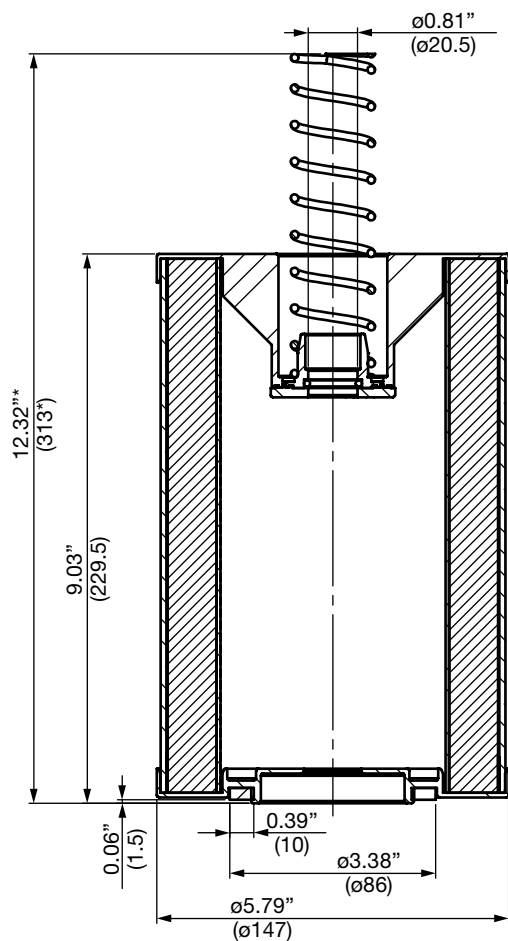
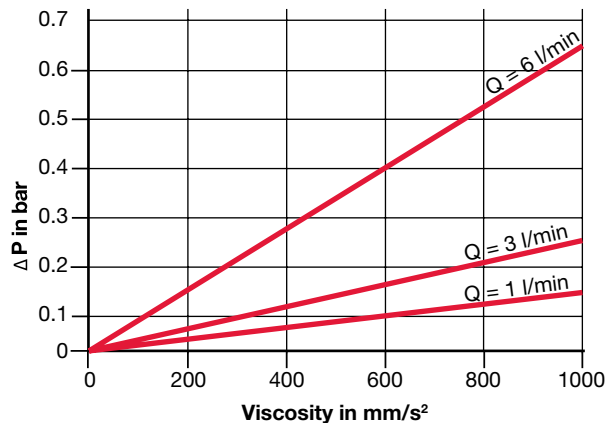

* spring unloaded
** spring loaded

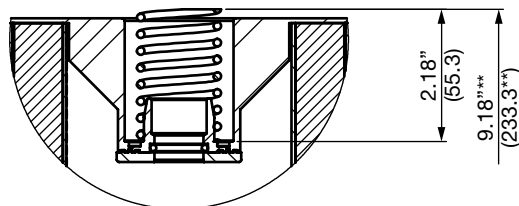

Dimensions are for general information only, all critical dimensions should be verified by requesting a certified print.

OFFLINE FILTRATION SYSTEMS

MAFH-A Series

Dehydration Station



Cart

Description

Water contamination in hydraulic systems can severely reduce the life of hydraulic systems and fluids. The MAFH is designed to eliminate 100% of free and up to 90% of dissolved water from small reservoirs, barrels, and gear boxes. Using a patented transfer process, the MAFH efficiently removes water and particulate contamination quickly in all environments. A proprietary design reduces aeration of free and entrained gases of returned fluid. The unit was designed to be extremely portable due to small footprint and cart to access tight areas.

Principle of Operation

The MAFH uses a new mass transfer dewatering technology. Ambient air is conditioned to increase its water holding capability before injecting to the reaction chamber. Fluid is equally distributed and cascaded down through reticulated media and the conditioned air stream. Water is transformed to water vapor and is expelled from the unit as a moist air stream. The relative humidity of the incoming fluid is continually monitored by an integral AS 1000 AquaSensor and displayed real-time on the control panel.

Applications

- Steel and rolling mills
- Pulp and paper plants
- Power generation plants
- Tool machines / Plastic machines
- Hydraulic operated presses
- Oil conditioning

Features

- High Dewatering Rates and particulate removal in one system
- Simple Controls; RUN/DRAIN modes
- Reduce fluid recycling cost
- No expensive vacuum pump to service and replace
- Patented mass transfer technology uses ambient air to optimize and control dewatering rates
- Remove free and dissolved water
- Highly effective in low and high humidity elements

Technical Specifications

Type	Cart Ver. (standard)
Dimensions	44"h x 20.3"w x 36.7"d
Weight	295 lbs (134 kg)
Inlet Connections	1" SAE
Outlet Connections	
Flow Rate	90 gallons/hour (341 lph)
Inlet Pressure	Atmospheric
Outlet Pressure	to 40 psi (2.75 bar)
Fluid Service Temp.	50° F to 175°F (10°C to 79°C)
Power Supply	110 VAC, 60 Hz, 12 AMP Explosion proof version (Option X): 460 VAC, 60Hz, 3Ph
Attainable Water Content	< 50 ppm
Relative Humidity Display	Standard, 0-99% Range
Materials of Construction	Vessel: Stainless steel Seals: FPM
Fluid Viscosity	1000 SUS Explosion proof ver. (Option X): 500 SUS max
Operating Fluids	Recommended for use with Hydraulic Fluids and Petroleum Based Fluids; (Consult factory for use with other fluid types)
Max. Recommended Hose L/Dia. 15 ft. max. hose length at 1000 SUS 1 1/4" (inlet), 1/2" (outlet)	At 70 SUS - 10 ft/0.75 (inlet) 15ft/0.5 (outlet) At 1000 SUS - 8ft/1.0 (inlet) 10ft/0.75 (outlet)
Max. Suction Pressure	-5.8 psi (-0.4 bar) (11.97 in Hg)

Model Code

MAFH - A - C - V - S - A - B - 01 - X

Series	MAFH = Dehydration station
Flow Rate	A = 1.5 gpm average
Type	C = Cart (standard)
Seals	V = Fluoroelastomer (FPM)
Mobility	S = Stationary M = Caster base
Voltage	A = 110V/60 Hz/1 Phase B = 220V/60 Hz /1 Phase
Air Source	B = Integral blower C = Compressed air (customer must supply clean, dry air)
Element Size	01, 03, 05, 10, 25
Options	X = Class 1, Div 2 explosion-proof, Supplied Voltage: 460V / 60Hz / 3Ph (contact factory if this option is required in for your application)

For replacement element part numbers, please see Section E - REPLACEMENT ELEMENTS of this catalog.

Model Codes Containing RED are non-standard items – Minimum quantities and longer lead times may apply - Contact HYDAC for information and availability.

Dimensions Cart

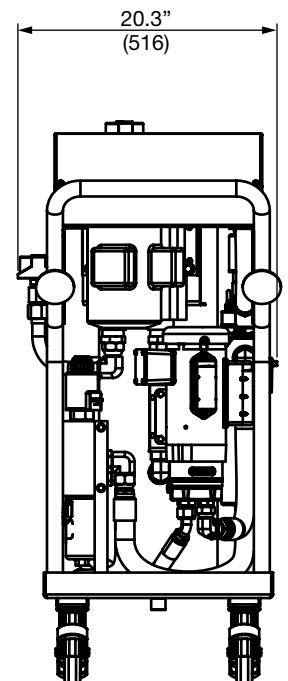
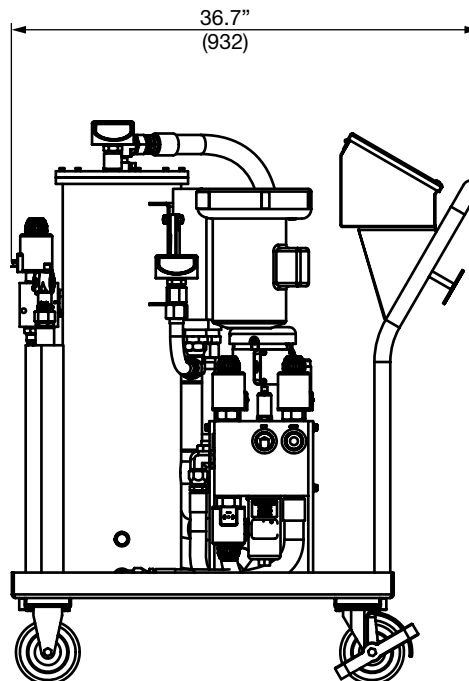
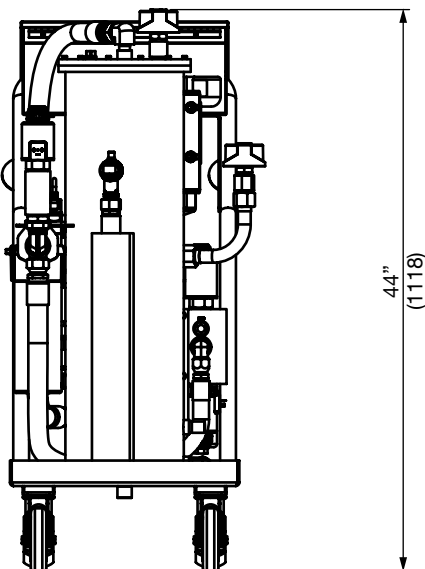
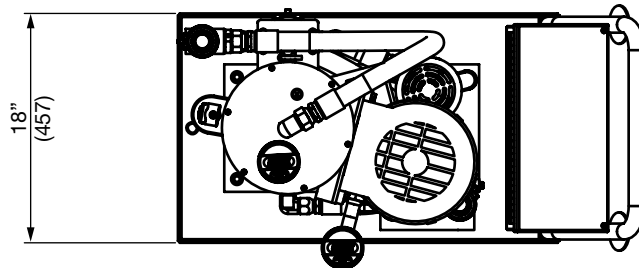

Dimensions are for general information only, all critical dimensions should be verified by requesting a certified print.

OFFLINE FILTRATION SYSTEMS

MAFH-E Series

Dehydration Station



Description

Water contamination in hydraulic systems can severely reduce the life of hydraulic systems and fluids. The MAFH-E is designed to eliminate 100% of free and up to 90% of dissolved water from reservoirs, barrels, and gear boxes. Using a patented transfer process, the MAFH-E efficiently removes water and particulate contamination quickly in all environments. A proprietary design reduces aeration of free and entrained gases of returned fluid. The unit was designed to be extremely portable using either the integrated lifting lugs located on each corner of the cart or the optional wheeled cart.

Principle of Operation

The MAFH-E uses a new mass transfer dewatering technology. Ambient air is conditioned to increase its water holding capability before injecting to the reaction chamber. Fluid is equally distributed and cascaded down through reticulated media and the conditioned air stream. Water is transformed to water vapor and is expelled from the unit as a moist air stream. The relative humidity of the incoming fluid is continually monitored by an integral AS 1000 AquaSensor and displayed real-time on the control panel.

Applications

- Steel and rolling mills
- Pulp and paper plants
- Power generation plants
- Tool machines / Plastic machines
- Hydraulic operated presses
- Oil conditioning

Features

- High Dewatering Rates and particulate removal in one system
- Simple Controls; RUN/DRAIN modes
- Reduce fluid recycling cost
- No expensive vacuum pump to service and replace
- Patented mass transfer technology uses ambient air to optimize and control dewatering rates
- Remove free and dissolved water
- Highly effective in low and high humidity

Technical Specifications

Dimensions	32" W x 59" L x 70.25" H
Dry Mass	Without Heater: 1050lbs (476 kg); With Heater: 1230lbs (558 kg)
Inlet Connections	1-1/2" MJIC
Outlet Connections	1-1/2" MJIC
Oil Viscosity	Min 75 SUS; Max 2500 SUS (14 to 539 cSt)
Flow Rate	up to 22 gpm (1320 gallons/hour)
Inlet Pressure	Atmospheric
Outlet Pressure	To 100psi (6.9 bar)
Fluid Service Temperature	50°F to 160°F (10°C to 71°C)
Power Supply	460V/3/60Hz, 13 amps 460V/3/60Hz, 28 amps w/Heater 575V/3/60Hz, 10.5 amps 575V/3/60Hz, 23 amps w/Heater
Attainable Water Content	<50ppm
Relative Humidity Display	Standard, 0-99% Range
Construction	Base Frame: Carbon Steel Vessel: Stainless Steel Seals: Viton
Protection Class	NEMA-2

Model Code

MAFH-E - - V - M - A - B - G05 - H

Series _____

MAFH-E = Dehydration Station

Flow Rate _____

(omit) = 15gpm
 22 = 22gpm
 VF = 3-15gpm Variable Flow

Seals _____

V = Fluoroelastomer (FPM)

Mobility _____

S = Stationary
 M = Mobile

Voltage _____

A = 460V/3/60 Hz
 B = 575V/3/60Hz

Air Source _____

B = Integral Blower

Element Size _____

G01, G03, G05, G10, G25

Optional Heater _____

H = 12500W Heater

For replacement element part numbers, please see Section E - REPLACEMENT ELEMENTS of this catalog.

Dimensions

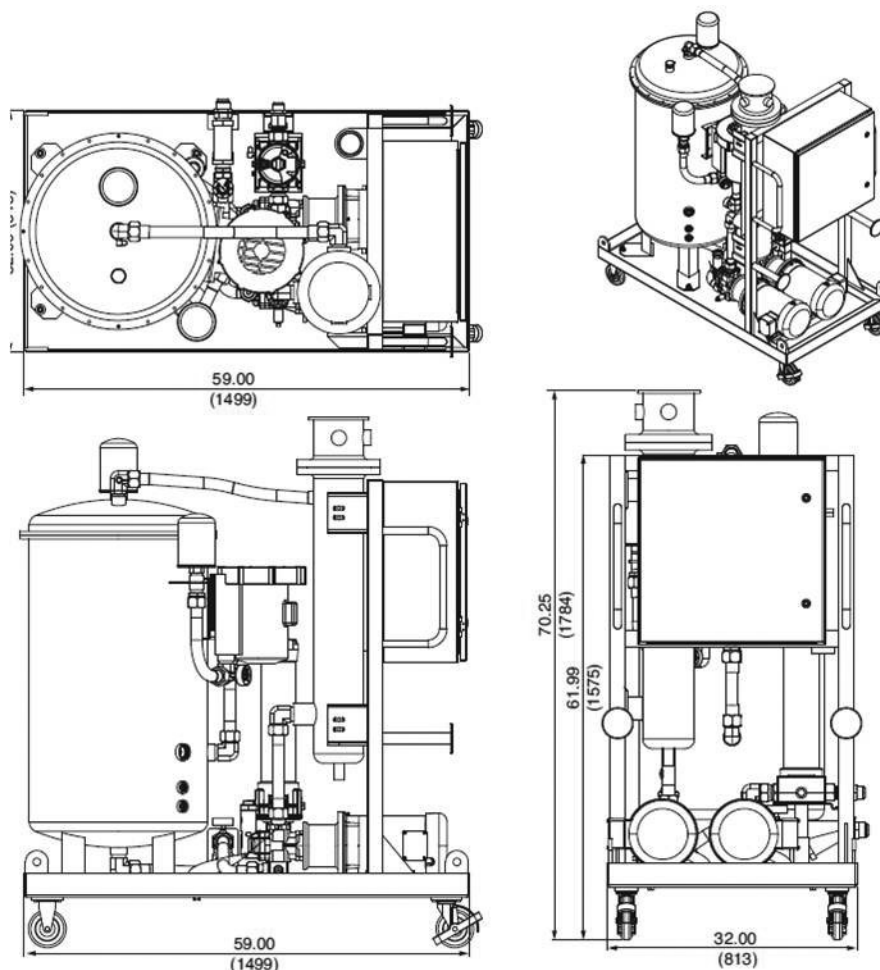

Dimensions are for general information only, all critical dimensions should be verified by requesting a certified print.

FAM5 Series

Fluid Aqua Mobile

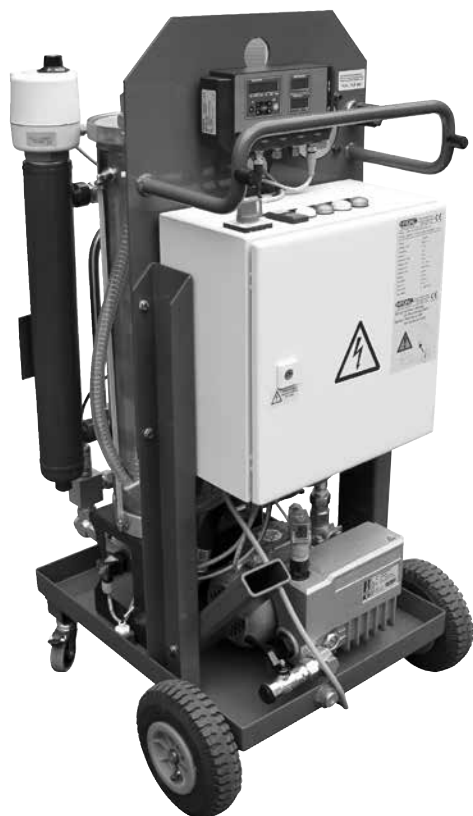

Description

The Fluid Aqua Mobile FAM 5 is designed for dewatering, degassing and filtering hydraulic and lubrication fluids.

It operates on the principle of vacuum dewatering to eliminate free and dissolved water as well as free and dissolved gases. By using HYDAC Dimicron filter technology which has a high contamination retention capacity and filtration efficiency, the FAM 5 is extremely cost effective.

Its compact and mobile design makes it ideally suited for service work. The version designed for permanent installation provides continuous protection for applications where operating fluids require optimal conditioning, where valuable bio-oils or fire-resistant operating fluids are used, or where water frequently gets into the system.

Features

- Small, compact and easy-to-use unit for prompt deployment during service calls or emergencies
- Reliable and convenient for fixed and permanent use due to extensive monitoring functions
- Optional integrated heater to increase dewatering performance, especially for cold or high viscosity oils
- Optional integrated water content and particle measurement technology with continuous display of the measurements and storage of the values
- Very low residual water content, gas content and particle contamination result in longer oil change intervals, improved life expectancy of components, higher machine availability and as a result, a reduction in the Life Cycle Cost (LCC)

Applications

- Steel and rolling mills
- Pulp and paper plants
- Power generation plants
- Tool machines / Plastic machines
- Hydraulic operated presses
- Oil conditioning

Technical Specifications

Flow rate at 50 Hz	≈ 5 l/min
Permitted fluids**	Fluids compatible with NBR seals: <ul style="list-style-type: none"> • Mineral oils to DIN 50524 • Gear oils to DIN 51517, 51524 Operating fluids compatible with FPM (FKM, Viton®) seals: <ul style="list-style-type: none"> • Synthetic esters (HEES) DIN 51524/2 • Vegetable oils (HETG, HTG) • HFD fluids (<i>not for pure phosphate esters which require EPDM seals</i>)
Sealing material	NBR or FPM (see model code "Operating fluid")
Filter size of fluid filter	OLF 5
Filter element for fluid filter (xxx = filtration rating)	N5DMxxx Filter element must be ordered separately, (see table "Filter elements for fluid filters")
Clogging indicator	Differential pressure switch with cut-off function when filter is clogged
Type of vacuum pump	Rotary vane vacuum pump
Pump type for filling & draining	Gear pump
Operating pressure	0 to 116 psi (0 to 8 bar)
Permissible pressure at suction port (without suction hose)	-2.9 to 14.5 psi (-0.2 to 1 bar)
Permissible operating viscosity range**	78 to 1623 SUS (15 to 350 mm ² /cSt) (w/o integrated heater) 78 to 2550 SUS (15 to 550 mm ² /cSt) (with integrated heater)
Permitted viscosity range for particle measurement	78 to 297 SUS (15 to 200 mm ² /cSt) (with ACS measuring equipment)
Fluid temperature range**	50 to 176 °F (10 to 80 °C)
Ambient temperature **	32 to 104 °F (0 to 40 °C)
Storage temp. range**	32 to 104 °F (0 to 40 °C)
Relative ambient humidity**	Maximum 90%, non-condensing
Electrical power consumption (without heater) / required external fuse*	≈ 1 kW / 16 A for circuit breakers with trip characteristics type C
Heating output (optional)	Max. 2.4 kW (depending on the nominal voltage, see model code)
Protection class	IP54
Length of power cable / plug	10 m / CEE (depending on the nominal voltage, see model code)
Length of connection hoses	197" (5 m) (mobile version only)
Material of hoses	see Model Code
Hydraulic connections	see table "Connection Summary"
Weight when empty	~26.5 lb. (~120 kg)
Achievable residual water content	< 100 ppm - Hydraulic and lube oils < 50 ppm - Turbine oils (ISO VG 32/46) < 10 ppm - Transformer oils ***

*Maximum specifications given, depends on equipment

**For other fluids, viscosities or temperature ranges, please contact HYDAC

***Units are not suitable for "Online" and "Onload" operation (transformer in operation and connected to grid).

Model Code

FAM - 5 - M - 2 - E - 05 - R - H - B - ACS - 00/-V

Series

FAM = Fluid Aqua Mobile

Size

5 = ~ 1.32 gpm (~ 5 l/min)

Operating fluid

- M = Mineral oil - NBR seals, NBR hoses, tested with mineral oil*
- I = Insulating oil - NBR seals, NBR hoses, tested with insulating oil (e.g. Shell Diala)* / **
- X = HFD-R fluids - Fluroelastomer (FPM) seals, UPE/PE-PA hoses, tested with HFD-R fluid (e.g. Fyrquel)*
- B = Biodegradable (ester-based) - Fluroelastomer (FPM) seals, NBR hoses, tested with biodegradable operating fluid based on esters*

Mechanical type

- 1 = Stationary (*with feet*)
- 2 = Mobile (*with castors and connection hoses*)

Voltage / Frequency / Power supply

- E = 220 V/60 Hz/3Ph+PE
- M = 230 V/50 Hz/1Ph+PE
- O = 460 V/60 Hz/3Ph+PE¹⁾
- AD = 220 V/60 Hz/1Ph+PE
- X = other voltage on request

Filter Size of Fine Filter

05 = OLF5

Type of Vacuum Pump

R = Rotary vane vacuum pump

Heater

- H = Heater
- Z = Without heater (*for 200 to 359 V = 1 kW, for 360 to 690 V = 2.4 kW, heater only possible from 200 V*)

Control Concept

B = basic

Measuring Equipment

- Z = without
- AD = Aqua Sensor (AS 3000), (with display directly on the sensor), without control function.
- ACS = Aqua Sensor AS 1000 + Contamination Sensor CS 1000 + Sensor Monitoring Unit (SMU 1200).
Display and storage of the measurements, without control function.

Modification Number

00 = The latest version is always supplied.

Supplementary Details

- None = standard
- V = Fluroelastomer (FPM) seals for "M" and "I" fluids

1) Supplied without connector

* Residues of test fluid will remain in the unit after testing

** Units not suitable for "Online" and "Onload" operation (*transformer in operation and connected to grid*)

For replacement element part numbers, please see Section E - REPLACEMENT ELEMENTS of this catalog.

OFFLINE FILTRATION SYSTEMS

Hydraulic Schematic

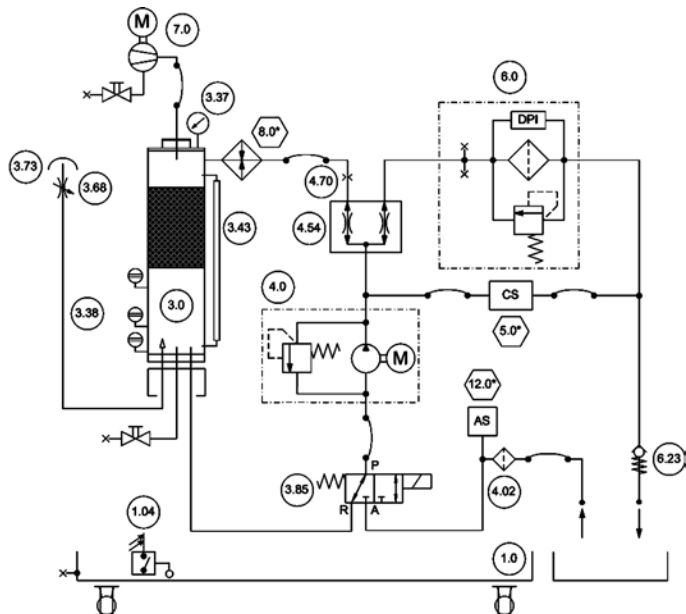

Item	Description
1.0	Drip tray
1.04	"Drip pan full" float switch
3.0	Vacuum column
3.38	Level sensor for vacuum column
3.68	Needle valve to regulate the necessary vacuum in the vacuum column
3.73	Breather filter
3.85	3/2 directional valve
4.0	Motor pump assembly
4.02	Suction screen
4.54	Flow divider
5.0	ContaminationSensor CS1000 (optional)
6.0	Fluid filter for elimination of solid particles, with differential pressure switch for filter monitoring
7.0	Vacuum pump
8.0	Heater (optional)
12.0	AquaSensor AS 1000 / AS 3000 (optional)



Type of vacuum pump

The vacuum pump used is an oil lubricated rotary vane pump.

The air discharged by the vacuum pump can, in addition to water, contain constituent elements of the operating fluid concerned, as well as any gases it contained.

Therefore, please ensure that the area in which the FAM is operated is adequately ventilated.

Dimensions Stationary

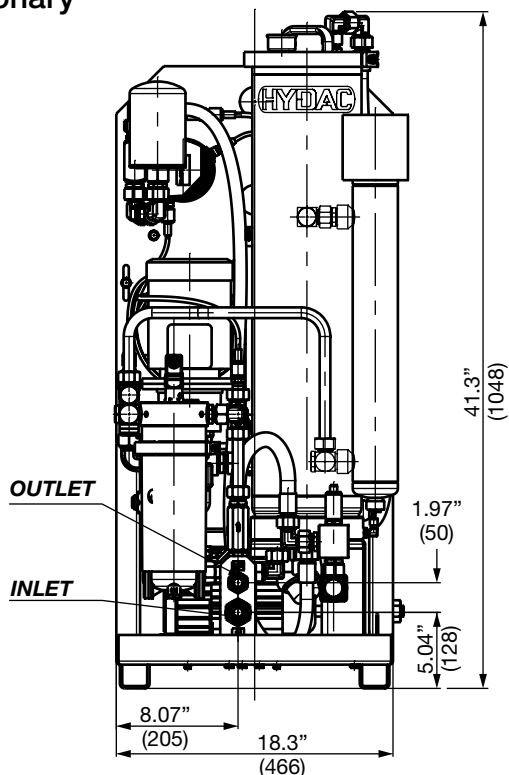

Mobile

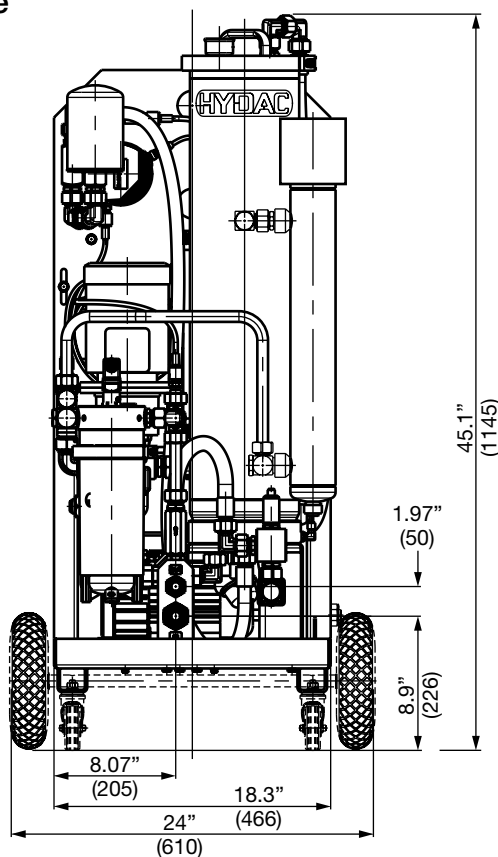

Dimensions are for general information only, all critical dimensions should be verified by requesting a certified print.

Sizing

As a rough guide, the FluidAqua Mobil can be sized according to the tank volume of the system.

Tank Volume (gallons)	Model
< 396 (< 1,500 L)	FAM 5

In general, it must however be noted that sizing will depend on the application, the fluid, the temperature of the fluid and the ambient temperature, the fluid quantity and the water ingress into the system. These have a great effect on the dewatering efficiency. Therefore the specifications can only serve as an indication.

Factors That Affect Water Removal Rate

	Factor (increasing/decreasing)	Dewatering Speed
Water Content	↑	↑
Fluid Temperature*	↑	↑
Detergent Additives	↑	↓
FAM Flow Rate	↑	↑

Connection Summary

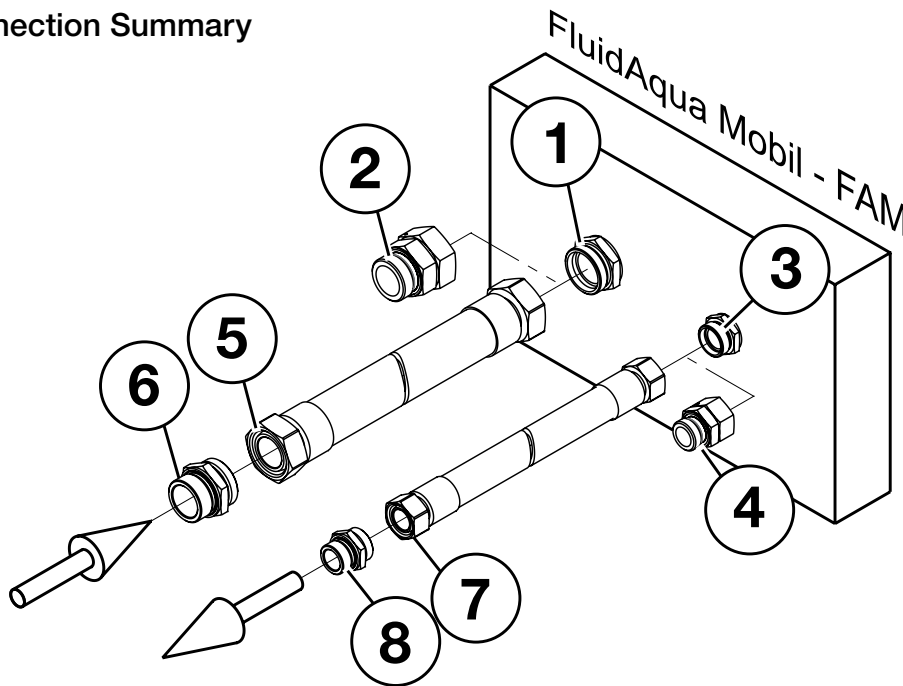

Item	FAM 5
1 - FAM inlet connector	28L / M36x2 (male thread)*
2 - Adapter	Adapter G1 A (male thread)**
3 - FAM outlet connector	18L / M26x1.5 (male thread)*
4 - Adapter	Adapter G ½ A (male thread)**
5 - Suction hose connection	28L / M36x2 (female thread)***
6 - Adapter	Adapter G1 A (male thread)**
7 - Pressure hose connection	18L / M26x1.5 (female thread)***
8 - Adapter	Adapter G ½ A (male thread)**

* Connection Form D to ISO 8434-1 Series L
(corresponds to ISO 12151, Form S, Series L)

** Screw-in spigot to ISO 1179-2 (Form E)

*** Connection Form N to ISO 8434-4 Series L
(corresponds to ISO 12151, Form SWS, Series L)

Items 1 to 4 are supplied with the stationary FAM.

Items 1 to 8 are supplied with the mobile FAM.

Heater

By using the built-in heater, the dewatering capacity can be increased, particularly in the case of high viscosity fluids or fluids at low temperatures.

If the temperature of the fluid is raised by 50°F(10°C) then the dewatering capacity increases by up to 50 %. The ideal temperature for dewatering is ~122 to 140°F (~50 to 60°C).

Generally speaking, for operating viscosities of between 2086 to 3708 SUS (350 to 800 mm²/cSt) the heater option must be selected and the heater must be used.

Instrumentation

If the water and particle measuring options (*AquaSensor* and *ContaminationSensor*) are included, it is possible to display the water content relative to the saturation point (*saturation level, relative humidity*), as well as the particle contamination and temperature of the fluid. The measured data is stored in the SensorMonitoring Unit with a date and time stamp and can be easily transferred using a USB memory stick.

Accessories

Description	Material	Part No.
Lance set for suction and return hose, consisting of: 2x lances ø0.71" (ø18 mm), length = 19.7" (0.5 m)	FPM	3685146

Items supplied

- Fluid Aqua Mobile
- With suction and return hose (*only on mobile version*)
- 0.26 gal. (1L) vacuum pump oil for initial filling of vacuum pump
- Control cabinet key
- Technical documentation:
 - Operating and Maintenance Manual
 - Electrical wiring diagram
 - Test certificate
 - CE declaration of conformity

OFFLINE FILTRATION SYSTEMS

FAMH Series

Vacuum Dehydrator - Water & Solid Removal



Hydraulic Schematic

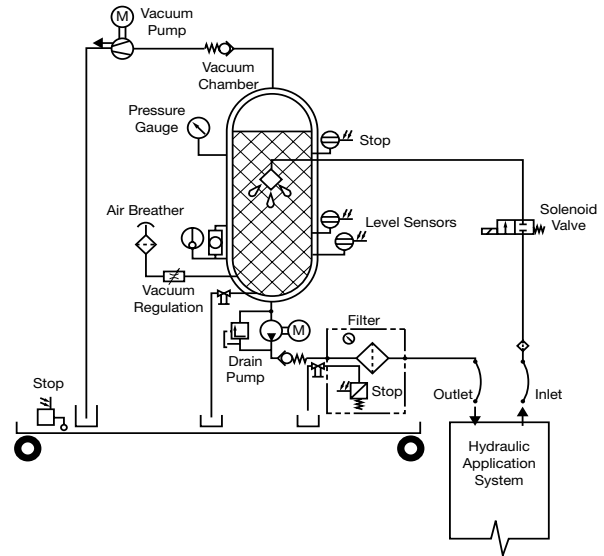

Description

The dewatering and filtration unit FAMH is a bypass unit which has been specially designed for the conditioning of lubrication and hydraulic fluids. Use of HYDAC's Dimicron® filter element technology provides a high contamination retention capacity.

The FAMH has been redesigned to include a touch screen menu for ease of diagnostics.

Advantages

- Nema 12 Standard
- Separation of 100% free and 90% dissolved water through vacuum dehydration
- Removal of 100% free and 95% dissolved gases
- Separation of particles with high contamination retention capacity
- Easy handling and automatic supervision of the PLC controlled process
- User friendly touch screen diagnostics
- Standard aquasensor provides % water saturation
- JIC connections

Applications

- Steel and rolling mills
- Pulp and paper plants
- Power generation plants
- Tool machines / Plastic machines
- Hydraulic operated presses
- Oil conditioning

Options

- Nema 4 Enclosure

HYDAC FAMH vs Other

- Water removal below saturation point
- Static flow through the filter
- Optimal particle removal efficiency
- No corrosion within the vacuum pump
- Low operating costs
- User friendly on screen operational and maintenance instructions

The contamination of hydraulic fluids with water can either be caused by condensation or by ingress. Variations in temperature of the hydraulic tank lead to condensation. The ingress of water can be caused by defective cooler hoses, defective seals or external leakages into the system.

In lubrication and hydraulic fluids water can occur in two different forms:

- free water (*visible*)
- dissolved water (*not visible*)

Aquamicon® elements, centrifuges and condensation methods normally only separate free water, the FAMH separates both forms of water from the oil. While dewatering the fluid, dissolved gases are also removed. Thereby the lubricating properties are improved which extends oil life, reduces component wear rates, and eliminates production losses caused by breakdowns.

OFFLINE FILTRATION SYSTEMS

Technical Specifications

Series	FAMH 15	FAMH 30	FAMH 50	FAMH 70
Filter Size	OLF-15	OLF-30	OLF-45	OLF-70
Filter Element	N15DMxxx(1x)	N15DMxxx(2x)	N15DMxxx(3x)	N15DMxxx(5x)
Capacity of Pressure Vessel gal (liters)	5.25 (20)	10.5 (40)	20.5 (78)	26.25 (100)
Approx. Solid Contamination removal to ISO 4572 lbs (g)	1.1 (500)	2.2 (1000)	3.3 (1500)	5.5 (2500)
Electric Clogging Indicator	VM 2C.x			
Bypass Cracking Pressure psi (bar)	29 (2)			
Pump Type	Gear pump			
Flow rate gpm	5	10	16	23
Maximum Operating Pressure psi (bar)	87 (4.5)			
Viscosity Range (without) SUS (cst)	75-2500 (15-500)			
Electrical Cable Length ft (m)	32 (10)			
Hose Length ft (m)	16 (5)			
Hose Material	NBR			
Inlet - Outlet	JIC 20 (1 1/4") - JIC 16 (1")			
Seal Material (FPM for operating fluid B, X)	NBR			
Dry Weight (lbs.)	940	970	1100	1145
Fluid Temperature	50° to 175°F			
Ambient Temperature	5° to 105°F			
Attainable water content (ppm)	< 100 ppm			
Power Requirements	60 AMP Circuit Required			

Dimensions

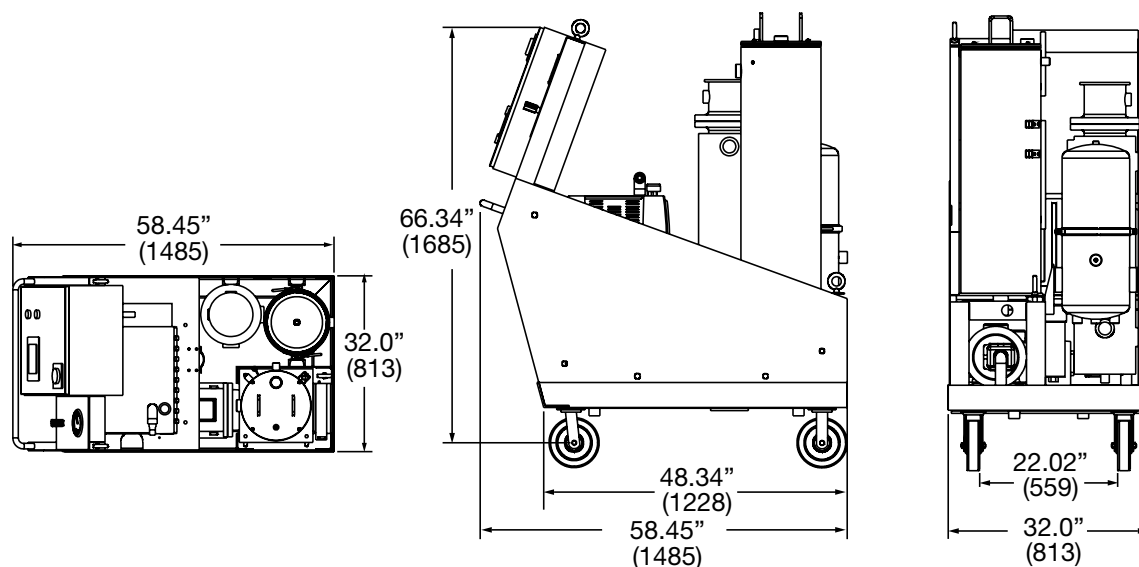

Dimensions are for general information only, all critical dimensions should be verified by requesting a certified print.

Water Extraction Process

(for FAMH 15 - 70 without heater only)

The operating fluid is drawn from the oil reservoir by the vacuum in the reactor through the suction strainer and the shut-off valve. The oil trickles down slowly and from there is fed back into the oil reservoir by the gear pump through the filter. When Dimicron filter element technology is used the unit is especially economical.

Water is removed from the fluid in the reactor. The vacuum present has the effect of reducing the boiling point of the water.

The water vapor is released into the atmosphere or the water reservoir through the vacuum pump.

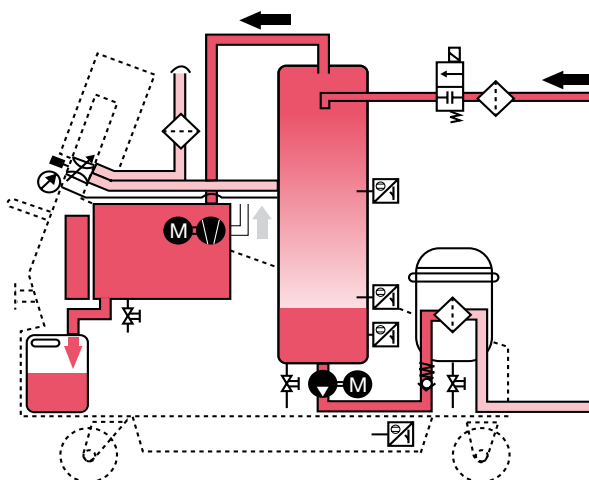

Negative Effects of Water on Oils

It is almost certain that there is water in a hydraulic system. The most frequent causes are: ambient humidity, splash water, and new oil. Mineral based oils show a faster aging process, if there is water in the oil. This aging process is accelerated through contamination particles by a catalytic effect. The additives are quickly used up and the lifetime of the operating fluid is much shorter than that of "dry" oil.

Water in Mineral Oil causes

- Aging of the fluid
- Fluid deterioration
 - Reduced air separating results in: Cavitation
 - Increased foaming results in: Cavitation
 - Reduced lubrication results in: Vibration & Wear
 - Erratic operation results in: Inaccuracy
- Depletes additives
- Clogged filters
- Corrosion

Water in Ester Oils causes:

- Hydrolysis
- Seal deterioration
- Leakage

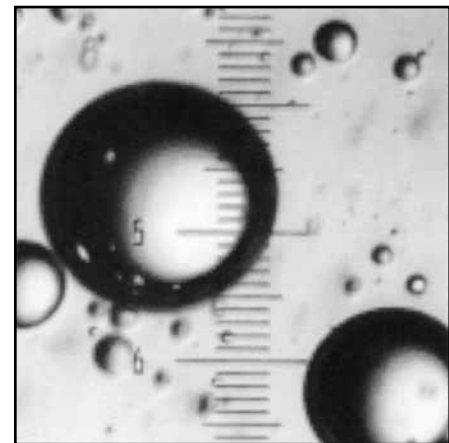

Tiny water droplets in hydraulics fluid
(1 unit equals 10 micron)

Typical Saturation Limit of Hydraulic Oil for Water

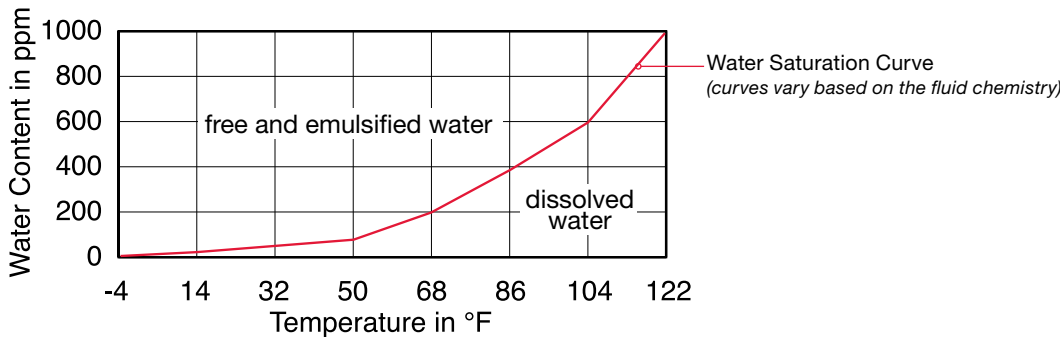

FAMH Sizing

Sizing of the FAMH is normally done through periodic measuring of the water content which will determine the hourly ingress of water. The typical dewatering speed of the FAMH is listed in the technical data table. If there is a continuous ingress of water the recommended flow rate of the FAMH can be determined by the system size (*total gallons*).

Sizing Chart Limits

(continuous water ingress)

Tank Volume (gallons)	FAMH Model
1000 to 2000	FAMH 15
2000 to 4000	FAMH 30
4000 to 7000	FAMH 50
7000 and up	FAMH 70

*Please note that the fluid temperature should be a minimum of 20°F warmer than the ambient air temperature to enable efficient dewatering. An inline heater is available for reclaim applications. Please contact our sales/technical department.

Factors That Affect Water Removal Rate

	Factor (increasing/decreasing)	Dewatering Speed
Water Content	↑	↑
Fluid Temperature*	↑	↑
Detergent Additives		↓
Absolute Pressure in Vacuum Chamber	↓	↑
Humidity	↓	↑
FAM Flow Rate	↑	↑
Ester Oils		↘

OFFLINE FILTRATION SYSTEMS

HTB Series

Hydraulic Test Bench

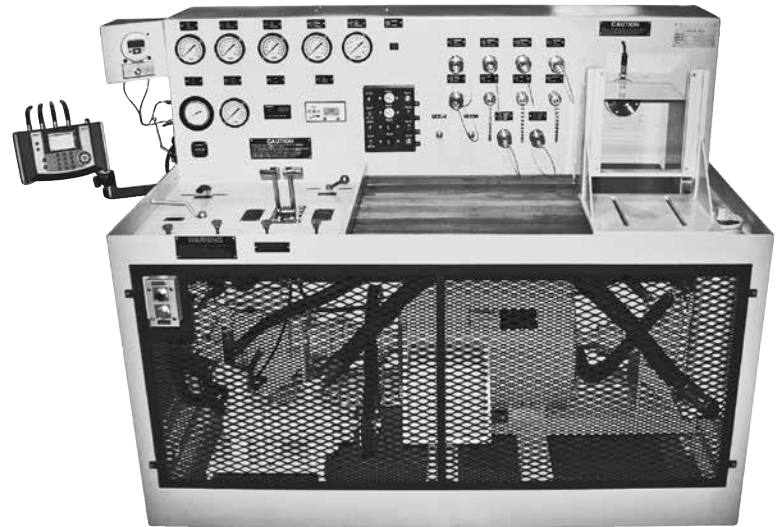
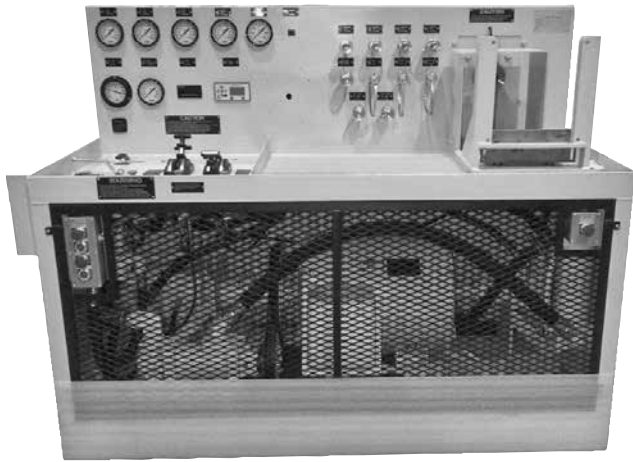

Description

The HYDAC HTB hydraulic test bench is the ultimate diagnostic tool, capable of thoroughly testing a vast array of new or rebuilt components and subassemblies prior to their installation in a working system. Test bench instrumentation has been designed to make diagnosis fast and accurate, with virtually no requirement for connecting external instruments. The bench panel includes a digital flow gauge, a tachometer to measure the speed of tested pumps or motors, and a reservoir temperature gauge. Individual gauges measure pressure on the test bench main pump, the pump or motor being tested, the test bench load pump, the cylinder and valve pressure port, and the test bench super charge pump.

Every HTB includes efficient HYDAC hydraulic filters to keep the bench oil at optimum cleanliness, providing assurance that newly rebuilt components will not be subjected to harmful levels of dirt. To keep filters operating at peak efficiency, the instrument panel includes a red pilot light that signals the operator when any bench filter needs a new element.

These benches have been refined for over 30 years by HYDAC engineers, based on the comments and requests of over 700 test bench owners. The versatile hydraulic circuitry present in each of the three models can shorten troubleshooting time and take the guesswork out of diagnoses. Current models are powerful, compact units that pay for themselves quickly in saved maintenance time and expenses.

Applications

- **Pumps and motors** can be tested dynamically. Pump and motor testing is aided by the wide speed and torque ranges built into the bench and by the universal mounting bracket and mounting accessories that come with the bench. An open loop hydrostatic variable volume hydraulic system provides the power and speed control for the drive shaft. Motors can be dynamically tested, under load, for operating efficiency. Pumps can be tested for external leakage and volumetric efficiency in either direction, at speeds from 100 to 2400 rpm. The test bench can also be used to break-in pumps and motors to manufacturer's specifications before they are installed in a system.
- **Cylinder** leaks are easy to find. Double-acting cylinders may be cycled, and tested for both internal and external leakage at any point of piston travel. Scored cylinder walls and defective packing are easily detected. Single-acting cylinders are tested at maximum stroke.
- **Valve** testing time is minimized. Pressures can be set, external and internal leakage spotted, flow and pressure data can be generated and checked against operating requirements and overall valve efficiency determined. Optional electrical and pilot pressure supplies are available on the bench for testing solenoid-actuated and pilot-operated valves.

Features

- An ingenious universal mounting bracket makes mounting pumps and motors on the bench a simple, quick operation
- Mounting plates are furnished to accommodate flange-mounted and foot-mounted pumps or motors
- Drive adapter equipment includes inserts for keyed shafts, an insert chuck and a universal drive shaft
- Quick disconnect porting on the bench provides convenient hook-up for test components
- Includes a factory-trained technician for a two-day, on-site training session
- Two complete operating manuals are supplied with each bench
- Kits and spare parts available for upgrades and maintenance

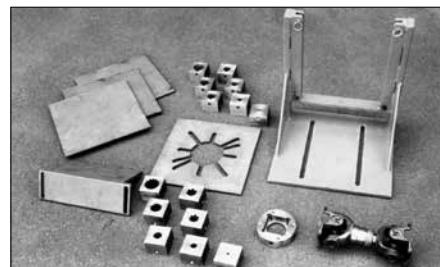
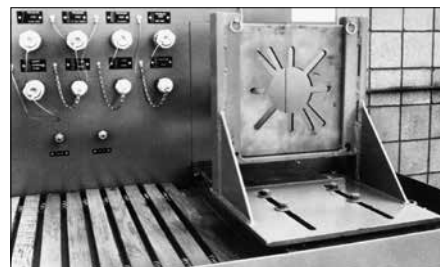

Model Code

HTB 100 A AD

Series

HTB = Hydraulic Test Bench

HP

50, 100, 150

Voltage

A = 230V 60Hz, B = 460V 60Hz, C = 575V 60Hz, D = 380V 50Hz, E = 415V 50Hz, F = 380V 60Hz

Options

A = Water Cooled Heat Exchanger	G = Closed Loop Circuit
B = Solenoid & Pilot Operated Valve Group	H = HMG Digital Electronic Group
C = Jib Crane Group	I = Air Cooled Heat Exchanger
D = Filtration Group (included on all HTB's)	J = 25 GPM Case Drain Meter
E = Safety Enclosure Group	K = Digital Gauges
Splined Shaft Group*	L = CS1000 Kit
	Hose & Fitting Group*

*Note: Ordered as a separate line item.

Model Codes containing RED are non-standard items - Minimum quantities and longer lead times may apply - Contact HYDAC for information and availability.

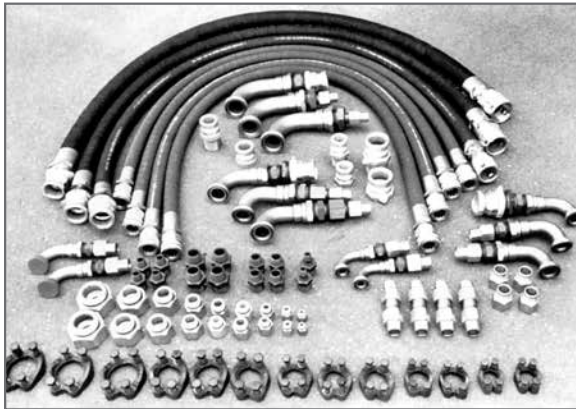

Hose and Fittings Group Option

(contains hose connection with female quick disconnects on both ends, plus a series of separate national pipe thread, straight thread, and SAE four-bolt flange adapters, ranging in size from 3/8" through 2", equipped with male quick disconnects)

Features	Model HTB-50-E	Model HTB-100-E	Model HTB-150-E
Speed Range in either direction	200 to 2400 rpm	200 to 2400 rpm	200 to 2400 rpm
Power Available for testing pumps Expressed torque	275 ft-lbs to 1200 rpm	458 ft-lbs to 1200 rpm <i>(decreasing proportionately to 2400 rpm)</i>	670 ft-lbs to 1200 rpm
Expressed in horsepower	60 hp at 1200 rpm	115 hp at 1200 rpm <i>(with constant hp to 2400 rpm)</i>	150 hp at 1200 rpm
Test Pressure	0 to 5000 psi (345 bar)	0 to 5000 psi (345 bar)	0 to 5000 psi (345 bar)
Test Motor Load Maximum in either direction	275 ft-lbs (373 Nm)	458 ft-lbs (621 Nm)	670 ft-lbs (908 Nm)
Electrical Drive Motor-230/460V, 1800 rpm; 3 phase, 60 hertz (A start-stop push button is mounted on the bench; Starter(s) is/are not included. Customer must advise type of starter(s) and service voltage he will use.)	50 hp	100 hp	100 hp and 50 hp
Hydraulics			
Main Bench Pump (variable piston)	23 gpm/5000 psi (87 L/min/345 bar)	38 gpm/5000 psi (144 L/min/345 bar)	38 gpm/5000 psi (144 L/min/345 bar)
Auxiliary Main Pump (variable piston)	N/A	N/A	23 gpm/5000 psi (87 L/min/345 bar)
Supplemental Pump	20 gpm/2000 psi (76 L/min/138 bar)	20 gpm/2000 psi (76 L/min/138 bar)	20 gpm/2000 psi (76 L/min/138 bar)
Pressure and Return Ports	1" quick disconnects	1" quick disconnects	1" quick disconnects
Suction Porting	1" & 2" quick disconnects	1" & 2" quick disconnects	1" & 2" quick disconnects
Flow Gauge Scales	Three Scales: 2 to 14; 8 to 36; 24 to 100 gpm (all models)		
Reservoir Capacity	100 gallons (378 L)	100 gallons (378 L)	200 gallons (757 L)
General	Full flow 3 micron filtration maintains excellent system cleanliness level; bench includes a 30" x 30" work pan, oil level gauge, fill cap mesh strainer, digital tachometer.		
Bench Dimensions and Weight	62" H x 76" L x 43" W 4100 lbs (1860 kg)	62" H x 76" L x 43" W 4500 lbs (2041 kg)	62" H x 76" L x 55" W 6000 lbs (2722 kg) Auxiliary Power Unit 30" H x 50" L x 30" W 900 lbs (408 kg)

OFFLINE FILTRATION SYSTEMS

Notes

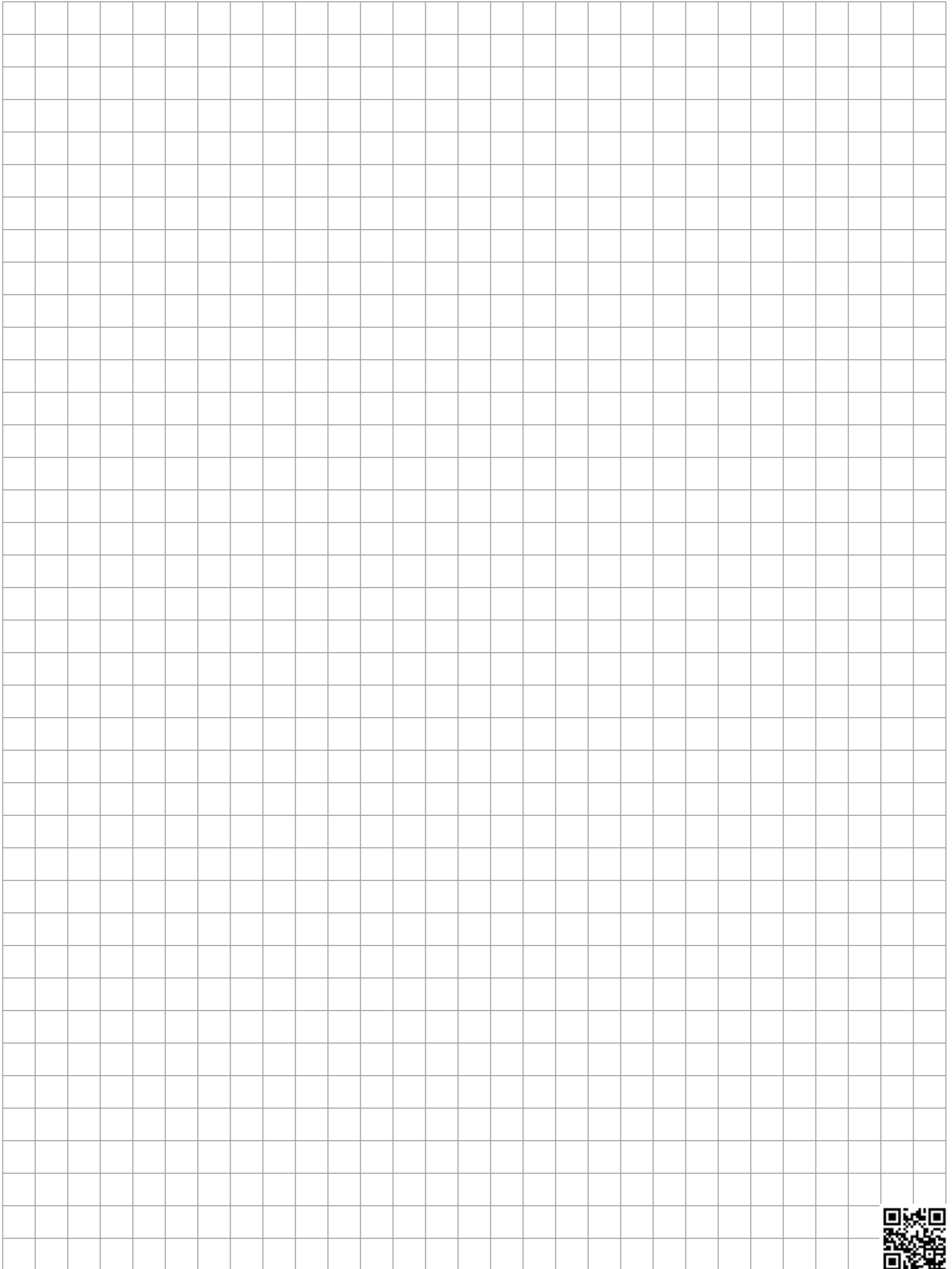
A large grid of graph paper for taking notes, consisting of 20 columns and 30 rows of small squares.

E Replacement Elements

Each of our hydraulic filtration systems are equipped with high efficiency elements to remove solid particulates and/or water quickly and efficiently. A complete listing of the replacement elements used through-out the Filter Systems catalog can be found on the following pages.

REPLACEMENT ELEMENTS

Pressure Elements

Used in OFS Series, OFCS & OFCD Series, OFAS & OFAD Series, OF5HS & OFCD-HV Series, and OFX Skid - Standard Capacity Series

9 inch Elements		18 inch Elements		27 inch Elements	
Model Code	Part No.	Model Code	Part No.	Model Code	Part No.
5.03.09D03BN	02060528	5.03.18D03BN	02060430	5.03.27D03BN	02065003
5.03.09D03BN/-V	02056713	5.03.18D03BN/-V	02071680	5.03.27D03BN/-V	02082855
5.03.09D05BN	02060529	5.03.18D05BN	02060431	5.03.27D05BN	02065004
5.03.09D05BN/-V	02056714	5.03.18D05BN/-V	02056457	5.03.27D05BN/-V	02073488
5.03.09D10BN	02060530	5.03.18D10BN	02060432	5.03.27D10BN	02065005
5.03.09D10BN/-V	1278599	5.03.18D10BN/-V	02056492	5.03.27D10BN/-V	02056493
5.03.09D20BN	02060531	5.03.18D20BN	02060433	5.03.27D20BN	02065006
5.03.09D20BN/-V	1294016	5.03.18D20BN/-V	02072428	5.03.27D20BN/-V	02096052
5.03.09D40AM	02075265	5.03.18D40AM	02091879	5.03.27D40AM	02088358
—	—	—	—	5.03.27D40AM/-V	02088359
—	—	—	—	—	—
5.03.09D10BN/AM	02075258	—	—	—	—
5.03.09D40AM/-V	02561740	—	—	—	—
HK/HJ (connector element)	7630900	—	—	—	—

Element Performance

Micron Rating	Filtration Rating per ISO 4572/NFPA T3.10.8.8 <i>Using automated particle counter (APC) calibrated per ISO 4402</i>			Filtration Rating wrt ISO 16889 <i>Using APC calibrated per ISO 11171</i>	
	Bx≥75	Bx≥100	Bx≥200	Bx≥200	Bx≥1000
Element					
5	2.5	3.0	4.0	4.8	6.3
10	7.4	8.2	10.0	8.0	10.0
25	18.0	20.0	22.5	19.0	24.0

Dirt Holding Capacity

9" Element Micron Rating	DHC(gm)	18" Element Micron Rating	DHC(gm)
5	119	5	238
10	108	10	216
25	93	25	186

Used in OFCD-MV Series, OFS-AM Series, OF5HD-HV Series, MAFH-E Series

18 inch Element		27 inch Element	
Model Code	Part No.	Model Code	Part No.
5.03.18D03BN/-V-G	02094523	5.03.27D03BN/-V-G	02098195
5.03.18D05BN/-V-G	02094528	5.03.27D05BN/-V-G	02200583
5.03.18D10BN/-V-G	02094529	5.03.27D10BN/-V-G	02200584
5.03.18D20BN/-V-G	02098097	5.03.27D20BN/-V-G	02200585
5.03.18D10AM/-V-G	02097600	5.03.27D40AM/-V-G	02098194

Note: G = Betamicron GeoSeal® (r) replacement elements

Element Performance

Micron Rating	Filtration Rating per ISO 4572/NFPA T3.10.8.8 <i>Using automated particle counter (APC) calibrated per ISO 4402</i>			Filtration Rating wrt ISO 16889 <i>Using APC calibrated per ISO 11171</i>	
	Bx≥75	Bx≥100	Bx≥200	Bx≥200	Bx≥1000
Element					
3	<1.0	<1.0	<2.0	4.0	4.8
5	2.5	3.0	4.0	4.8	6.3
10	7.4	8.2	10	8.0	10.0

Dirt Holding Capacity

18" Element Micron Rating	DHC(gm)	27" Element Micron Rating	DHC(gm)
3	230	3	345
5	238	5	357
10	216	10	324

Used in OFX Skid - High Capacity Series

16 inch Element		39 inch Element	
Model Code	Part No.	Model Code	Part No.
1.14.16D03BN	1252836	1.14.39D03BN	1252840
1.14.16D03BN/-V	1252837	1.14.39D03BN/-V	1252841
1.14.16D06BN	1252838	1.14.39D06BN	1253294
1.14.16D06BN/-V	7602185	1.14.39D06BN/-V	2094525
1.14.16D12BN	1253292	1.14.39D12BN	1253295
1.14.16D12BN/-V	C/F	1.14.39D12BN/-V	02071197
1.14.16D25BN	1253293	1.14.39D25BN	1253384
1.14.16D25BN/-V	1252839	1.14.39D25BN/-V	C/F

Used in MAFH-A Series

Model Code	Part No.
5.12.09D10BN/-V	02561354
5.12.09B03BN/-V	02093367
5.12.09B05BN/-V	02091885
Breather Element (<i>Shrouded</i>)	02561357
Breather Element (<i>Cart</i>)	1296639

Element Performance

Micron Rating	Filter Rating	DHC (gm)
1	β 4.2(c) \geq 1000	55
3	β 4.8(c) \geq 1000	57
5	β 6.3(c) \geq 1000	62
10	β 10(c) \geq 1000	52

Used in IXU 1/4 Series

Model Code	Part No.
IXE 200	03348961
5.03.18D05BN/V SO103H	02077497
5.03.18D10BN/-V SO103H	02056369

Used in OFCD-BC Series, OF7-BC Series

Model Code	Part No.
ELEMENT OFCDBC 003	02099361
ELEMENT OFCDBC 005	02099362
ELEMENT OFCDBC 010	02099363
ELEMENT OFCDBC 020	02099364
ELEMENT OFCDBC AM	02099365

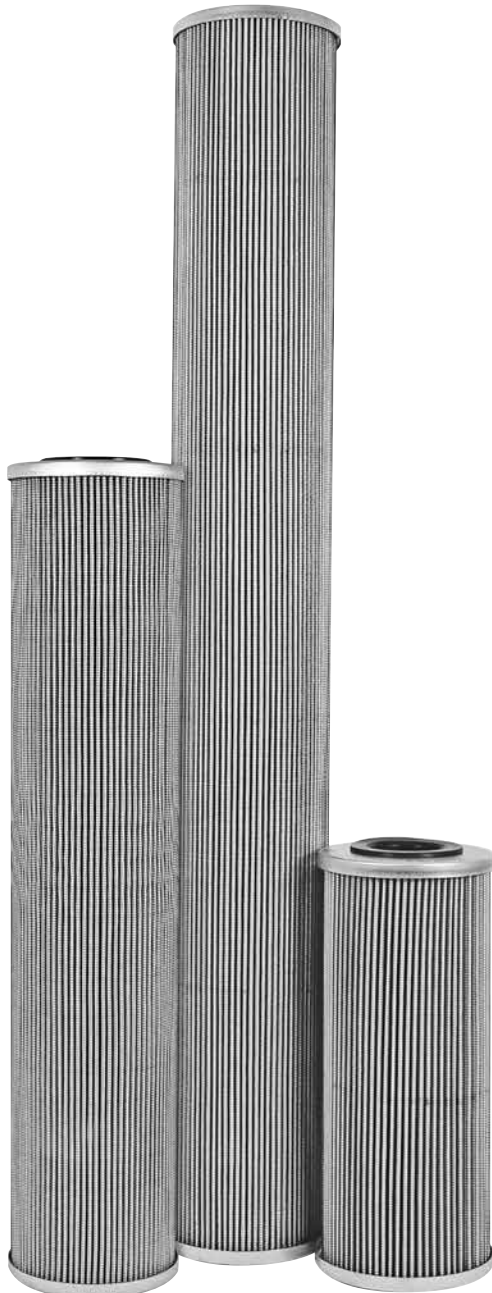

REPLACEMENT ELEMENTS

Dimicron® Elements

Used in OLF Series & FAMH Series

Model Code	Micron Rating	Part No.
N15DM002	2	01251590
N15DM010	10	03115180
N15DM020	20	00349576
N15DM030	30	03048790

Be sure to order the correct number of elements:
OLF 15 = 1, OLF 30 = 2, OLF 45 = 3, OLF 60 = 4



Cartridge Elements

Used in FAM5 & OLF Compact Series

Model Code	Micron Rating	Media Type	Part No.
N5DM002*	2	Dimicron®	00349494
N5DM005*	5	Dimicron®	03068101
N5DM010*	10	Dimicron®	03102924
N5DM020*	20	Dimicron®	03023508
N5AM002*	2	Aquamicron®	00349677
N5AM020*	20	Aquamicron®	03040345

*Cartridge element can not be used with OLF 5/4-SP



Aquamicron® (AM) Elements

Aquamicron® filter elements are specially designed to separate water from mineral oils. They are only supplied in the dimensions of HYDAC return line filter elements from size 330 and larger. This means that they can be installed in all HYDAC filter housings from size 330 which are fitted with return line filter elements.

The increasing pressure loss in a filter element which is being saturated with water indicates, by means of standard clogging indicators, that it is time to change the element. When the Aquamicron® technique is employed, particle contaminants are also separated from the hydraulic medium as a by-product. This means that the Aquamicron® element doubles as a safety filter. The "filtration rating" is 40 µm absolute ($\beta_{40} \geq 100$ to $\Delta p = 43.5$ psi / 3 bar).

In order to guarantee the greatest efficiency, it is recommended that these elements be installed in an off-line recirculation loop configuration.

For complete details please contact your HYDAC distributor.



Betamicron®/Aquamicron® (BN/AM) Elements

BN/AM filter elements are specifically designed to absorb water and achieve absolute filtration of solid particles from mineral oils, HFD-R oils, and rapidly biodegradable oils. A super absorber reacts with the water present in the fluid and expands to form a gel from which the water can no longer be extracted even by increasing the system pressure. These filter elements do not remove dissolved water below the saturation level of the hydraulic medium. Solid particle filtration (3 µm, 10 µm absolute) is achieved due to the Betamicron® filter construction.

For complete details please contact your HYDAC distributor.



Betterfit® Interchange Elements

HYDAC's family of interchange elements has a new name and a new focus. The former Betafit line will now be called Betterfit, and will incorporate an exclusive outer wrap that not only improves performance, but also provides quality protection. It features a unique oval-hole design that improves flow for more efficient filtration, ensuring long system life and cost savings. This is a one-of-a-kind oval design, so you can be assured that when your element includes this outer wrap that it is a HYDAC original and not a low quality imitation.





Reference Material

A quick reference of information and conversion charts to help guide you through this catalog.

REFERENCE MATERIAL

Viscosity Chart #1

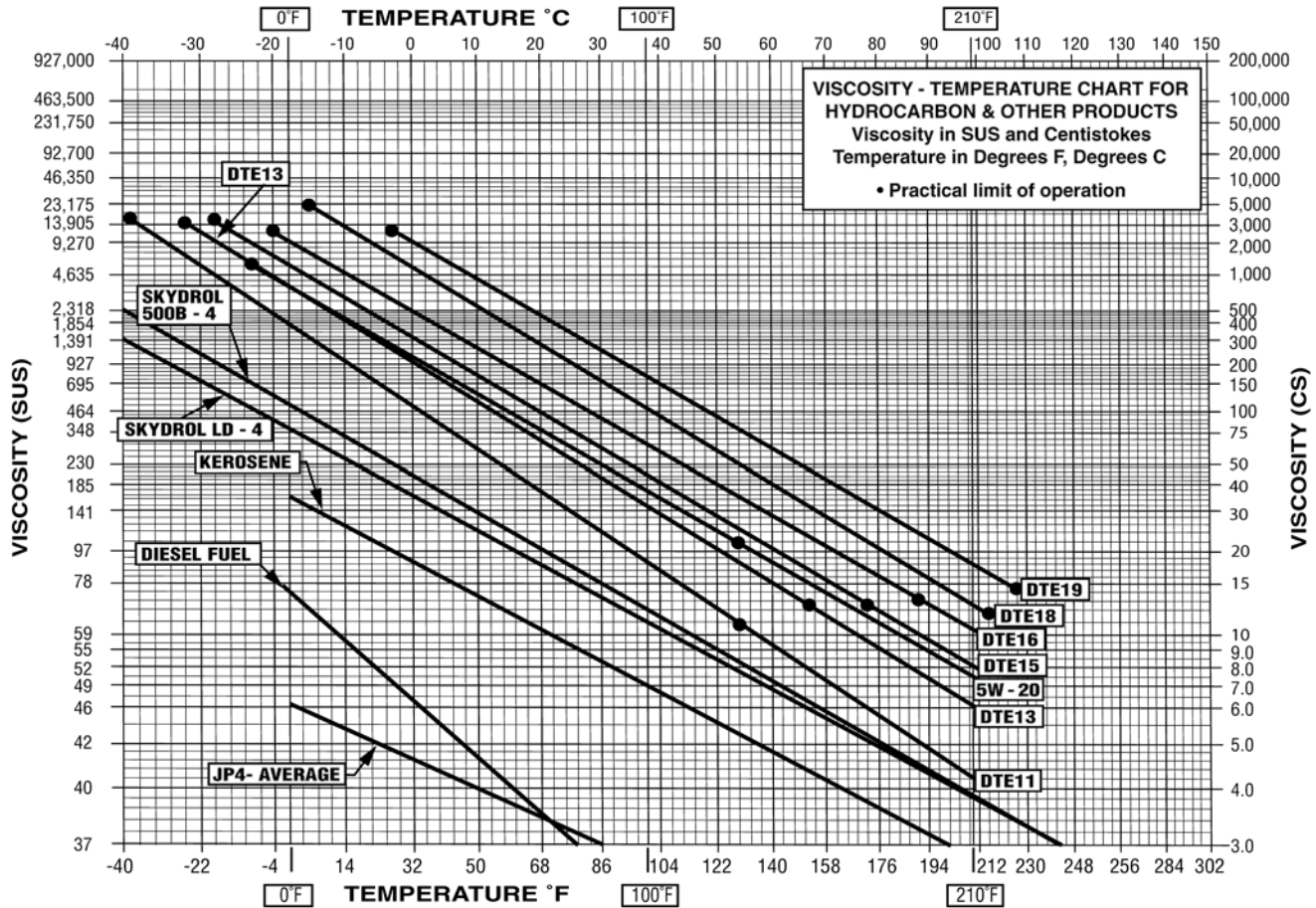

Viscosity Chart #2

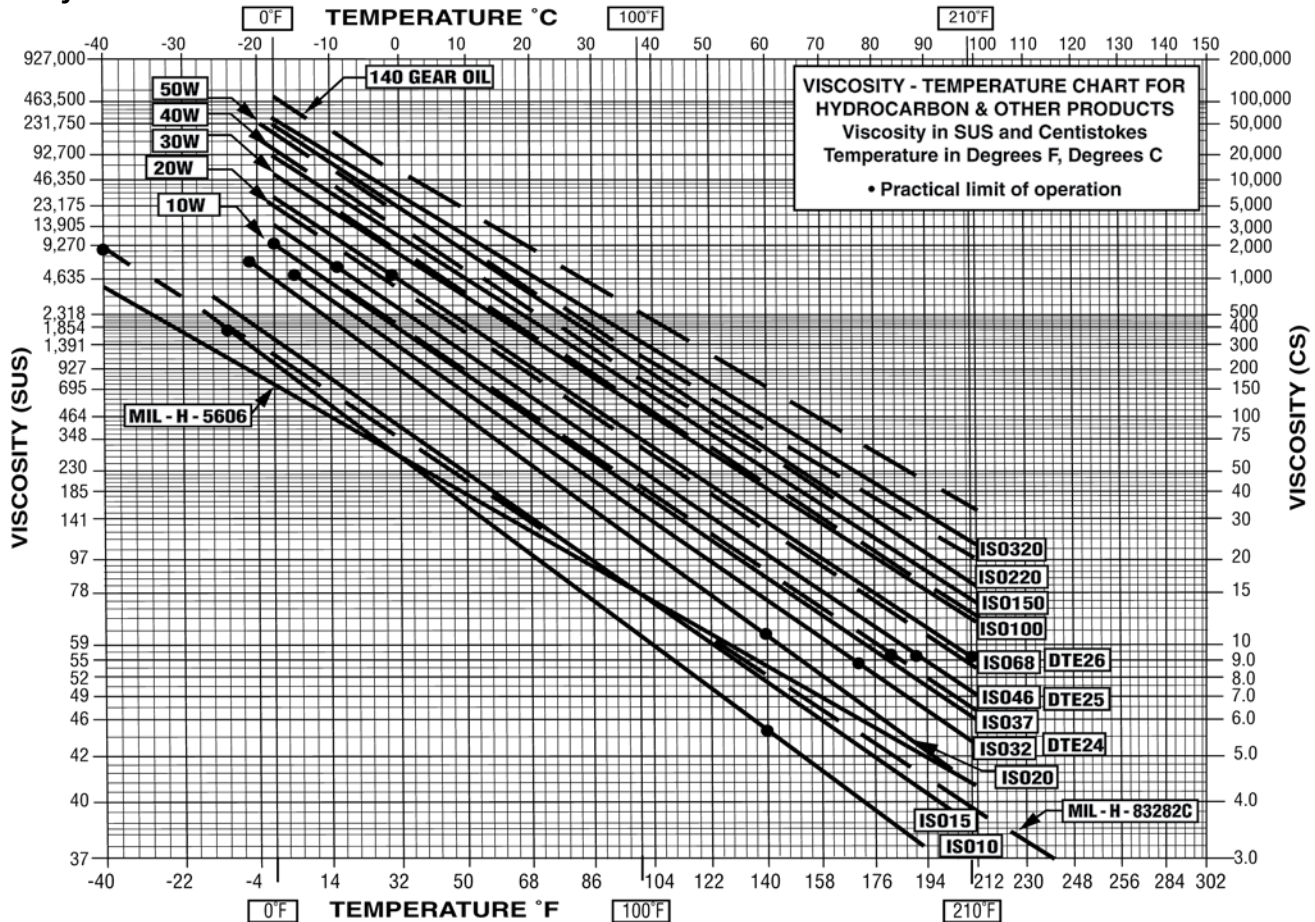

Ordering HYDAC Literature...

HYDAC literature is available for ordering via our website, www.hydacusa.com then click on the **Downloads** button to proceed with ordering printed copies *(digital versions excluded)* or email us at HYD.catalog@hydacusa.com using the appropriate Part Number (PN) and name. Other brochures, manuals and technical documents are also available when ordering from our website.



Overview Brochure
PN02088157



Filters Catalog
PN02081318



Accumulators Catalog
PN02068195

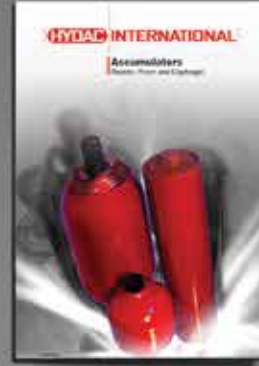

Compact Hydraulics
Catalog - PN02087369



Accessories Catalog
PN02080105



Standard Coolers
Catalog - PN02085359



Filter Systems Catalog
PN02075860



Electronics Catalog*
(online only)



Process Technology*
Catalog (online only)



Mobile Valves Catalog
PN02092408



Hydraulic Cylinders
Catalog (Release: TBD)



Control Technology*
Catalog (online only)



*These catalogs are digital file versions only.

Various market and product brochures are also available for ordering.



HYDAC TECHNOLOGY CORPORATION
HYDAC CORPORATION

2260 City Line Road
Bethlehem, PA 18017

+1.610.266.0100

HYD.catalog@hydacusa.com

www.hydacusa.com



Global Headquarters
HYDAC INTERNATIONAL
GMBH

Industriegebiet
D – 66280 Sulzbach/Saar
Germany

Tel.: +49 6897 509-01

Fax: +49 6897 509-577

Internet: www.hydac.com
Email: info@hydac.com

North America Locations

USA

www.HYDAC-NA.com

North America Headquarters
HYDAC TECHNOLOGY CORPORATION
Filter Division
2260 City Line Road
Bethlehem, PA 18017
+1.610.266.0100

HYDAC TECHNOLOGY CORPORATION
Electronic Division
Process Filter Division
HYDAC CORPORATION
Accumulator Division
90 Southland Drive
Bethlehem, PA 18017
+1.610.266.0100

HYDAC TECHNOLOGY CORPORATION
Accessory Division
2204 Avenue C
Bethlehem, PA 18017
+1.610.266.0100

HYDAC TECHNOLOGY CORPORATION
Filter System Division
Process Filter Division
Fuel Filtration Division
580 West Park Road
Leetsdale, PA 15056
+1.724.318.1100

HYDAC TECHNOLOGY CORPORATION
Hydraulic Division –
Compact Hydraulics
450 / 445 Windy Point Drive
Glendale Heights, IL 60139
+1.630.545.0800

HYDAC TECHNOLOGY CORPORATION
Hydraulic Division – Tech Center
430 Windy Point Drive
Glendale Heights, IL 60139
+1.630.545.0800

HYDAC TECHNOLOGY CORPORATION
Cooling System Division
1051 Airlie Parkway
Denver, NC 28037
+1.610.266.0100

HYDAC TECHNOLOGY CORPORATION
Mobile Hydraulic Division
1660 Enterprise Parkway • Suite E
Wooster, OH 44691
+1.610.266.0100

HYDAC CYLINDERS LLC
540 Carson Road North
Birmingham, AL 35217
+1.205.520.1220

HYDAC TECHNOLOGY CORPORATION
HYDAC CORPORATION
Sales Office & Operations
1718 Fry Road • Suite 100
Houston, TX 77084
+1.281.579.8100

HYDAC TECHNOLOGY CORPORATION
HYDAC CORPORATION
NW Sales Office & Operations
1201 NE 144th St. Bldg. B • Suite 111
Vancouver, WA 98685
+1.610.266.0100

HYDAC TECHNOLOGY CORPORATION
HYDAC CORPORATION
NE Sales Office
1660 Enterprise Parkway • Suite E
Wooster, OH 44691
+1.610.266.0100

HYDAC TECHNOLOGY CORPORATION
HYDAC CORPORATION
SE Sales Office
1051 Airlie Parkway
Denver, NC 28037
+1.610.266.0100

HYDAC TECHNOLOGY CORPORATION
HYDAC CORPORATION
NC Sales Office
9415 West Forest Home Ave. • Suite 200
Hales Corners, WI 53130
+1.610.266.0100

Canada

www.HYDAC-NA.com

HYDAC CORPORATION
14 Federal Road
Welland, Ontario, Canada L3B 3P2
+1.905.714.9322

HYDAC CORPORATION
Sales Office
5160 75 Street NW
Edmonton, Alberta, Canada T6E 6W2
+1.780.484.4228

HYDAC CORPORATION
Sales Office
Montreal, Québec, Canada J2M 1K9
+1.877.539.3388

Mexico

www.HYDACmex.com

HYDAC INTERNATIONAL SA de CV
Calle Alfredo A Nobel No 35
Col Puente de Vigas
Tlalnepantla, Edo Mexico
CP 54090
Mexico
+011.52.55.4777.1262